

BEGE MIG[®] Encoders



MADE IN
EU

INNOVEREN. OPTIMALISEREN. VERBINDEN.



BEGE MIG. De kwaliteitsencoder die altijd past.

INNOVATE. OPTIMIZE. CONNECT.



BEGE MIG. The quality encoder that always fits.



WANNEER PRECISIE TELT

-  Hoogwaardige Engineering
-  IEC/NEMA Standaard Afmeting
-  Ruimtebesparend Ontwerp

WHEN PRECISION COUNTS

-  High Quality Engineering
-  IEC/NEMA Standard Size
-  Space-Saving Design

Technical data subject to modification
Copyright BEGE, whose property this document remains. No part thereof may be disclosed, copied, duplicated or in any other way made use of except with the written approval of BEGE.

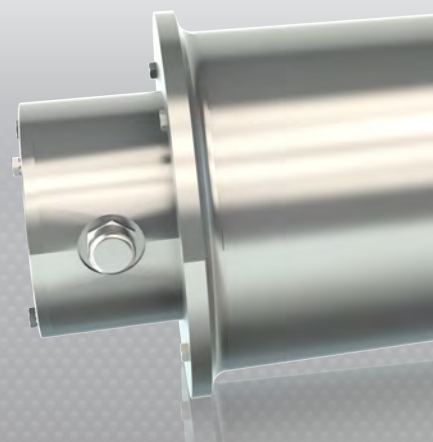

INHOUD

ALGEMENE INFORMATIE

Over de MIG encoder	4
MIG encoder types	5
Geïntegreerde aandrijfoplossingen	6
Branches	6

MIG BASIC INCREMENTELE ENCODERS

Technische gegevens MIG BASIC	8
Aansluitingsconfiguratie & signalen MIG BASIC	9

MIG NOVA+ INCREMENTELE ENCODERS

Technische gegevens MIG NOVA+	10
Aansluitingsconfiguratie & signalen MIG NOVA+	11

MIG AST ABSOLUUT ENCODERS

Technische gegevens MIG AST	12
Aansluitingsconfiguratie & signalen MIG AST	13

MAATVOERING & INSTALLATIE

Maatvoering	14
Tekening & flens uitvoering	15
De MIG installeren	16
Bestelvoorbeeld MIG	16

CONTENTS

GENERAL INFORMATION

About the MIG encoder	4
MIG encoder types	5
Integrated drive solutions	6
Branches	6

MIG BASIC INCREMENTAL ENCODERS

Technical data MIG BASIC	8
Terminals & signals MIG BASIC	9

MIG NOVA+ INCREMENTAL ENCODERS

Technical data MIG NOVA+	10
Terminals & signals MIG NOVA+	11

MIG AST ABSOLUTE ENCODERS

Technical data MIG AST	12
Terminals & signals MIG AST	13

DIMENSIONS & INSTALLATION

Dimensions	14
Drawing & flange design	15
Installing the MIG	16
Ordering example MIG	16

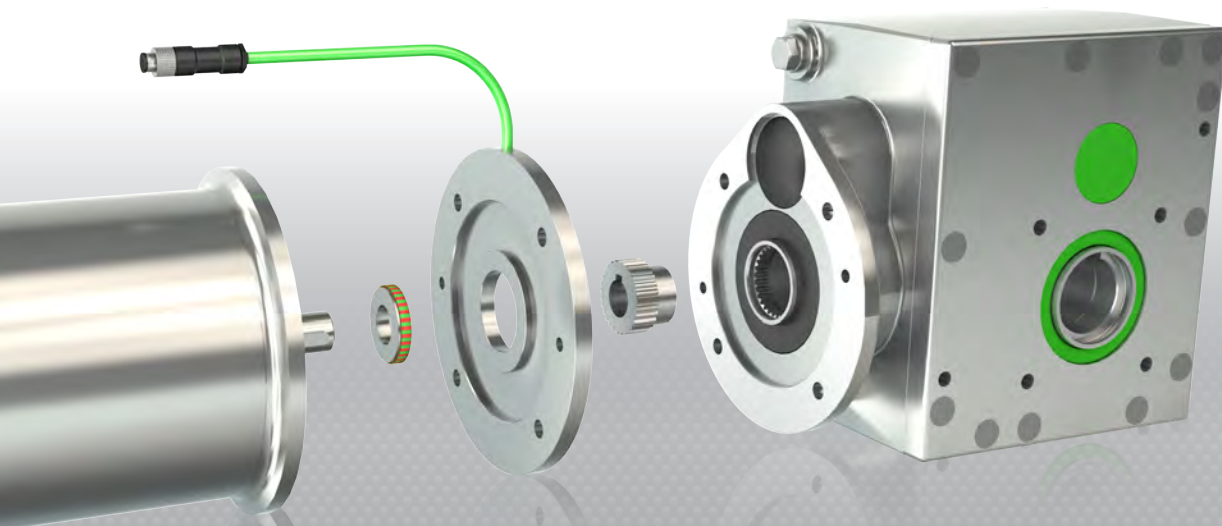

ALGEMENE INFORMATIE GENERAL INFORMATION

De ideale encoder is hier.
Ruimtebesparend, ultra
hygiënisch en uiterst hoge
signaalkwaliteit.

The ideal encoder is here.
Space saving, ultra hygienic
and high quality signal.

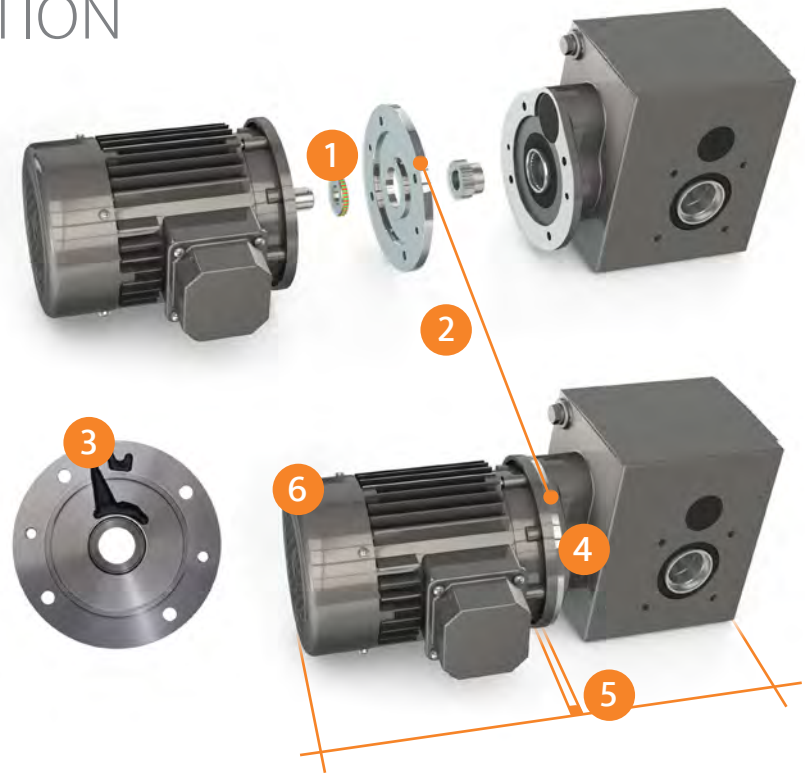

1. Robuust en schokbestendig

Dankzij het gebruik van een ge vulkaniseerde kunststof magneet is de encoder robuust en schokbestendig.

2. Eenvoudige montage

Past op iedere IEC elektromotor. Bij aangepaste aandrijvingen maken wij de BEGE MIG encoder op maat om te voldoen aan uw specifieke behoeftes.

3. Zeer stabiele contactloze signaalmeting

Met epoxyhars ingegoten hoogwaardige elektronica is de BEGE MIG volledig beschermd tegen externe invloeden. Hierdoor kan een zeer stabiele contactloze signaalmeting worden gegarandeerd.

4. Uitzonderlijke bescherming

Door de montage tussen motor en tandwielkast is onze encoder volledig beschermd tegen vuil, stof, corrosie en vloeistoffen. Zelfs tijdens hogedrukreiniging.

5. Zeer compact

Machines en aandrijvingen die de BEGE MIG gebruiken worden nauwelijks langer. De encoder wordt gemonteerd tussen de motor en tandwielkast en voegt 7 tot max. 15 mm toe aan de totale lengte.

6. Geen extra aandrijf aanpassingen

Omdat de BEGE MIG is geïntegreerd tussen de motor en de tandwielkast, zijn er geen motoraanpassingen zoals een verlengde ventilator kap of NDE-as vereist.

1. Robust and shockproof

The use of a vulcanised magnet ring makes the encoder sturdy and shockproof.

2. Easy installation

Fits on every IEC electric motor. For custom drives the BEGE MIG can be tailored to meet your specific needs.

3. Very stable contactless signal measurement

Epoxy resin sealed high quality electronics are completely protected from external influences which ensures a very stable contactless signal measurement.

4. Exceptional protection

Due to the assembly between motor and gear unit, our encoder is completely protected from dirt, dust, corrosion and liquids. Even during high pressure cleaning.

5. Incredibly compact

Machines and drive systems using the BEGE MIG barely increase in length. The encoder adds 7 to max. 15 mm to the total length.

6. No additional drive adjustments

Because the BEGE MIG is integrated between the motor and gear unit there are no motor modifications required e.g. extended fan cover or NDE shaft.

BEGE MIG® BASIC



A90°B
1 – 64 impulsen
NPN, PNP
HTL (Push-Pull)

De MIG Basic incrementele encoder maakt zeer nauwkeurige positioneringstaken eenvoudig uitvoerbaar en is geschikt voor regelingen met HTL-protocol. De MIG Basic is een economische oplossing voor simpele positioneringstaken met een A90°B uitgangssignaal en een resolutie tussen 1 – 64 pulsen per omwenteling.

The MIG BASIC incremental encoder makes highly accurate positioning tasks easy to perform and is suitable for control with HTL protocol. The MIG Basic is an economic solution for simple positioning tasks with an A90°B output signal and a resolution between 1 – 64 pulses per rotation.

BEGE MIG® NOVA+



A90°B / $\bar{A}90^{\circ}\bar{B}$
1 – 2048 impulsen
NPN, PNP, RS422
HTL (Push-Pull), TTL

De MIG NOVA+ incrementele encoder maakt zeer nauwkeurige positioneringstaken eenvoudig uitvoerbaar en is compatibel met nagenoeg alle regelingen (HTL en TTL). De MIG NOVA+ heeft een buitengewone resolutie met een A90°B / $\bar{A}90^{\circ}\bar{B}$ uitgangssignaal met maximaal 2048 impulsen per omwenteling.

The MIG NOVA+ incremental encoder makes highly accurate positioning tasks easy to perform and is compatible with virtually all controls (HTL and TTL). The MIG NOVA+ has an extraordinary resolution with an A90°B / $\bar{A}90^{\circ}\bar{B}$ output signal with up to 2048 impulses per rotation.

BEGE MIG® AST



4 – 18 bit
RS422 ($\pm 5V$)
SSI/BISS

De MIG absoluut single-turn encoder zorgt voor optimale interactie tussen de afzonderlijke systeemcomponenten en maakt zeer nauwkeurige positioneringstaken eenvoudig uitvoerbaar. Onze klanten installeren de MIG AST encoder in omgevingen waar veiligheid en nauwkeurigheid belangrijke factoren zijn.

The MIG absolute single-turn encoder ensures optimum interaction between the individual system components and makes highly accurate positioning tasks easy to perform. Our customers often install the MIG AST encoder interface in environments where safety and accuracy are key factors.

Incrementeel vs absoluut

Ten opzichte van de incrementele encoder heeft de absoluut single-turn uitvoering het voordeel dat deze de positie van de as gedurende één omwenteling onthoudt. Dankzij het geheugen weet deze encoder direct de juiste positie zodra de machine opnieuw wordt ingeschakeld, bijvoorbeeld na een stroomstoring.

Incremental vs absolute

Compared to the incremental encoder, the absolute single-turn version has the advantage of remembering the position of the shaft for one revolution. Thanks to its memory, this encoder knows the correct position immediately when the machine is switched on again, for example after a loss of power supply.

BEGE'S GEÏNTEGREERDE AANDRIJFOPLOSSINGEN · BEGE'S INTEGRATED DRIVE SOLUTIONS



Levensmiddelen- &
drankindustrie
Food & Beverage



Land- & tuinbouw
Agri- & Horticulture



Verpakkingen &
logistiek
Packaging &
Logistics



Bulk & stortgoed
Bulk & Solids

Voor machinebouwers is het een voortdurende uitdaging om met aandrijfcomponenten een rendabele installatie te realiseren. Individuele aandrijfcomponenten van meerdere leveranciers combineren, leidt vaak tot hoofdpijn en andere ongunstige effecten zoals tijdverspilling op het gebied van contract onderhandelingen, management en procesuitvoering.

BEGE biedt complete aandrijfsystemen waarvan de componenten naadloos op elkaar aansluiten. En omdat er slechts met één partner contact is, blijft alles overzichtelijk. Geen afleiding door verschillende contactpersonen, afwijkende levertijden, transportopties of betaalvoorwaarden en juist wel profijt van een solide partnerschap.

“Het draait niet om wat we maken, maar om wat we mogelijk maken.”

Gerard Paulides, directeur BEGE Aandrijftechniek

For manufacturers of machinery, the realization of a profitable installation using drive components is a constant challenge. Combining individual components from different suppliers often causes headaches and other undesirable effects such as wasted time due to contract negotiations, management and process execution.

BEGE provides complete drive systems with components that interact seamlessly, and as you're only working with a single partner, staying organized is no problem. You're no longer distracted by multiple agents, different delivery times, transportation options or payment terms, and you also reap the benefits of a solid partnership.

“It's not about what we make. It's about what we make possible.”



Marine & offshore

Marine & Offshore



Chemisch & farmaceutisch

Chemical & Pharmaceutical



Veehouderij & fokkerij

Livestock & Breeding



Bouw & constructie

Building & Construction

MIG BASIC INCREMENTELE ENCODERS

MIG BASIC INCREMENTAL ENCODERS



ELEKTRISCHE & MECHANISCHE WAARDEN · ELECTRICAL & MECHANICAL VALUES

Voeding U_B	Connecting voltage U_B	5 – 24 VDC
Max. pulsfrequentie	Max. impulse frequency	≤ 100 kHz
Max. toerental	Max. speed	6000 min ⁻¹
Uitgangssignalen	Output signals	A90°B
Pulsen per omwenteling	Impulses per rotation	1 – 64
Signaalniveau	Signal level	$U_{high} \geq U_B - 0.7V @ I_{last} \leq 10$ mA $U_{low} \leq 0.7V @ I_{last} \leq 10$ mA
Belastbaarheid van de uitgangen	Output capacities	≤ 30 mA @ $U_B = 5$ VDC ≤ 20 mA @ $U_B = 24$ VDC
Uitgangscircuit	Interface	HTL (Push-Pull)
Externe uitlezing	External evaluation	NPN, PNP
Beveiligd tegen ompolen	Reverse polarity protection	✓
Kortsluitvast aan de uitgang	Short circuit protection at the output	✓
Motorasspeling	Motor shaft tolerance	0.5 mm axiaal 0.05 mm radiaal
Temperatuurbereik	Temperature range	-30 °C — +80 °C
Flens- & naafmateriaal	Flange & hub material	Aluminium
Aansluitkabel	Connection cable	PUR-mantel 4x0.14 mm ² afgeschermd PUR-sheath 4x0.14 mm ² screened
Kabellengte	Cable length	Standaard 2 m. *
Max. kabellengte	Max. cable length	Max. 20 m. @ 24 VDC
Beschermingsklasse	Protection class	IP55, IP67 **
Certificaten	Certificates	CE, RoHs
Flens uitvoering	Flange design	IEC, NEMA, Deksel, 4-pins IEC, NEMA, Cover, 4-pin plug
Optioneel	Optional	Geschikt voor hydromotor, verhoogd temperatuur bereik, afwijkende rotorboring, speciale flens Suitable for hydromotor, increased temperature range, deviating rotor bore, customized flange

* Afwijkende lengtes op aanvraag

** IP67 afhankelijk van de afdichting tussen de motor- en machineflens

* Different lengths on request

** IP67 depending on the sealant used between motor and machine flange

AANSLUITING · TERMINALS

Aansluiting · Terminal	U_B	0 V	A	B
Kabel · Cable	bruin brown	wit white	geel yellow	groen green

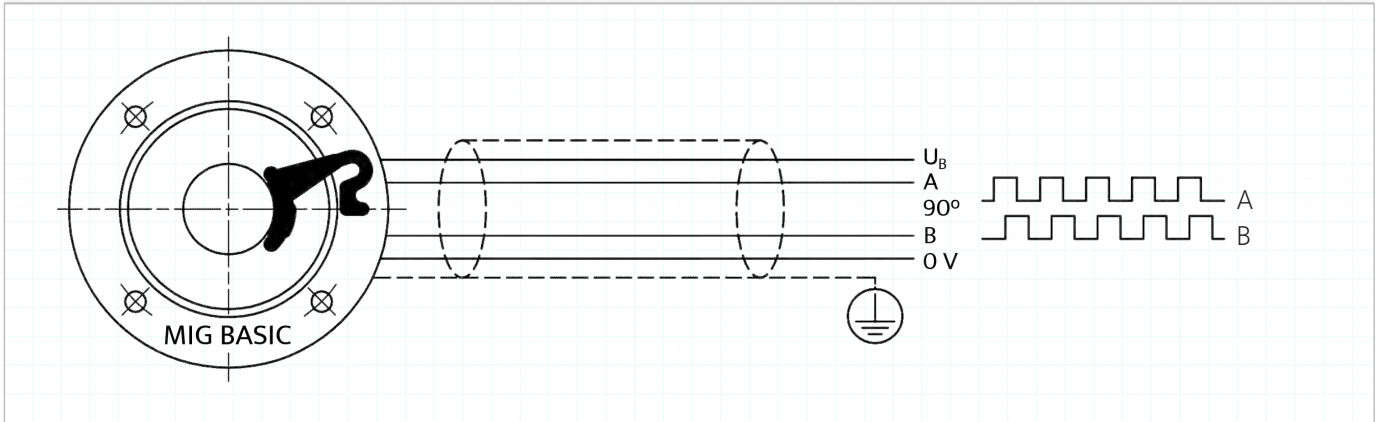

Opgelet: Onnodige aansluitdraden isoleren en beschermen tegen kortsluiting.

Attention: Please isolate unused connection wires and protect them from short-circuits.

SIGNAAL EVALUATIE · SIGNAL EVALUATION

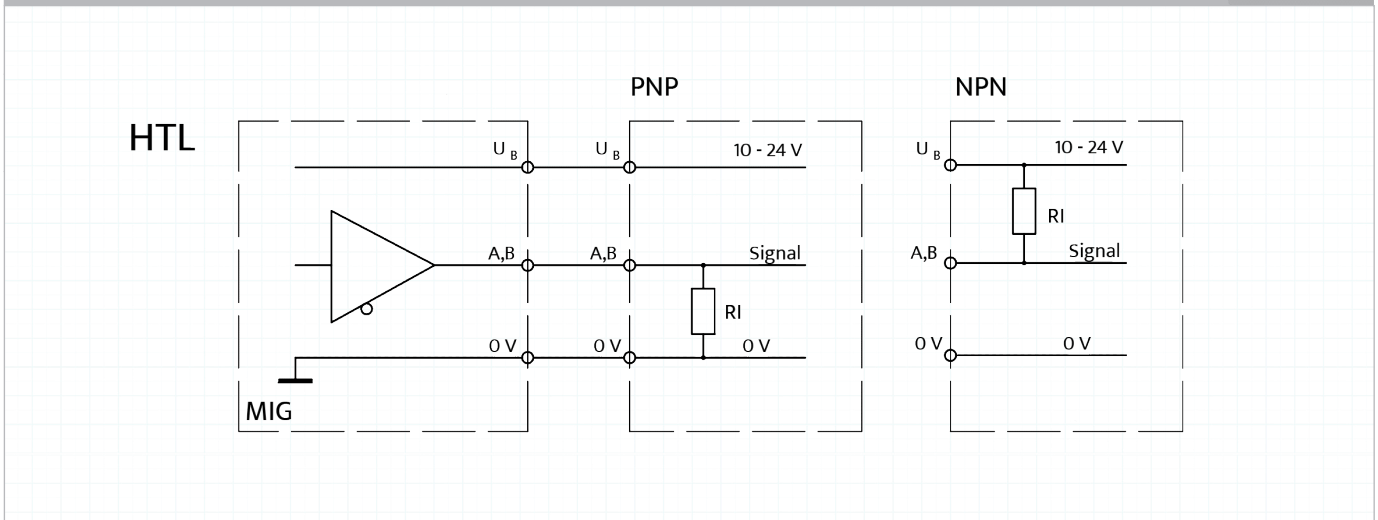

MIG NOVA+ INCREMENTELE ENCODERS

MIG NOVA+ INCREMENTAL ENCODERS



ELEKTRISCHE & MECHANISCHE WAARDEN · ELECTRICAL & MECHANICAL VALUES

Voeding U_B	Connecting voltage U_B	5 – 24 VDC
Max. pulsrequentie	Max. impulse frequency	≤ 100 kHz
Max. toerental	Max. speed	6000 min ⁻¹ (1024 impulses) 3000 min ⁻¹ (2048 impulses)
Uitgangssignalen	Output signals	A90°B / $\bar{A}90^\circ\bar{B}$
Pulsen per omwenteling	Impulses per rotation	1 – 2048
Signaalniveau	Signal level	$U_{high} \geq U_B - 0.7V @ I_{last} \leq 10$ mA $U_{low} \leq 0.7V @ I_{last} \leq 10$ mA
Belastbaarheid van de uitgangen	Output capacities	≤ 30 mA @ $U_B = 5$ VDC ≤ 20 mA @ $U_B = 24$ VDC
Uitgangscircuit	Interface	HTL (Push-Pull), TTL
Externe uitlezing	External evaluation	NPN, PNP, RS422
Beveiligd tegen ompolen	Reverse polarity protection	✓
Kortsluitvast aan de uitgang	Short circuit protection at the output	✓
Motorasspeling	Motor shaft tolerance	0.5 mm axiaal 0.05 mm radiaal
Temperatuurbereik	Temperature range	-30°C — +80°C
Flens- & naafmateriaal	Flange & hub material	Aluminium, Roestvast staal · Aluminium, Stainless steel
Aansluitkabel	Connection cable	PUR-mantel 6x0.14 mm ² afgeschermd PUR-sheath 6x0.14 mm ² screened
Kabellengte	Cable length	Standaard 2 m. *
Max. kabellengte	Max. cable length	Max. 100 m. @ 5 VDC Max. 20 m. @ 24 VDC Max. 50 m. @ 24 VDC, $f_{max} = 50$ kHz
Beschermingsklasse	Protection class	IP55, IP67 **
Certificaten	Certificates	CE, RoHS
Flens uitvoering	Flange design	IEC, NEMA, Deksel, 4-pins (niet voor TTL) IEC, NEMA, Cover, 4-pin plug (not for TTL)
Optioneel	Optional	Geschikt voor hydromotor, verhoogd temperatuur bereik, afwijkende rotorboring, speciale flens Suitable for hydromotor, increased temperature range, deviating rotor bore, customized flange

* Afwijkende lengtes op aanvraag

** IP67 afhankelijk van de afdichting tussen de motor- en machineflens

* Different lengths on request

** IP67 depending on the sealant used between motor and machine flange

MIG NOVA+ AANSLUITING · TERMINALS

Aansluiting · Terminal	U_B	0 V	A	B	\bar{A}	\bar{B}
Kabel · Cable	bruin brown	wit white	geel yellow	groen green	roze pink	grijs grey

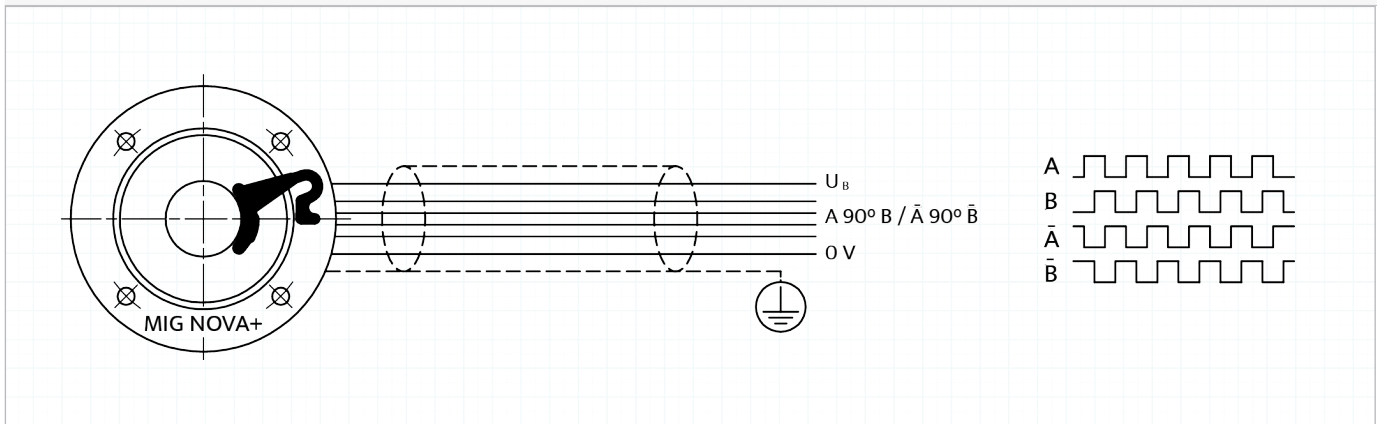

Opgelet: Onnodige aansluitdraden isoleren en beschermen tegen kortsluiting.

Attention: Please isolate unused connection wires and protect them from short-circuits.

SIGNAAL EVALUATIE · SIGNAL EVALUATION

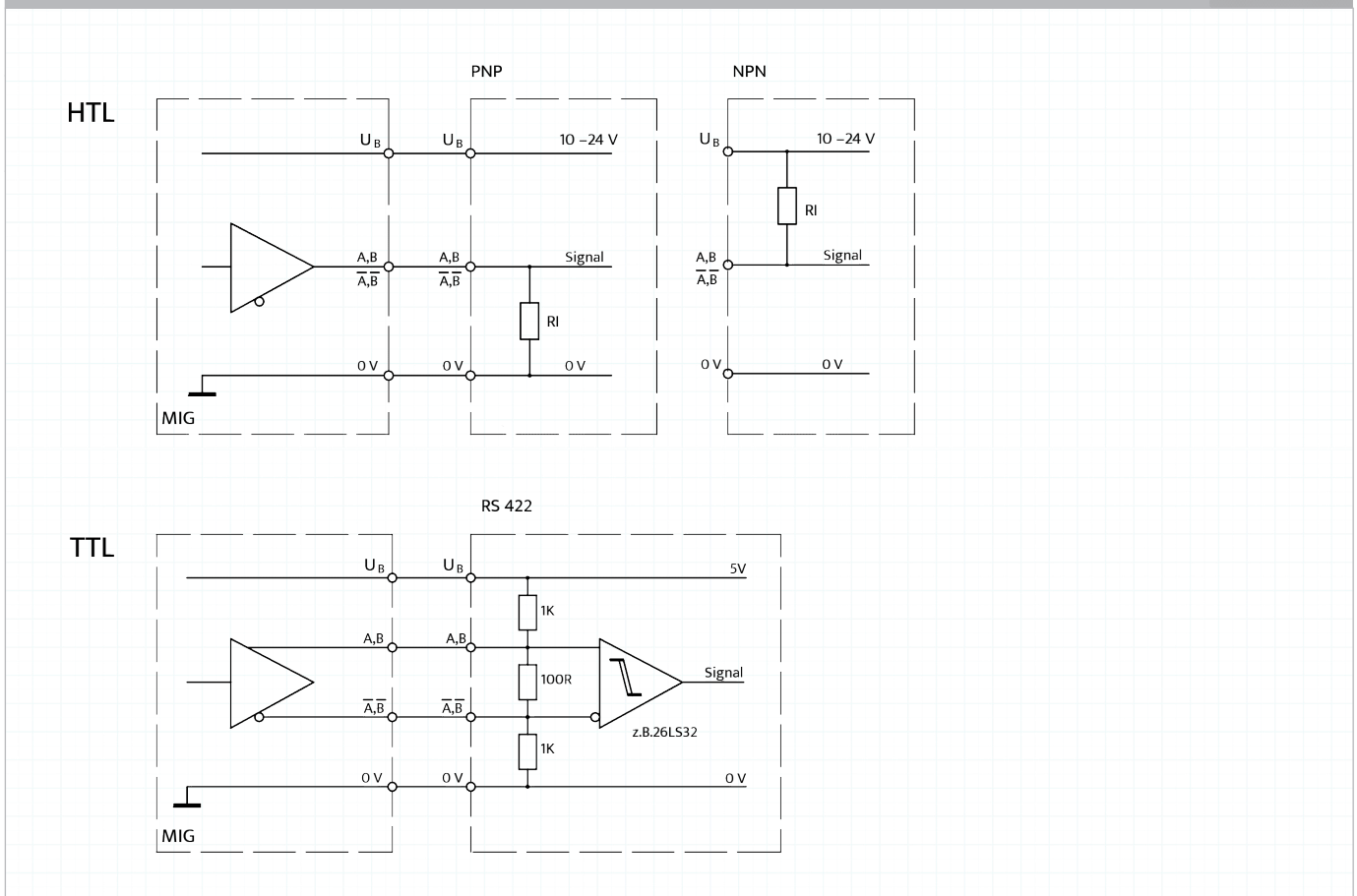

MIG AST ABSOLUUT SINGLE-TURN ENCODERS

MIG AST ABSOLUTE SINGLE-TURN ENCODERS

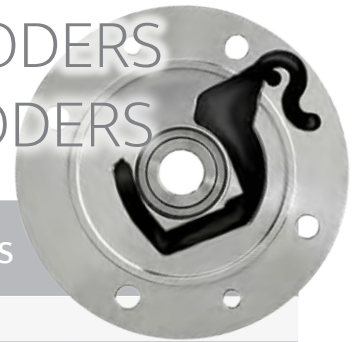

ELEKTRISCHE & MECHANISCHE WAARDEN · ELECTRICAL & MECHANICAL VALUES

Voeding U_B	Connecting voltage U_B	5 – 24 VDC
Max. toerental	Max. speed	6000 min ⁻¹
Belastbaarheid van de uitgangen	Output capacities	≤ 200 mA @ $U_B = 5$ VDC ≤ 30 mA @ $U_B = 24$ VDC
Uitgangscircuit	Interface	SSI, BiSS
Externe uitlezing	External evaluation	RS422 (± 5V) @ 30 mA
Beveiligd tegen ompolen	Reverse polarity protection	✓
Kortsluitvast aan de uitgang	Short circuit protection at the output	✓
Meetbereik	Measuring range	360°
Resolutie	Resolution	4 – 18 bit
Lineariteit (25 °C)	Linearity (25 °C)	< 0.35° *
Herhaal nauwkeurigheid	Repeat accuracy	≤ 0,1°
Monoflop-tijd	Monoflop time	20 μs
SSI-kloksnelheid/code	SSI clock rate/Code	100 kHz – 4 MHz/binary · binary
BiSS-kloksnelheid/code	BiSS clock rate/Code	100 kHz – 5 MHz/binary · binary
Vernieuwingsfrequentie van gegevens	Data refresh rate	30 μs
Toegestane belasting/kanaal	Permissable load/channel	120 Ω
Foutbit	Error bit	✓
Waarschuwingbit	Warning bit	✓
CRC polynoom	CRC Polynom	0x43
Motorasspeling	Motor shaft tolerance	0.2 mm axiaal 0.05 mm radiaal
Temperatuurbereik	Temperature range	-30 °C — +80 °C
Flens- & naafmateriaal	Flange & hub material	Aluminium, RVS · Aluminium, Stainless steel
Aansluitkabel	Connection cable	PUR-mantel 7x0.14 mm ² afgeschermd PUR-sheath 7x0.14 mm ² screened
Kabellengte	Cable length	Standaard 2 m. **
Beschermingsklasse	Protection class	IP55, IP67 ***
Certificaten	Certificates	CE, RoHS
Flens uitvoering	Flange design	IEC, NEMA, Deksel · IEC, NEMA, Cover
Optioneel	Optional	Geschikt voor hydromotor, verhoogd temperatuur bereik, afwijkende rotorboring, speciale flens Suitable for hydromotor, increased temperature range, deviating rotor bore, customized flange

* Afhankelijk van de magneetdiameter

** Afwijkende lengtes op aanvraag

*** IP67 afhankelijk van de afdichting tussen de motor- en machineflens

* Depending on the magnet diameter

** Different lengths on request

*** IP67 depending on the sealant used between motor and machine flange

MIG AST AANSLUITING · TERMINALS

Aansluiting · Terminal	U_B	0 V	C+	C-	D+	D-	Error
Kabel · Cable	bruin brown	wit white	groen green	geel yellow	grijs grey	roze pink	rood red

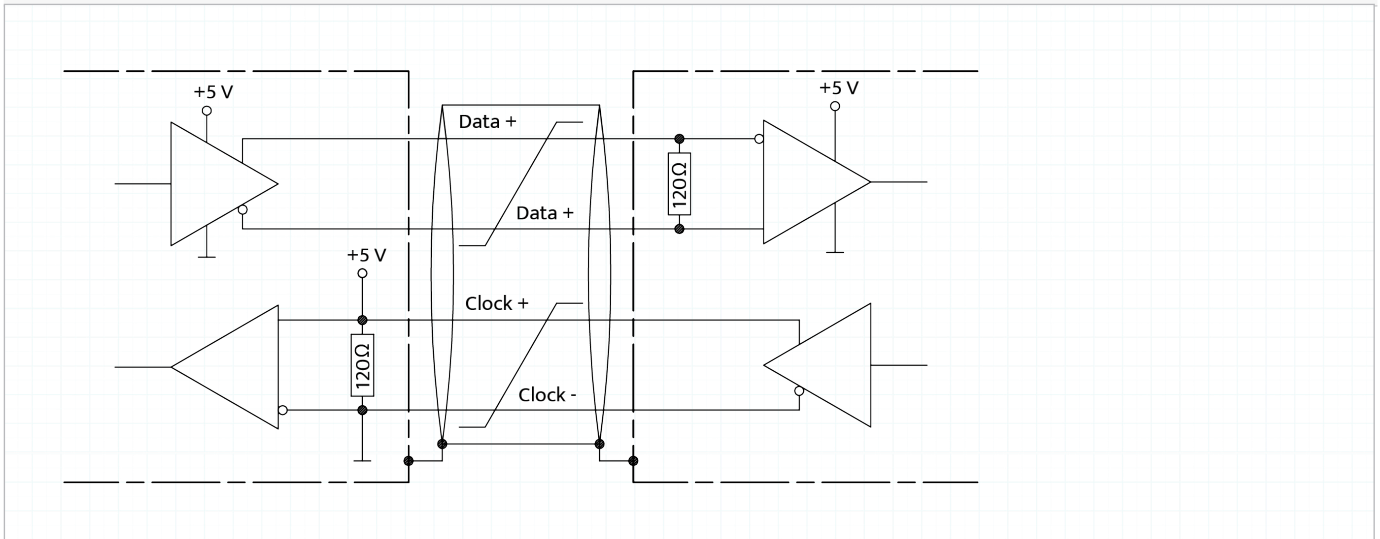

Opgelet: Onnodige aansluitdraden isoleren en beschermen tegen kortsluiting.

Attention: Please isolate unused connection wires and protect them from short-circuits.

SIGNAAL EVALUATIES · SIGNAL EVALUATION

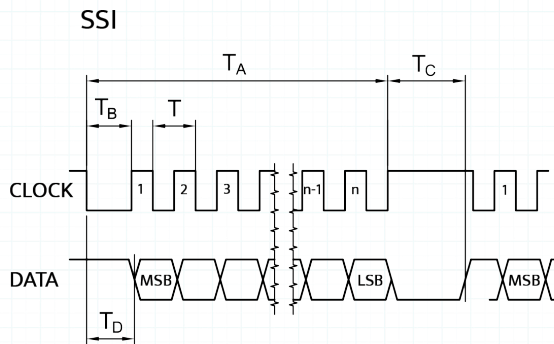

Gebruiksaanwijzing/De MIG AST kalibreren:

De kalibratiemodule is vereist bij het installeren van de MIG AST. Raadpleeg onze gebruiksaanwijzing voor meer informatie over het kalibreren van de MIG AST.

Operating instructions/Calibrating the MIG AST:

The calibration module is required when installing the MIG AST. For more information on how to calibrate the MIG AST please refer to our operating instructions.

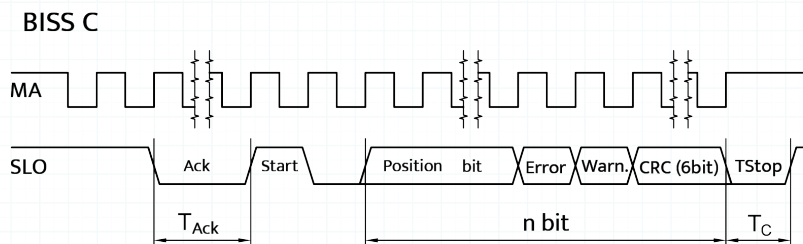

MAATVOERING & INSTALLATIE

DIMENSIONS & INSTALLATION

MAATVOERING · DIMENSIONS									BOUWGROOTTES IEC · FRAME SIZES IEC													
Øa	Øb	c	Ødi	Øe	f1	f2	k	s	BG	Fl.	Ød x l	ta	BASIC ØDa	N+ ØDa	AST ØDa							
80	50	7	44	65	2,5	3	7	5,8	56	FT 65	Ø 9 x 20	2	43	43	n/a							
90	60	7	54	75	2,5	3	7	5,8	63	FT 75	Ø11 x 23	2	43	43	53							
105	70	7	64	85	2,5	3	7	7	56	FT 85	Ø 9 x 20	2	60	60	55							
									71	FT 85	Ø14 x 30	2	60	60	55							
120	80	7	74	100	3	3,5	7	7	56	FF 100	Ø 9 x 20	2	60	60	55							
									63	FT 100	Ø11 x 23	2	60	60	55							
									80	FT 100	Ø19 x 40	2	60	60	55							
140	95	7	85	115	3,5	4	7	9	63	FF 115	Ø11 x 23	2	60	60	55							
									71	FT 115	Ø14 x 30	2	60	60	55							
160	110	9	85	115	3,5	4	9	9	90	FT 115	Ø24 x 50	2	60	60	n/a							
									7	100	130	3,5	4	7	9	71	FF 130	Ø14 x 30	2	60	60	55
									80	FT 130	Ø19 x 40	2	60	60	55							
200	130	9	100	130	3,5	4	9	9	90	FT 130	Ø24 x 50	2	60	60	n/a							
									100	FT 130	Ø28 x 60	2	60	60	n/a							
									112	FT 130	Ø28 x 60	2	60	60	n/a							
									80	FF 165	Ø19 x 40	2	60	60	n/a							
250	180	12	170	215	4	5	12	3,5	90	FF 165	Ø24 x 50	2	60	60	n/a							
									100	FT 165	Ø28 x 60	2	60	60	n/a							
									112	FT 165	Ø28 x 60	2	60	60	n/a							
300	230	12	218	265	4	5	12	3,5	132	FT 165	Ø38 x 80	3	n/a	105	n/a							
									100	FF 215	Ø28 x 60	2	n/a	60	n/a							
350	250	12	238	300	5	6	12	17	112	FF 215	Ø28 x 60	2	n/a	60	n/a							
									132	FT 215	Ø38 x 80	3	n/a	105	n/a							
400	300	15	290	350	5	6	15	17,5	132	FF 265	Ø38 x 80	3	n/a	105	n/a							
450	350	15	340	400	5	6	15	17,5	160	FF 300	Ø42 x 110	3	n/a	105	n/a							
									180	FF 300	Ø48 x 110	3	n/a	105	n/a							
400	300	15	290	350	5	6	15	17,5	200	FF 350	Ø55 x 110	3	n/a	105	n/a							
450	350	15	340	400	5	6	15	17,5	225	FF 400	Ø55 x 110	3	n/a	105	n/a							
											Ø60 x 140											

Andere maten op aanvraag
Different dimensions on request

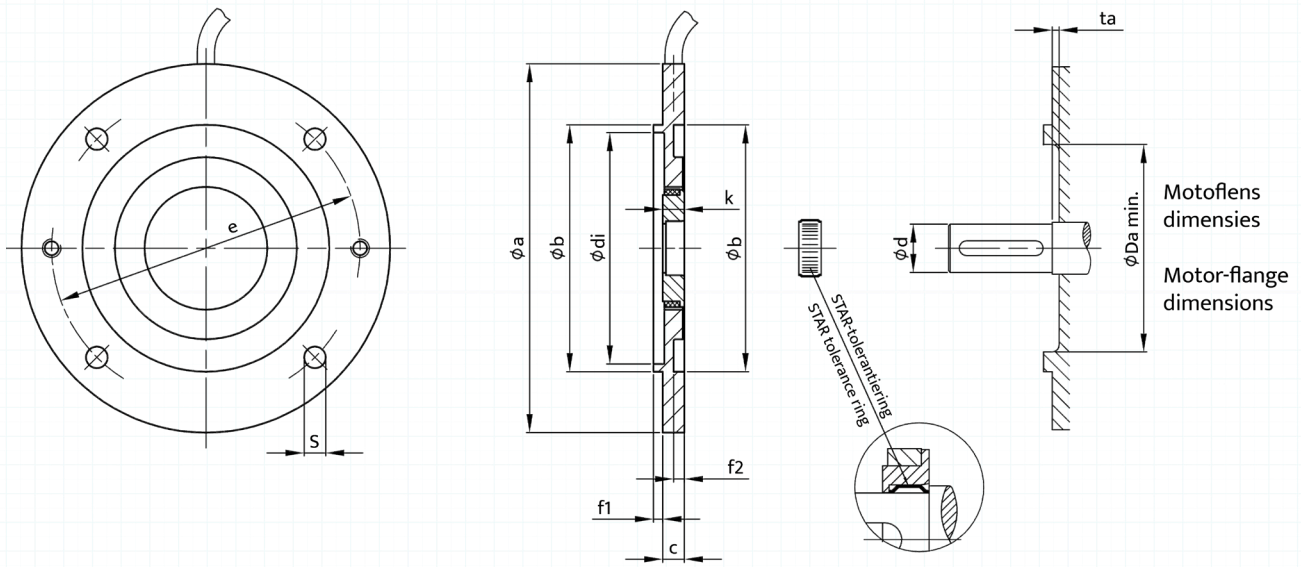

FLENS UITVOERING · FLANGE DESIGN

B5 & B14
IEC flensuitvoering [IEC]
IEC design [IEC]

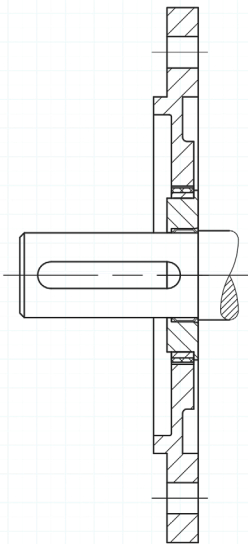

B3, B5 & B14
Deksel uitvoering [D]
Cover design [D]

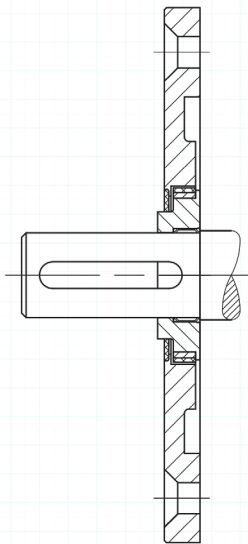

4-pins [S]
4 pin plug design [S]

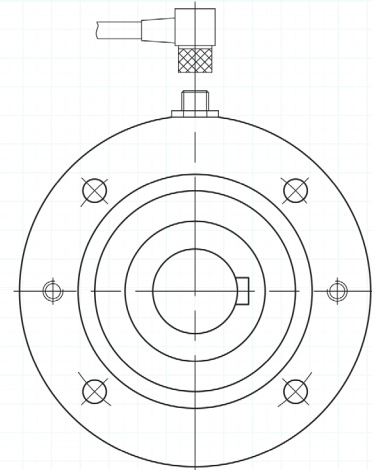

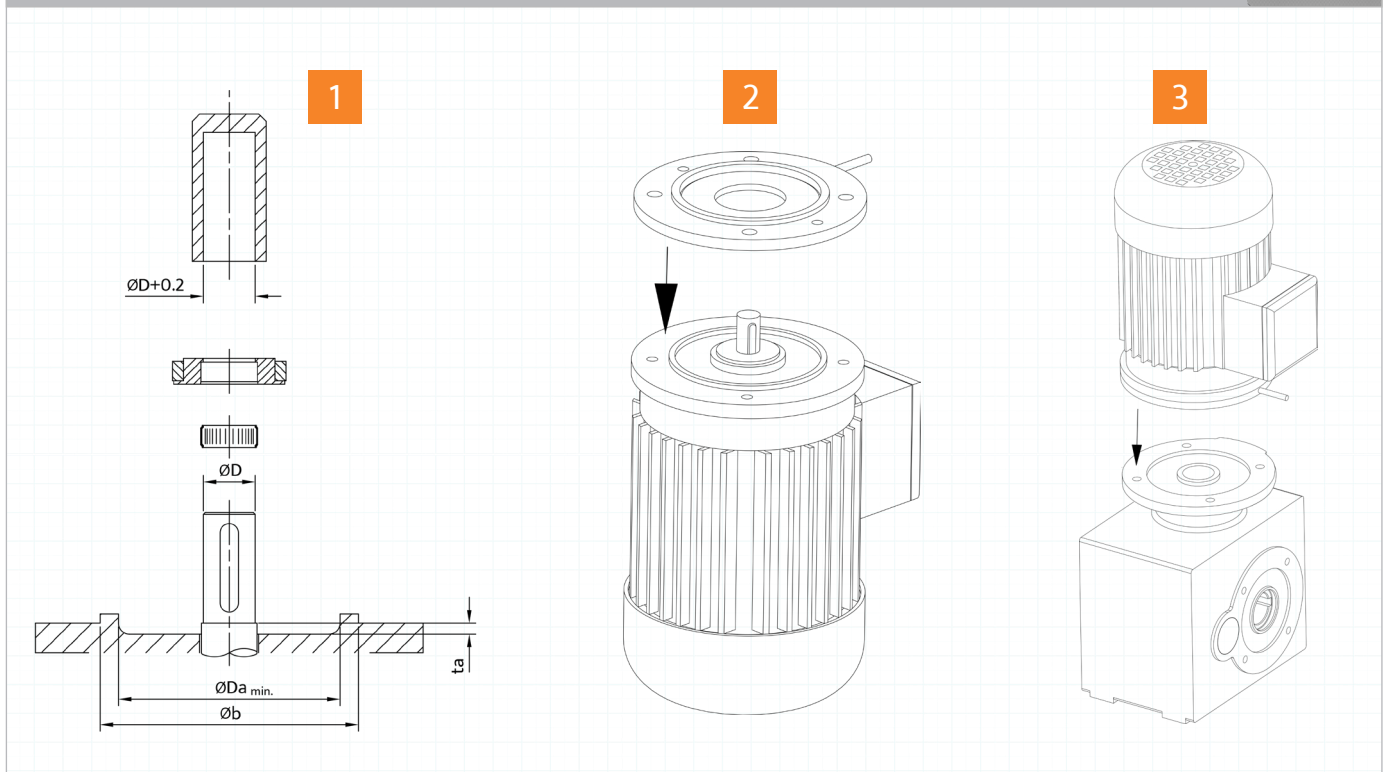

1. Controleer afmetingen en monteer magnetische ring
2. Monteer encoderflens op motor
3. Monteer motor op tandwielkast

Zie handleiding voor meer installatiedetails.

1. Check measures and mount magnetic ring
2. Mount encoder flange on motor
3. Mount motor on gear unit

See manual for more installation details

BESTELVOORBEELD MIG · ORDERING EXAMPLE MIG

MIG - N+ - 105 - 14 - 1024 | S · 18 - 7 - 2 - IEC - ALU

BASIC, NOVA+ of AST
BASIC, NOVA+ or AST

Flensdiameter
 Flange diameter

Rotorboring
 Rotor bore

Alleen voor NOVA+ en Basic
 # impulsen
 # impulses

Flens- & naafmateriaal
 Flange & hub material

Flens uitvoering
 Flange design

Kabellengte
 Cable length

Flensdikte
 Flange thickness

Alleen voor AST
 Uitgangscircuit · Resolutie
 Interface · Resolution

GEÏNTEGREERDE AANDRIJFOPLOSSINGEN

Alle merken. Alle typen. De universele encoder die altijd past.

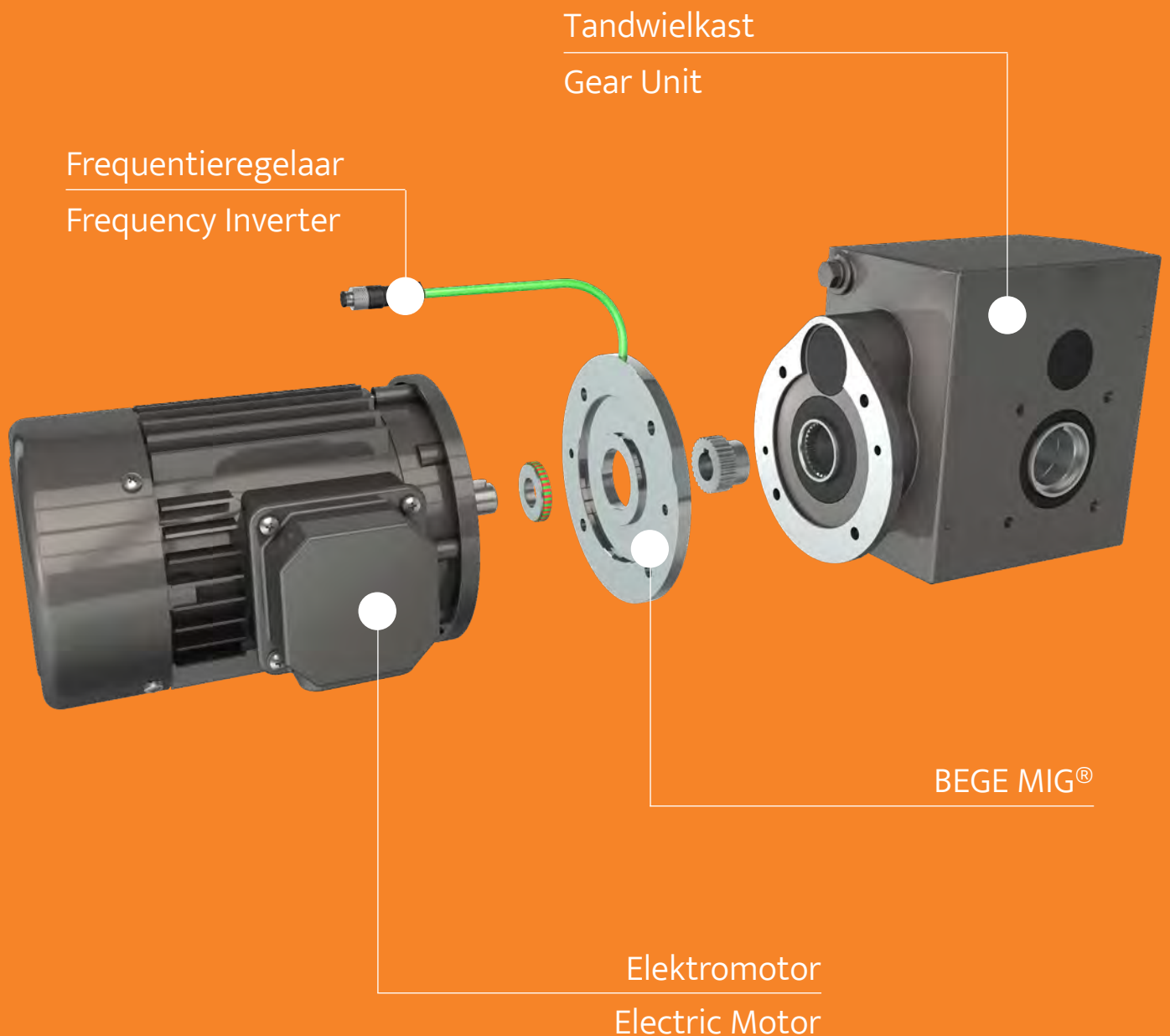

INTEGRATED DRIVE SOLUTIONS

All brands. All types. The universal encoder that always fits.

Motorreductoren · Gear Motors

RVS · Stainless Steel



GE Tandwiel Helical



KE Kegewiel Helical Bevel

Tandwiel · Helical



G Tandwiel Helical



M Mini Tandwiel Mini Helical

Kegewiel · Helical Bevel



K Kegewiel Helical Bevel



VLM Kegewiel Bevel

Motorvariatoeren · Variable speed



AM Tandwiel Helical



AM/M Kegewiel Helical Bevel

Hypoïde · Hypoid



BPM Hypoïde Hypoid

Wormwiel · Worm



SLM Wormwiel Worm

Trommel · Drum



TM Trommelmotor Drum motors

Tandwielkasten · Gear Units

RVS · Stainless Steel



HDV Haaks Bevel

Tandwiel · Helical



DSG Tandwiel Helical

Kegewiel · Helical Bevel



L Miniatuur Haaks Miniature Bevel



V Haaks Bevel



RXO-RXV Kegewiel Helical Bevel

Hypoïde · Hypoid



H Hypoïde Hypoid

Wormwiel · Worm



S Wormwiel Worm

Parallel



RXP Parallel

Planetair · Planetary



EX Planetair Planetary



EXB Planetair Haaks Planetary Bevel

Elektromotoren

RVS · Stainless Steel



KBS Premium

3-fase · 3-phase



H5AZ 3-fase IE3
H7AZ 3-phase IE3



SA 3-fase IE2 & IE3
SC 3-phase IE2 & IE3

ATEX



5AT 7AT ATEX

Tril · Vibration



VV Standard



VVE ATEX

Electric Motors



BES Economy



5AZC 1-fase
1-phase



Micro
VV Micro



WC CSA

Motion Control & Servo

MIG encoders



NOVA+ Incrementeel
Incremental



AST Absoluut Single Turn
Absolute Single Turn



BASIC Incrementeel
Incremental

Frequentieregelaars · Frequency Inverters



EFC 3610 Energiezuinig
Energy Efficient



EFC 5610 Hoog koppel
High torque



S100 Hoge Prestaties
High Performance



M100 Micro

HMI



XGT HMI Panel

Servo Motor



MS2N Synchron
Synchronous

Servo reductoren · Servo Gear Units



LC Mini Haaks
Mini Bevel



VC Kegewiel
Bevel



HC Hypoide
Hypoid



SC Wormwiel
Worm

Aandrijfcomponenten · Drive Components

Tandwielen & tandheugels · Gears & Racks



TH Tandheugels
Gear Racks



TW Rechte tandwielen
Spur Gears



CTW Conische tandwielen
Bevel Gears

Ketting & kettingwielen · Chains & Sprockets



RK Rollenketting
Roller Chain



HB Holleboutketting
Hollow Pin Chain



TRK Transportketting
Conveyor Chain



FLK Flyerketting
Leaf (Flyer) Chain



KW Kettingwielen
Sprockets



PL Plaatwielen
Platwheels



TBKW Klembus kettingwielen
Clamping Bush Sprockets



KSPW Kettingspanwielen
Idler Sprockets

Koppelingen & klemelementen · Couplings & Clamping



KK Kettingkoppelingen
Chain Couplings



T/C Slipkoppelingen
Torque Limiters



BEGE.SAMEN
BEDREVEN IN AANDRIJVEN



BEGE Aandrijftechniek

Anton Philipsweg 30
2171 KX Sassenheim
Nederland
+31 252-220 220
verkoop@bege.nl

WWW.BEGE.NL