

# OPERATOR'S MANUAL



## 2" DIAPHRAGM PUMP (BA50XX-XXXX-X)

PN 6461-11

Revised: 2020-8-7

Rev: K

### Model Description Chart

## BA50XX-XXXX-X

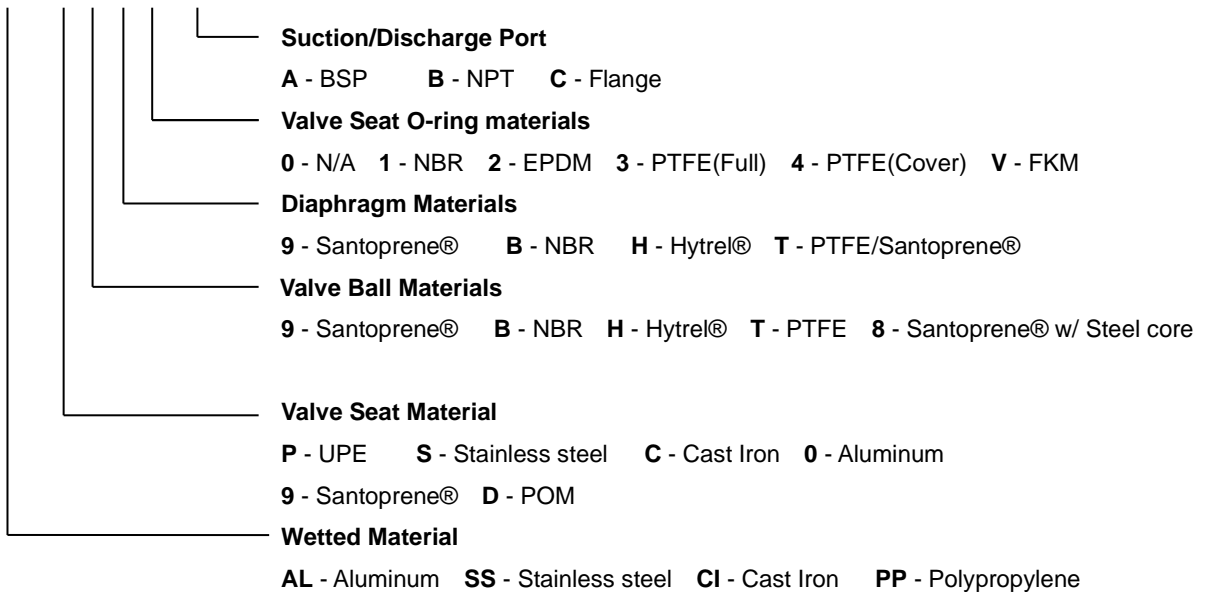

### Pump Data

Description	Data
Suction/Discharge Port Size	2"
Center body material	Aluminum
Max. air inlet pressure	8.3 bar (120 psi)
Max. flow rate	667 lpm (176 gpm)
Max. suction lift - dry	6.2 m (20 ft)
Displacement / cycle	3.78 L (1.0 gal)
Max. Particle size	7.0 mm (9/32")
Noise level @70psi	75 dB
<b>Weight</b>	
Aluminum	24.5 kgs (54 lbs)
Stainless steel	53 kgs (117 lbs)
Cast Iron	48.5 kgs (107 lbs)
Polypropylene	26 kgs (57 lbs)

### Maximum Temperature Limits

Material	Application temperature range
POM	-12°- 82°C (10°-180°F)
Santoprene®	-40°- 107.2°C (-40°- 225°F)
PTFE	4.4°- 104°C (40°- 220°F)
Nitrile	-12°- 82°C (10°- 180°F)
FKM	-40°-176°C (-40°- 350°F)
PVDF	-12°- 93°C (-20°-150°F)
Hytrel®	-28.9°- 65.5°C (10°-200°F)
Polypropylene	0 -79.4°C (32°- 175°F)
Nylon	-40°- 120°C (-40°- 248°F)
EPDM	-51°- 138°C (-60°-280°F)

BSK Fluid Technology LLC

Add: 3625 Aqua Spring Drive Plano, Tx75025 U.S.A

E-mail: sales@bskfluid.com

http://www.bskfluid.com

## SAFETY AND MAINTANANCE INFORMATION

### Operating and Safety Precautions

**Principal of operation** – The BSK pump is an air operated double diaphragm pump featuring an air motor and double liquid chamber as the primary components of its design. The air motor directs incoming air flow and pressure in alternating cycles behind the double diaphragms (i.e. one per liquid chamber) flexing them to the left and right in a reciprocating motion. The reciprocating motion produces alternating suction and discharge cycles where the liquid flow is positively displaced through the pump by the inlet and outlet check valves.

 **Please read, understand and follow the information below to avoid injury and property damage.**

#### **PUMP AIR SUPPLY**

- Do not exceed the maximum inlet air pressure as stated on the pump model plate.
- Ensure the pump air supply conforms to the pumps design requirement for both pressure and volume capacity for the pump air consumption requirement.
- The air supply line must be equipped with a filter-pressure regulator to control the air flow volume and ensure the pumps maximum air pressure rating is not exceeded – Note: best practice installation requires a 90 ° quarter turn isolation / shut-off valve be installed on the air supply line.
- Connecting a clean and dry compressed air supply to the pump ensures its maximum service life span.
- A flexible hose coupling must be used to connect a rigid air supply pipe line to the pump air intake to avoid the transfer of mechanical stress (i.e. pipe vibration or expansion) to the pump.
- Do not run the pump with excessive high air pressure and high air flow volume settings, this will run the pump at a high a stroke frequency and may cause the pump to cavitate and lead to premature wear of the pump components shortening the service life span.
- Do not run the pump dry for long periods of time this will lead to premature wear of the pump's components shortening its service life span.

 **Ensure the air supply is connected to the correct port on the pump.**

 **Do not run the pump with an overpressure setting above the pump design capacity this can damage the pump and / or property and cause severe injury.**

#### **AIR SERVICE AND LUBRICATION**

- Do not over lubricate the pump - the pump O-ring and Y-ring seals including all elastomer gaskets are lubricated during its manufacture and maintenance services. Excessive lubrication can negatively affect the pumps performance.
- If an air lubricator is installed ensure the oil lubricant used is chemically compatible with the pump seals and the lubrication flow rate is at the lowest possible setting.

#### **PUMP PROCESS CONNECTIONS - (Fluid Connections)**

- Connect the system suction and discharge piping to the pump inlet / outlet process connections using flexible couplings (i.e. hose or bellow coupling). Flexible couplings ensure no mechanical stress (i.e. pipe vibration or expansion) is transmitted to the pump process connections.

#### **Important Note:**

- Ensure the flexible couplings (i.e. hose or bellow coupling) conform to the pump's maximum discharge pressure.
- Ensure the material compatibility selection of the flexibly couplings (i.e. hose or bellow coupling) is compatible with the pumped process fluid.

- To reduce hydraulic surge pulsation (i.e. Water Hammer) resulting from the pump's positive displacement stroke action it is recommended that the discharge process pipeline be equipped with a pulsation dampener (i.e. surge vessel).

 **Important Note:**

- Select the dampener vessel size according to the pump stroke frequency and displacement capacity.
- Select the correct material compatibility for the dampener vessel bladder or diaphragm for the pumped process fluid.
- Ensure all components (i.e. piping, hoses, couplings, connectors...etc) for the pump suction and discharge process fluid circuits are rated for the pump's maximum delivery pressure.
- Prior to operating the pump inspect and confirm that there are no worn or damage to components on the pump suction and discharge fluid circuits (i.e. piping, hoses, couplings, connectors...etc) which may fail when the pumps maximum delivery pressure is applied to the system.

#### HAZARDOUS CONDITION SAFETY PRECAUTIONS

 **EXPLOSION HAZARD**

- Models containing aluminum wetted parts cannot be used with 1,1,1 trichloroethane, methylene chloride or other halogenated hydrocarbon solvents which may react and explode.

Important Note: (Pump Material Inspection)

Before using the pump to transfer any of the above stated solvent types first inspect the motor section, fluid caps, manifolds and all wetted parts to confirm and ensure the chemical compatibility of all the pump components for the process fluid.

-  **STATIC SPARK AND IGNITION SOURCE HAZARDS:** Avoid sparking and static discharge - they can cause explosions and fire leading to property damage and severe injury or death.

**Ground (earth) the pump station** - including the pump, mounting frames, structural supports, suction and discharge pipe manifolds, all pump system components and fittings.

**Explosion Proof Installation** - Ensure the complete installation complies with the applicable governing IEC standards and ATEX Zoning Specifications.

Important Note: the size of the earthing and bonding conductors and the earth loop resistance measurements must comply with the applicable national standards and regulations.

- Sparks can ignite flammable process fluids and vapors – all ignition source risks must be mitigated in accordance with the governing standards and regulations.
- Secure the pump and all process connections including the system components. Avoid loose connections, vibrations and friction points which may lead to hot surfaces, create sparks or build-up static energy.
- Install the pump in a well-ventilated area or use suitable area compliant ventilation equipment to extract explosive fumes and vapours.
- Remove flammable items from high temperature areas with heat sources, open flames and / or sparks.

 **PUMP EXHAUST:** Warning - air vented from the pump exhaust may contain hazardous materials

- Contaminants vented from the pump exhaust can cause severe injury and property damage. When installing a pump consider the risk posed in the event of a containment leak from the pump exhaust.
- In the event of a diaphragm failure hazardous process fluid can be forced out of the pump exhaust. Where a safety hazard exists (flammable or toxic process fluids) the pump exhaust outlet must be piped to a safe remote location or holding tank for release.

- Use a grounded flexible hose (min 10mm I.D.) to connect the pump exhaust outlet to the muffler, this will prevent the build-up of a static electric charge.
- To prevent “Icing Up” the pump exhaust by freezing the muffler and air motor spool valve ensure a dry compressed air supply is connected to the pump. Alternatively, a coalescing filter can be installed to separate excess moisture from the air supply.

 **HAZARDOUS PRESSURE** - Can cause serious injury and property damage.

**Air Pressure - Inadvertent Pump Operation Warning**

- Do not attempt to service or repair a pump while still connected to a pressurized air supply – Always ensure all possible air supplies to the pump are isolated (Shut-off) and disconnected.
- Isolation and / or disconnection of the pump air supply should be confirmed with a zero-reading pressure indication on the air supply line filter-pressure regulator unit.

**Process Fluid Pressure - Inadvertent Fluid Release (Spray) Warning**

- Before doing maintenance or service repair work ensure no process fluid pressure is present at the pump discharge (outlet) process connection. Note – the sudden release of pressurised process fluid can cause severe injury and damage to property.
- Relieve the pressure in the pump discharge pipe manifold by opening the process fluid drain line valve (if installed) alternatively open the valve at the end of the transfer pipeline also referred to as the dispensing or injection point valve.
- As a last resort carefully loosen the discharge (outlet) process connection at the pump and gently bleed-off the pressure in the pipeline. Note: take special care to prevent the process fluid from spraying.

**Important note:** Wear the correct personal protective equipment (PPE) when handling the pump.

 **HAZARDOUS MATERIALS** - Can cause serious injury or property damage.

- Display the process fluid “Material Safety Data Sheets” (MSDS) and applicable warning signage for clear identification of the hazards posed by the process fluid and the proper handling instructions.
- Do not attempt to perform any pump maintenance or service repairs if the pump has not been drained and flushed of all hazardous fluid.
- Do not package and return a pump to the manufacturer or supplier service center while it still contains hazardous process fluid. All local and national law safety code requirements for safe handling practices must be complied with.

**Important note:** Wear the correct personal protective equipment (PPE) when handling the pump.

 **CHEMICAL COMPATIBILITY** – confirm the chemical compatibility of the pump material selection.

- Ensure the chemical compatibility of the pump wetted parts and components is suited to the pumped process fluid and / or fluids used to flush the pump with.

**Important note:** chemical compatibility may change with both variations in temperature and concentration of the chemical(s) in the pumped process fluid. For specific proprietary chemical material compatibility consult with the chemical manufacturer and / or the supplier.

 **MAXIMUM OPERATING TEMPERATURE**

- The maximum stated temperatures for the pump materials are based on the maximum mechanical stress limits only. Note - the maximum operating temperature of certain chemicals will significantly further reduce maximum safe pump operating temperature, consult the chemical manufacturer for both the chemical compatibility of the process fluid and its operating temperature limits.

 **OPERATOR TRAINING** - is required to avoid severe injury and property damage

- Ensure all operator and maintenance personnel receive essential safety and skills training for the function, operation, service, and safe handling of the pump.

 **PUMP INSTALLATION** - refer to the diagram on the last page for a typical recommended air operated diaphragm pump installation

BSK pumps are designed to meet the most demanding applications and conformance with “best practice installation methods” will ensure best pump performance is achieved and avoid premature failures.

When planning the installation location take into consideration:

Ease of access: for routine operation and adjustments, maintenance work, breakdown repair and monitoring. - Note: pump operation and exhaust. - Contamination: process fluid ejected from the exhaust in the event of a diaphragm failure or spillage with a breakdown repair.

**Pump Suction**

- Plan the pump installation with the shortest hook-up distance to the process fluid tank or sump.
- Installing the shortest possible suction pipeline using the minimum number of components and pipe fittings (i.e. bends, elbows, reducers and couplings) reduces dynamic friction losses and extends the service life of the pump diaphragms while avoiding unnecessary material expenditure.
- “Self-priming” applications – the pump installation elevation must be with the pumps specified dynamic lift capacity. All connections and couplings must be air tight to avoid losing prime or lift capacity.
- Flexible hose or couplings must be of a reinforced design to avoid collapsing under the pumps vacuum suction pressure.
- “Flooded suction” applications – were the pump inlet pressure exceeds 3 meters (10 feet) of fluid column a pressure demand valve should be installed to prevent cavitation and extend diaphragm and check valve ball service life. Best practice installation calls for the installation of a quick action (¼ turn ball valve) isolation valve for pump maintenance

**Pump Discharge**

- The discharge pipe line size must not be smaller than the pump discharge process connection. A line size equivalent to or one size larger than the pump outlet process connection is best practice (i.e. Typical example - 2” pump size to 2” or 3” discharge line size).
- The positive displacement fluid flow from the air pump produces high surge velocities in the discharge pipe line and the pulsing action commonly referred to as “Water Hammer”. Installing a correctly sized “pulsation dampener” (surge vessel) into the discharge pipe line will greatly reduce friction losses and mechanical stresses

**Pipe Connections and Supports**

- Do not use the pump process connections for support – suction and discharge piping including all the pump system components must be supported by load bearing structures to ensure no mechanical stress is placed onto the pump.
- Flexible hose and / or bellow couplings must be used to connect the pump to rigid pipe installations, this ensures that no mechanical stress through pipe vibration or expansion is transmitted to pump.

**Important note:** Confirm the flexible coupling material chemically compatibly for the pumped process fluid.

 **PUMP PROTECTION**

- Do not run the pump dry (without process fluid) for extensive periods of time, dry run will cause unnecessary accelerated wear of the diaphragms and check valve balls and shortening the pump service life.
- If the pump stands for long periods of time between operations, it is recommended that the pump be flushed and cleaned each time after use. Flushing and cleaning the pump prevents the diaphragms and valves from being fouled with solids or

sticky fluid residues causing problems with the pumps next start-up.

- When exposed to freezing temperatures the pump must be flushed and drained of all fluid each time after use. If process fluid freezes inside the pump it will be damaged.
- Fluid media which is susceptible to setting, congealing, crystallization or freezing when left standing for any period of time must be flushed from the pump after its use with water or other compatible solvent to prevent pump damage.

#### **GENERAL DESCRIPTION**

- The BSK Air Operated Double Diaphragm Pump offers high volume delivery flow rates even at very low air pressures featuring a reliable stall resistant design. The pumps offer a broad range of material compatibility selection options suitable for the most demanding corrosive and abrasive industrial pumped fluid applications. The pump is based on a modular component design for the air motor and all fluid sections making it easy to operate and maintain with a minimum spare part holding requirement.
- The BSK air operated double diaphragm pump utilizes differential pressure in the air motor chambers to alternately create the suction and discharge pressure in the pump fluid chambers with the check ball valves producing a positive displacement fluid flow.
- When air pressure is applied to the pump it will begin the suction and discharge stroke cycling action which increases proportionally to the adjustment of the inlet air pressure and / or air flow volume.
- The pump continues to build pressure in the discharge (outlet) pipe line up until the line pressure is equal to the pump air inlet pressure at which point the pump will stop.

#### **OPERATING INSTRUCTIONS**

- Open the pump suction line valve to ensure it does not stall against a negative (vacuum) suction pressure. Open the pump discharge line valve to ensure it does not stall against a dead head pressure.
- Open the pump air supply isolation (shut-off) valve and the pump stroke action will begin to cycle.
- Using the air filter-pressure regulator installed on the pump air supply line adjust and set the air pressure and air flow capacity till the BSK pump delivers the required discharge process fluid flow rate.
- For automatic start / stop control observe that the air supply pilot valve opens and closes as per the pump control philosophy and that the pump flow rate is correct per the air supply settings.
- The pump will continue to run until either the air supply is shut-off or the discharge pipe line pressure is equal to the pump inlet air pressure at which point the pump stops.

 **Warning – do not run the pump at an air pressure higher than that indicated on the pump data plate.**

#### **PUMP MAINTENANCE**

 **Warning** – before doing any maintenance or service repair work to the pump always ensure that all fluid media and / or debris inside the pump have been drained and flushed out to avoid exposure to harmful chemicals which can cause serious injury. **Note: Turning and holding the pump upside down** will cause the check valve balls to drop open allowing process fluid inside the pump to drain out.

- Refer to the “exploded view assembly drawings” and the “bill of material part listing” which details the component part numbers and service kit information for the pump “Air Motor” and “Fluid” sections.
- For quick maintenance and shortest breakdown turnaround time repairs it is recommended that a complete service kit both the pump air motor and fluid sections be kept in stock.
- It is recommended that high wearing components and seals specifically marked with the **Delta Symbol “△”** in the pump exploded assemble diagrams and part lists be kept in stock as a minimum spare part holding requirement for the pump.
- The pump service kits are divided into two separate sections: The Air Motor Section and the Fluid Section for wetted parts.

- Each section is subdivided into a bill of material part list with a description for each component including a part number and a “list item number” which can be cross referenced to the pump section exploded assembly view drawing.
- Prior to performing any pump maintenance or service repairs ensure the work area is clean and free of dust and debris which may contaminate the pump spare parts and / or sensitive internal moving components.
- It is recommended that a preventative maintenance schedule to put in place for the pump and that all service activity and breakdown repairs be recorded.

### **PUMP DISASSEMBLY AND REASSEMBLY**

- Before starting disassembly, mark a line from each liquid chamber across to the centre body air chamber, similarly mark a line from each liquid chamber across to the inlet and outlet liquid manifold, doing so will assist with the proper alignment of these components with the pump reassembly.
- Lubricate all elastomer gaskets and their component seat / mating surfaces with grease before assembly.
- Before reusing any O-ring and Y-ring seals (including gaskets) carefully inspect them for any signs of wear and replace worn or damaged parts immediately.
- The **Y-ring seals** are so named for the “**raised lip**” on the edge of the seal and are indicated in the exploded view assembly diagram with the following cross-section view symbol (↵). Ensure that the lip of the seal is “**facing in the correct direction**” when assembled.
- When reassembling the pump fluid caps be sure to “Cross-torque” the bolts as they are tightened down.

**Important Note:** PTFE material seals and gaskets cannot be reused – unlike elastomer materials which return to their original form and size, PTFE material seals and gaskets remains compressed once used. Reusing PTFE material seals and gaskets with the pump reassembly introduces the risk of a process fluid leaks and / or air leaks occurring when the pump is put back into service.

### **TROUBLE SHOOTING**

#### **Pump will not operate correctly – fails to run or has a low output volume:**

- Check the air supply for sufficient air pressure and air flow volume capacity settings – note: the pump start-up air pressure requirement is slightly higher than its running pressure requirement, be sure to set-up the air supply accordingly. .
- Check the pump inlet air pressure verses the discharge line (outlet) pressure differential is at least 0.6 bar – if the pump runs against a closed discharge line valve or the process line is blocked the pump will reach its “Shut-off Head” and stop.
- Check the air line is not blocked or contaminated with debris – ensure the air motor components have not become fouled with debris obstructing their movement.
- Check the suction line valve (inlet) is not closed or that the suction line is not blocked – running the pump in this condition results in a negative suction pressure (vacuum) forming causing the pump to stall.
- Ensure the connection between the pump suction (inlet) manifold (B-02) and the fluid caps (B03) is properly sealed and there is no leakage.
- Inspect the pump suction check valve balls (B-04) and seats (B-05), these are wearing components and over time the balls reduce in size and / or become irregular in shape while the seat inner edges become larger or irregular – both conditions cause the check valve balls to stick
- Ensure the pump is not set to run to fast (excessively high stroke frequency) causing the pump to cavitate. Viscous fluids (thick liquids) flow slower and more time is required to allow the product to enter into the pump liquid chambers.

**Process Fluid is Forced-out of the Pump Air Exhaust**

Pumped process fluid leaking from the air exhaust indicates the hermetic seal separating the pump air motor section and the liquid chambers has failed – inspect the following components for the repair:

- Inspect the diaphragms (B-07, B-08) for rupture damage.
- Check if the bolts (B-10) securing the diaphragms have loosened and need to be retorqued.

**Air is Discharged with the Pumped Process Fluid**

- Check the bolted assembly for the suction manifold (B-02) and the fluid cap (B-03) joints is tight and properly torqued.
- Check the O-ring seals (B-06) are not worn and / or leaking.
- Check that the suction line connection to pump inlet is not leaking and that all the suction line fittings and system components connections are air tight.
- Ensure the diaphragm bolt assembly (B-10) is tight.

**Pump Reciprocating Motion Has Stopped with Extreme Exhaust Air Blow-by.**

If the pump has stalled and with excessively high air discharge at the exhaust it is an indication of a component failure in the air motor section.

- Check the Y-ring seals (A-05 (  )) for wear or damage.
- Check the O-ring seals (A-18) at the actuator (A-19)
- Check the O-ring seals (A-29) at the rod (A-30)
- Check the internal surface of the sleeve (A-32)

**AIR MOTOR SECTION (BA50-P1)**

PART LIST

Item	Desc	P/N	Mtl	Qty
A-01	Retainer	6232-1	SS	2
A-02	Plug	6219	PP	2
A-03	O-ring	6222-1	B	4
A-04	Sleeve	6220	Br	2
A-05	Y-ring	6221-3	B	2
A-06	Spool	6218	D	1
A-07	Housing	6299	AL	1
A-08	Screw	6236-2	SS	4
A-09	Insert	6205	Ce	1
A-10	Plate	6204	Ce	1
A-11	Gasket	6257	B	1
A-12	Plate	6215	AL	1

Item	Desc	P/N	Mtl	Qty
A-13	Gasket	6216	B	1
A-14	Plate	6206	Ce	1
A-15	Insert	6207	Ce	1
A-16	Center body	6213-4	AL	1
A-17	Rod	6471	D	1
A-18	O-ring	6474-2	U	4
A-19	Actuator	6473-1	SS	2
A-20	Sleeve	6470	Br	2
A-21	Backup	6290	AL	2
A-22	Screw	6236-1	CS	4
A-23	Air cap	6285-2	AL	1
A-24	Muffler	6297	CS	1

Item	Desc	P/N	Mtl	Qty
A-25	O-ring	6222-2	B	4
A-26	Gasket	6217	B	2
A-29	O-ring	6474-4	U	1
A-30	Rod	6466	CS	1
A-31	O-ring	6222-17	B	2
A-32	Sleeve	6469	D	1
A-33	Air cap	6286-2	AL	1
<b>Material Code:</b> SS=Stainless Steel PP=Polypropylene    B=NBR            Br=Brass AL=Aluminum Alloy    Ce=Ceramic    D=POM CS=Carbon steel        U=Urethane				

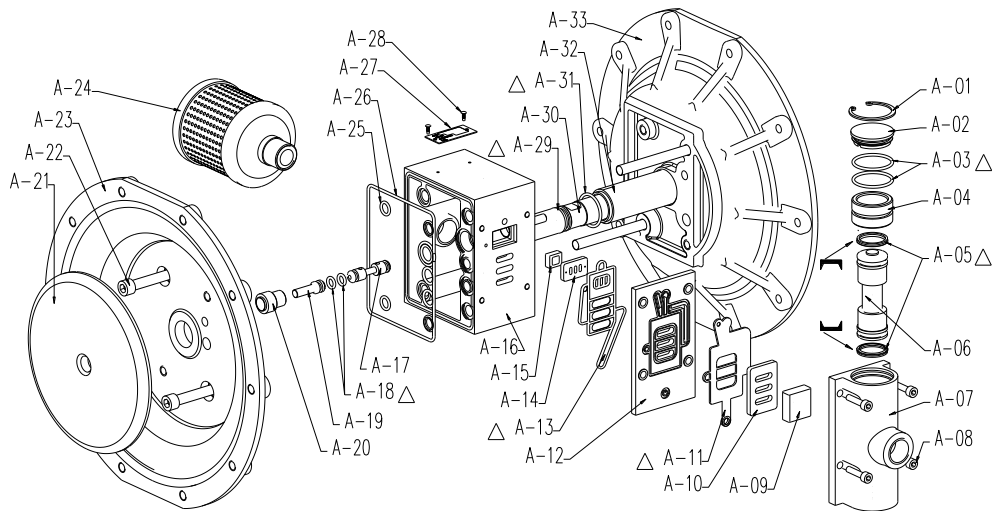

**Torque Requirements:**

A-08: 4.5-6.0 Nm

A-22: 15-25 Nm

Keep part with "Δ" on hand in addition to the service kits for fast repair and reduction of down time. These parts are included in the service kit

6395-BA50-P1

***Air Motor service***

**Air Motor Disassembly**

1. Remove housing (A-07). Releasing insert (A-09), plate (A-10), gasket (A-11), plate (A-12), gasket (A-13), plate (A-14) and insert (A-15).
2. Remove retainer (A-01) by a circlip plier. Releasing plug (A-02), sleeve (A-04) and spool (A-06).
3. Tear down bolt (A-22). Releasing air cap (A-23 and A-33), center body (A-16) and sleeve (A-32).
4. Remove sleeve (A-20) from center body (A-16). Releasing actuator (A-19) and rod (A-17)

**Air Motor Reassembly**

1. Inspect and replace old parts with new parts as necessary. Lubricate O-ring, Y-ring, gasket and mating parts.
2. Install O-ring (A-18) on actuator (A-19) and rod (A-17). Press a actuator (A-19) and rod (A-17) into sleeve (A-20) first. Then push them into center body (A-16). Press another actuator (A-19) into another sleeve (A-20) and push them into center body (A-16). NOTE: Rod (A-17) must crossover between both sleeve (A-20).
3. Install O-ring (A-31) on sleeve (A-32). Then push them into air cap (A-23)
4. Install O-ring (A-25) and gasket (A-26) on center body (A-16). Put center body assembly above air cap (A-23). Put air cap (A-33) above center body (A-16). Securing air cap (A-23 and A-33) with bolt (A-16).
5. Install O-ring (A-03) at inner groove on housing (A-07). Push sleeve (A-04) into housing (A-07).
6. Install new Y-ring (A-05) on spool (A-06) - **LIPS MUST FACE EACH OTHER.**
7. Install spool (A-06) into housing (A-07).
8. Install O-ring (A-03) on plug (A-02). Put them into housing (A-07). Assemble retainer (A-01) with a circlip plier.
9. Install insert (A-09) and a plate (A-10) into housing (A-07). Install insert (A-15) and plate (A-14) into body (A-16). NOTE: Assemble insert (A-09) with "dished" side toward plate (A-10). Assemble insert (A-15) with "dished" side toward plate (A-14). Assemble plate (A-10) with the most smooth side toward to insert (A-09). Assemble plate (A-14) with the most smooth side toward to insert (A-15).
10. Install gasket (A-11 and A-13) on plate (A-12).
11. Install plate (A-12) and housing (A-07) on body (A-16), securing with screw (A-08).

## FLUID SECTION

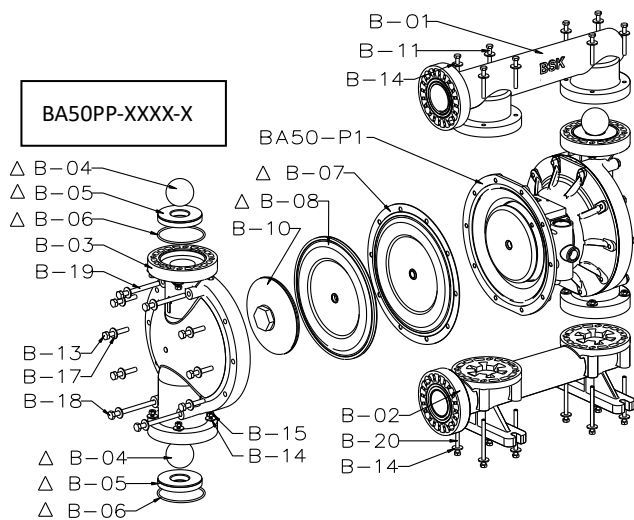
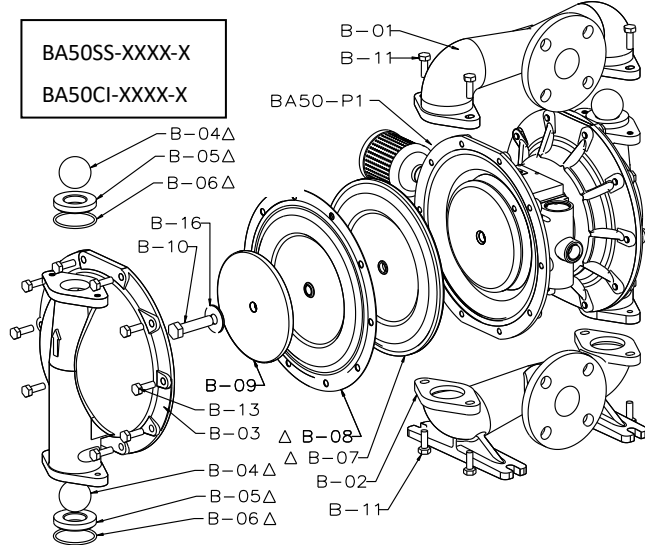
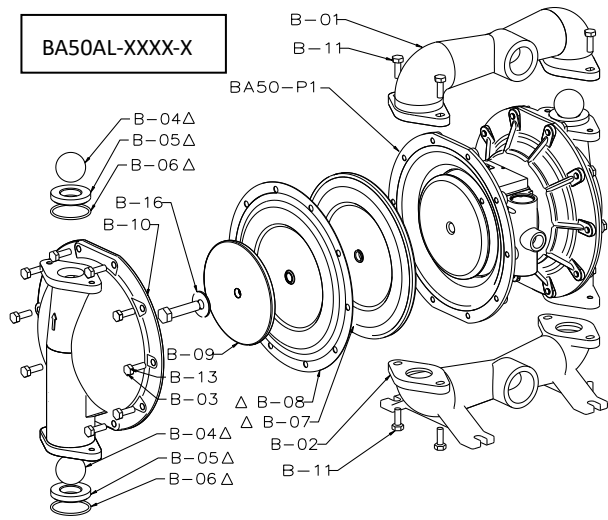

### Torque Requirements:

B-10: 80-95 Nm

B-11, B-13: 40-50 Nm (Metal pump)

B-11, B-13, B-14: 27-32 Nm (Non-metal pump)

Keep part with "Δ" on hand in addition to the service kits for fast repair and reduction of down time. These parts are included in the service kit 6396-X.

X=pump model - example

X=BA50AL-0TT3-A

### Wet Section Service

#### Disassembly

1. Remove manifold (B-02), O-ring (B-06), seat (B-05), ball (B-04).
2. Remove manifold (B-01), O-ring (B-06), seat (B-05), ball (B-04).
3. Remove fluid cap (B-03).
4. Remove screw (B-10). Releasing washer (B-09 and B-16), diaphragm (B-08)(B-07), washer (A-21), rod (A-30), O-ring (A-29).

#### Reassembly

- Reassemble in reverse order.
- Inspect and replace old parts with new parts as necessary.
- Lubricate O-ring (A-29) and rod (A-30) with grease.
- Apply Loctite 243 to threads of screw (B-10).

**Fluid cap/Manifold/Hardware**

Item	Description	Part Number	quantity	Material	BA50AL-XXXX-A	BA50SS-XXXX-C	BA50CI-XXXX-A	BA50CI-XXXX-C	BA50PP-XXXX-C
B-01	Manifold	6288	1	AL	Y				
B-01	Manifold	6348	1	SS		Y			
B-01	Manifold	6437	1	CI			Y		
B-01	Manifold	6437-3	1	CI				Y	
B-01	Manifold	6455-1	1	PP					Y
B-02	Manifold	6289	1	AL	Y				
B-02	Manifold	6349	1	SS		Y			
B-02	Manifold	6439	1	CI			Y		
B-02	Manifold	6439-3	1	CI				Y	
B-02	Manifold	6456-1	1	PP					Y
B-03	Fluid cap	6287	2	AL	Y				
B-03	Fluid cap	6347	2	SS		Y			
B-03	Fluid cap	6438	2	CI			Y	Y	
B-03	Fluid cap	6454-1	2	PP					Y
B-09	Washer	6290	2	AL	Y				
B-09	Washer	6397	2	CS			Y	Y	
B-09	Washer	6380	2	SS		Y			
B-10	Screw	6293	2	SS	Y	Y	Y	Y	
B-10	Screw	6453-1	2	PP					Y
B-11	Bolt	6476-1	8	CS	Y				
B-11	Bolt	6476-2	8	CS			Y	Y	
B-11	Bolt	6230-1	8	SS		Y			
B-11	Bolt	6230-13	8	SS					Y
B-13	Bolt	6476-1	20	CS	Y		Y	Y	
B-13	Bolt	6230-1	20	SS		Y			
B-13	Bolt	6230-19	12	SS					Y
B-14	Washer	6329-7	32	SS					Y
B-15	Nut	6231-5	16	SS					Y
B-16	Washer	6251	2	SS					
B-17	Washer	6329-8	20	SS					Y
B-18	Bolt	6230-18	4	SS					Y
B-19	Bolt	6230-14	4	SS					Y
B-20	Bolt	6230-17	8	SS					Y

**Material Code**

AL=Aluminum Alloy SS=Stainless Steel CS=carbon steel P=UPE  
 Sp=Santoprene® PV=PVDF T=PTFE T/c=PTFE(Cover) B=Nitrile  
 EP=EPDM Hy=Hytre!® PP=Polypropylene D=POM V=FKM

**"B-05" Seat Options**

Part Number	quantity	Material	BA50XX-DXXX-X	BA50XX-9XXX-X	BA50XX-SXXX-X	BA50XX-QXXX-X	BA50XX-CXXX-X	BA50PP-PXXX-C
6436-1	4	Sp		Y				
6291	4	D	Y					
6291-2	4	AL				Y		
6381	4	SS			Y			
6401	4	CS					Y	
6452-1	4	P						Y

**"B-04" Ball Options**

Part Number	quantity	Material	BA50XX-XTXX-X	BA50XX-X9XX-X	BA50XX-XHXX-X	BA50XX-XBXX-X	BA50XX-X8XX-X	BA50PP-XTXX-C	BA50PP-X9XX-C
6298	4	T	Y						
6292	4	Sp		Y					
6292-2	4	Hy			Y				
6292-3	4	B				Y			
6292-5	4	Sp/C					Y		
6451	4	T						Y	
6450-1	4	Sp							Y

**Diaphragm Options**

Item	Part Number	quantity	Material	BA50XX-XXTX-X	BA50XX-XX9X-X	BA50XX-XXHX-X	BA50XX-XXBX-X
B-07	6295	2	Sp	Y			
B-07	6294	2	Sp		Y		
B-07	6294-2	2	Hy			Y	
B-07	6294-4	2	B				Y
B-08	6296	2	T	Y			

**"B-06" O-ring Options**

Part Number	quantity	Material	BA50XX-XXX3-X	BA50XX-XXX1-X	BA50XX-XXX2-X	BA50PP-XXX1-C	BA50PP-XXX4-C	BA50PP-XXX5-C
6238-5	4	T	Y					
6222-19	4	B		Y				
6284-3	4	EP			Y			
6222-18	4	B				Y		
6281-7	4	T/C					Y	
6484-12	4	V						Y

## Dimensional Data

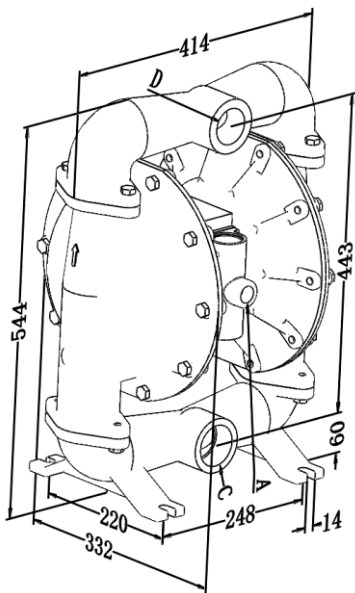

BA50AL-XXXX-X

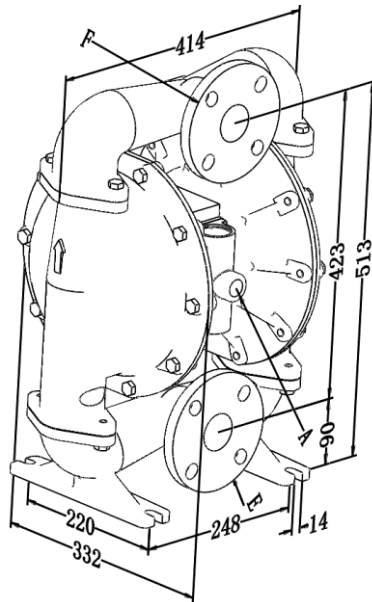

BA50SS-XXXX-X & BA50CS-XXXX-X

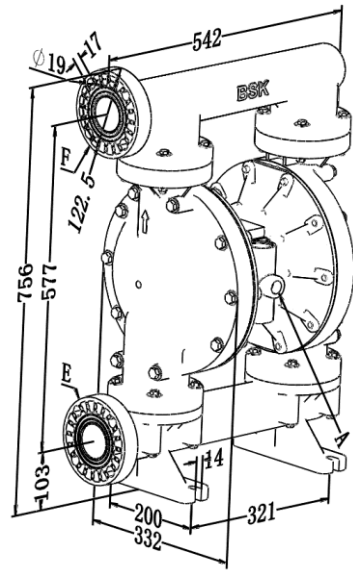

BA50PP-XXXX-C

A	AIR INLET	3/4 NPT
B	AIR EXHAUST	3/4 NPT
C	SUCTION PORT	2-11 BSP Rp
D	DISCHARGE PORT	2-11 BSP Rp
E	SUCTION PORT	2" ANSI/DIN FLANGE
F	DISCHARGE PORT	2" ANSI/DIN FLANGE

## TYPICAL INSTALLATION AND APPLICATIONS

This drawing is a typical generic example of a best practice air operated double diaphragm pump installation

