

The right choice for the ultimate yield!

LS ELECTRIC strives to maximize your profits in gratitude for choosing us as your partner.

Programmable Logic Control

Smart I/O Module

Smart I/O Series

User's Manual

Profibus-DP
DeviceNet
Rnet
Modbus
Ethernet
RAPIEnet



Safety Instructions

- Read this manual carefully before installing, wiring, operating, servicing or inspecting this equipment.
- Keep this manual within easy reach for quick reference.

LS ELECTRIC

Before using the product ...

For your safety and effective operation, please read the safety instructions thoroughly before using the product.

- ▶ Safety Instructions should always be observed in order to prevent accident or risk with the safe and proper use the product.
- ▶ Instructions are divided into “Warning” and “Caution”, and the meaning of the terms is as follows.



Warning

This symbol indicates the possibility of serious injury or death if some applicable instruction is violated.



Caution

This symbol indicates the possibility of severe or slight injury, and property damages if some applicable instruction is violated.

Moreover, even classified events under its caution category may develop into serious accidents relying on situations. Therefore we strongly advise users to observe all precautions properly just like warnings.

- ▶ The marks displayed on the product and in the user’s manual have the following meanings.



Be careful! Danger may be expected.



Be careful! Electric shock may occur.

- ▶ The user’s manual even after read shall be kept available and accessible to any user of the product.

Safety Instructions for Design Process

Caution

- ▶ **Design the analog input / output signal or pulse input / output line at least 100mm away from high voltage line or power line so that it is not affected by noise or magnetic field change.** It may cause malfunction due to noise.
- ▶ **If there is a lot of vibration in the installation environment, take measures to prevent direct vibration from being applied to the PLC.** It may cause electric shock, fire or malfunction.
- ▶ **If metallic dust is present in the installation environment, take measures to prevent metallic dust from entering the product.** It may cause electric shock, fire or malfunction.

Safety Instructions on Installation Process

Caution

- ▶ **Use PLC only in the environment specified in PLC manual or general standard of datasheet.**
If not, electric shock, fire, abnormal operation of the product may be caused.
- ▶ **Before install or remove the module, be sure PLC power is off.** If not, electric shock or damage on the product may be caused.
- ▶ **Be sure that every module is securely attached after adding a module or an extension connector.** If the product is installed loosely or incorrectly, abnormal operation, error or dropping may be caused. In addition, contact failures under poor cable installation will be causing malfunctions as well.
- ▶ **Make sure that the I / O connector is securely fastened.** It may cause wrong input or output.

Safety Instructions for Wiring Process

Warning

- ▶ **Prior to wiring works, make sure that every power is turned off.** If not, electric shock or damage on the product may be caused.

Caution

- ▶ **Check rated voltages and terminal arrangements in each product prior to its wiring process.** Applying incorrect voltages other than rated voltages and misarrangement among terminals may cause fire or malfunctions.
- ▶ **Secure terminal screws tightly applying with specified torque.** If the screws get loose, short circuit, fire or abnormal operation may be caused. Securing screws too tightly will cause damages to the module or malfunctions, short circuit, and dropping.
- ▶ **Be sure to earth to the ground using Class 3 wires for PE terminals which is exclusively used for PLC.** If the terminals not grounded correctly, abnormal operation or electric shock may be caused.
- ▶ **Don't let any foreign materials such as wiring waste inside the module while wiring,** which may cause fire, damage on the product or abnormal operation.

Safety Instructions for Test-Operation and Maintenance

Warning

- ▶ **Don't touch the terminal when powered.** Electric shock or abnormal operation may occur.
- ▶ **Prior to cleaning or tightening the terminal screws, let all the external power off including PLC power.** If not, electric shock or abnormal operation may occur.

Caution

- ▶ **Do not make modifications or disassemble each module.**
Fire, electric shock or abnormal operation may occur.
- ▶ **Prior to installing or disassembling the module, let all the external power off including PLC power.** If not, electric shock or abnormal operation may occur.
- ▶ **Keep any wireless equipment such as walkie-talkie or cell phones at least 30cm away from PLC.** If not, abnormal operation may be caused.

Safety Instructions for Waste Disposal

Caution

- ▶ **Product or battery waste shall be processed as industrial waste.** The waste may discharge toxic materials or explode itself.

Revision History

Version	Date	Revised Contents	Page
V 1.0	'02.04	* First Edition	-
V 1.1	'03.07	* TR 0.5A Source Output module (16, 32 and hybrid) added	-
V 1.2	'03.12	* TR 0.5A Sink Output module (32, hybrid) added	-
V 1.3	'04.06	* TR 0.5A Sink Output module (16) added	-
V 1.4	'05.07	* Analog input/output module (A/D 8 ch, D/A 4 ch) added	9-1 ~ 9-26
V1.5	'07.05	* Smart I/O Dnet function (Quick/Dummy mode) added * XG-PD setting contents revised * Extension type Smart I/O Pnet/Dnet adapter (XPL/XDL-BSSA) contents revised	1-4 ~ 1-8, 2-2 4-18 ~ 4-19 6-22,6-32 ~ 6-46
V1.6	'08.11	* Smart I/O Rnet function (Latch/Clear) added * Extension type Smart I/O Rnet adapter (XRL-BSSA) added * XGR added * Address of headquarter changed	1-9,3-7 1-10, 2-28, 3-12 1-2,1-12
V1.7	'09.06	* Extension type Smart I/O Enet adapter (XEL-BSSA/BSSB) contents revised	2-30, 2-35~2-36, 3-13~3-14, 10-1 ~ 10-29 A-7~A-11, A-27~A-32
V1.8	'10.05	* Extension type Smart I/O module added * Communication module specification error modified * Parameter setting method of extension type Smart I/O (Pnet/Dnet/Rnet) adapter added	Ch2.2.1, Ch2.6.5~2.6.6 Ch2.7.2~2.7.3 Ch5.4,Ch6.4, Ch7.4 A.3~A.5
V1.9	'10.10	* Extension type Analog I/O module added (XBE-DC16B, XBE-RY08B) * XEL-BSSA Notes revised * XEL-BSSB periodic communication parameter setting method added	1-6, 1-8, 1-10, 1-12, 2-2
V2.0	'12.08	* Page number and contents error revised in index	Page : 10-5, 11-9 ~ 11-11 11-15 ~ 11-17 Contents : CH13.2
V2.1	'12.11	* Extension type Smart I/O module added - XBF-AD04C / DV04C / DC04C / AD08A * Parameter setting method of extension type added	Ch10(Enet), APPENDIX (XEL-BSSA/B)
V2.2	'13.12	* Extension type Smart I/O module added - XBF-AD04C / DV04C / DC04C * Parameter setting method of extension type added * Domain of homepage changed	Ch5(Pnet), APPENDIX (XPL-BSSA) -

V2.3	'14.02	* Parameter setting method of extension type added - XBF-AD04C / DV04C / DC04C * Parameter setting method of extension type changed	Ch7(Rnet), APPENDIX (XRL-BSSA)
V2.4	'15.11	* Communication module specification error modified	APPENDIX (XEL-BSSB)
V2.5	'15.12	* Snet stand-alone removable type module added	1-11
V2.6	'16.04	* Smart I/O RAPIEnet mmodule added	Ch11(RAPIEnet)
V2.7	'20.05	* Format and contents modification according to the change of company name (LSIS → LS ELECTRIC)	-

© Table of Content ©

Chapter 1 Overview

1.1 How to use the User's Manual -----	1-1
1.2 Characteristics of Smart I/O -----	1-3
1.3 Product Configuration of Smart I/O -----	1-4
1.3.1 Type name indication -----	1-4
1.3.2 Module Specifications-----	1-5
1.3.3 Compatibility list according to Smart I/O Module version-----	1-14
1.4 Notice in using -----	1-15

Chapter 2 Product Specification

2.1 General Specification-----	2-1
2.2 Power Specification-----	2-2
2.2.1 Performance Specification-----	2-2
2.3 Digital Input Module Specification-----	2-3
2.3.1 DC16 points stand-alone type input module (Source/Sink) -----	2-3
2.3.2 DC32 points stand-alone type input module (Source/Sink) -----	2-4
2.3.3 DC8 points modular type input module (Source/Sink) -----	2-5
2.3.4 DC16 points modular type input module (Sink/Source) -----	2-6
2.3.5 DC32 points modular type input module (Source/Sink) -----	2-7
2.4 Digital Output Module Specification-----	2-8
2.4.1 16 points relay output stand-alone type module -----	2-8
2.4.2 16 points transistor stand-alone type output module (0.1 Sink) -----	2-9
2.4.3 16 points transistor stand-alone type output module (0.5A Sink) -----	2-10
2.4.4 16 points transistor stand-alone type output module (0.5A Source) -----	2-11
2.4.5 32 points transistor stand-alone type output module (0.1A Sink) -----	2-12
2.4.6 32 points transistor stand-alone type output module (0.5A Source) -----	2-13
2.4.7 32 points transistor stand-alone type Output Module (0.5A Sink) -----	2-14
2.4.8 8 points relay modular type output module -----	2-15
2.4.9 8 points relay modular type output module(B type) -----	2-16
2.4.10 16 points relay modular type output Module -----	2-17
2.4.11 8 points transistor modular type output Module (0.5A Sink) -----	2-18
2.4.12 16 points transistor modular type output Module (0.5A Sink) -----	2-19
2.4.13 32 points transistor modular type output module (0.2A Sink) -----	2-20
2.5 Digital I/O combined Module Specification-----	2-21
2.5.1 32point I/O combined module (DC16/TR16 point) -----	2-21
2.5.2 32point I/O combined module (DC16/TR16 point) -----	2-22
2.5.3 32point I/O combined module (DC16/TR16 point) -----	2-23
2.6 Modular type analogue module specification -----	2-24
2.6.1 Modular type analogue output module -----	2-24
2.6.2 Modular type analogue input module -----	2-26
2.6.3 Modular type RTD sensor module (XBF-RD04A) -----	2-29
2.6.4 Thermocouple input module (XBF-TC04S) -----	2-30
2.6.5 Analog I/O module (XBF-AH04A) -----	2-31

2.7	Communication Module Specification	2-32
2.7.1	Profibus-DP Module Specification	2-32
2.7.2	DeviceNet Module Specification	2-33
2.7.3	Rnet Module Specification	2-34
2.7.4	Snet Module Specification	2-35
2.7.5	Enet Module Specification	2-36
2.7.6	RAPIEnet Module Specification	2-37
2.8	Communication Cable Specification	2-38
2.8.1	Profibus-DP cable specification	2-38
2.8.2	DeviceNet Cable Specification	2-39
2.8.3	Rnet Cable Specification	2-40
2.8.4	Snet Cable Specification	2-41
2.8.5	Enet Cable Specification	2-42
2.9	Terminating.....	2-44
2.9.1	Profibus-DP terminating.....	2-44
2.9.2	DeviceNet terminating.....	2-44
2.9.3	Rnet terminating.....	2-45
2.9.4	Snet terminating.....	2-46

Chapter 3 System Configuration

3.1	Notices in selecting module.....	3-1
3.2	Names of Each Part.....	3-2
3.2.1	Basic system configuration.....	3-2
3.2.2	Names of each part of Smart I/O series.....	3-4
3.3	I/O Wiring Diagram of Communication Module.....	3-15
3.3.1	External connection diagram of Smart I/O module.....	3-15
3.4	Examples of System Configuration.....	3-31
3.4.1	Profibus-DP system.....	3-31
3.4.2	DeviceNet system	3-32
3.4.3	Rnet system	3-33
3.4.4	Snet system	3-34
3.4.5	RAPIEnet System	3-35

Chapter 4 Communication Programming

4.1	Overview.....	4-1
4.1.1	High-speed Link	4-1
4.1.2	Function Block(GLOFA-GM) / Instruction(MASTER-K)	4-2
4.2	High Speed Link.....	4-3
4.2.1	Overview.....	4-3
4.2.2	High Speed Link TRX data processing.....	4-4
4.2.3	Operation order by High Speed Link.....	4-5
4.2.4	GMWIN's setting of High Speed Link parameter	4-6
4.2.5	KGLWIN Link parameter setting.....	4-14
4.2.6	XG5000 Link parameter setting.....	4-18
4.2.7	High Speed Link Communication status flag information (GM/MK)	4-20
4.2.8	High Speed Link Communication status flag information (XGT)	4-23
4.2.9	High Speed Link Speed calculation.....	4-24
4.3	Function Block.....	4-28
4.3.1	Overview.....	4-28
4.3.2	Start of GMWIN Function Block.....	4-28
4.4	Execution of KGLWIN Instruction	4-30

Chapter 5 Profibus-DP Communication

5.1 Overview----- 5-1

5.2 Communication Specification----- 5-1

5.3 Basic Performance----- 5-2

 5.3.1 Overview----- 5-2

 5.3.2 Operation by High Speed Link ----- 5-2

 5.3.3 SyCon ----- 5-3

 5.3.4 Insertion of master module----- 5-4

 5.3.5 Master module setting----- 5-5

 5.3.6 Insertion of slave----- 5-6

 5.3.7 Slave Configuration ----- 5-7

 5.3.8 Bus parameter setting----- 5-8

 5.3.9 Device allocation----- 5-9

 5.3.10 Configuration download - ----- 5-11

 5.3.11 High Speed Link parameter setting in GMWIN----- 5-12

 5.3.12 High Speed Link information in GMWIN----- 5-16

 5.3.13 High Speed Link parameter setting in KGLWIN----- 5-20

 5.3.14 High Speed Link Parameter setting in the XG5000 ----- 5-23

5.4 Analog I/O module Parameter Setting ----- 5-24

 5.4.1 XPL-BSSA Analog I/O module Parameter Setting ----- 5-24

 5.4.2 How to set XPL-BSSA analog I/O module parameter ----- 5-27

5.5 Program example ----- 5-30

 5.5.1 GLOFA GM series ----- 5-30

 5.5.2 Master-K series ----- 5-37

 5.5.3 XGT series communication ----- 5-40

Chapter 6 DeviceNet Communication

6.1 Overview----- 6-1

6.2 Communication Specification----- 6-2

6.3 Communication Parameter Setting----- 6-3

 6.3.1 High Speed Link ----- 6-4

 6.3.2 High Speed Link Communication status Flag Information ----- 6-4

 6.3.3 High Speed Link Information Monitor (GMWIN) ----- 6-6

 6.3.4 High Speed Link service (GMWIN) ----- 6-8

 6.3.5 High Speed Link Information Monitor (KGLWIN) ----- 6-18

 6.3.6 Sequence of High-speed Link setting (KGLWIN) ----- 6-20

 6.3.7 High Speed Link Operation (KGLWIN) ----- 6-22

 6.3.8 Sequence of High-speed Link setting (XG5000) ----- 6-23

6.4 Analog I/O module Parameter Setting ----- 6-52

 6.4.1 XDL-BSSA Analog I/O module Parameter Setting ----- 6-52

 6.4.2 How to set XDL-BSSA analog I/O module parameter ----- 6-55

 6.4.3 Example of Parameter Setting ----- 6-57

6.5 Program Examples----- 6-58

 6.5.1 GLOFA-GM series----- 6-58

 6.5.2 MASTER-K series ----- 6-62

 6.5.3 XGT series ----- 6-67

Chapter 7 Rnet Communication

7.1 Overview-----	7-1
7.2 Communication Specification-----	7-1
7.3 Communication Parameter Setting-----	7-2
7.3.1 Overview-----	7-2
7.3.2 High Speed Link communication status flag-----	7-3
7.3.3 GMWIN High Speed Link setting-----	7-3
7.3.4 KGLWIN Link setting-----	7-11
7.3.5 XGT Rnet's HS Link parameter setting -----	7-21
7.4 Analog I/O module Parameter Setting -----	7-27
7.4.1 XRL-BSSA analog I/O module Parameter Setting -----	7-27
7.4.2 How to set XRL-BSSA analog I/O module parameter -----	7-33
7.4.3 Example of parameter setting -----	7-33
7.5 Program Examples-----	7-35
7.5.1 GLOFA-GM series -----	7-35
7.5.2 MASTER-K series -----	7-37
7.5.3 XGT series -----	7-40

Chapter 8 Modbus Communication

8.1 Overview-----	8-1
8.2 Communication Specification-----	8-1
8.2.1 ASCII Mode -----	8-1
8.2.2 RTU Mode -----	8-1
8.2.3 Station no.(address) Area -----	8-2
8.2.4 Function Code Area -----	8-2
8.2.5 Data area -----	8-2
8.2.6 Error Check(LRC Check/CRC Check) Area -----	8-3
8.2.7 Function Code Type and Memory Mapping -----	8-3
8.2.8 Modbus Addressing Regulation -----	8-4
8.2.9 Data size -----	8-5
8.2.10 Wiring diagram -----	8-5
8.3 Communication Parameter Setting-----	8-6
8.3.1 GLOFA-GM series -----	8-6
8.3.2 MASTER-K series -----	8-9
8.3.3 XGT series -----	8-11
8.4 Function Block-----	8-17
8.4.1 GLOFA-GM series -----	8-17
8.4.2 MASTER-K series -----	8-33
8.5 Program Examples-----	8-37
8.5.1 GLOFA-GM series -----	8-37
8.5.2 MASTER-K series -----	8-47
8.5.3 XGT series -----	8-49

Chapter 9 Analogue Module for Profibus-DP

9.1 Analog Input Module-----	9-1
9.1.1 Performance specification -----	9-1
9.1.2 Name and role of each part-----	9-2
9.1.3 Characteristic of input transformation-----	9-4
9.1.4 Filter Function-----	9-7
9.1.5 Installing and wiring-----	9-8
9.1.6 Program example-----	9-10

9.2 Analogue Output Module-----	9-13
9.2.1 Performance specification -----	9-13
9.2.2 Name and role of each part-----	9-14
9.2.3 I/O transformation characteristic-----	9-16
9.2.4 Output When error occurs-----	9-18
9.2.5 Installing-----	9-19
9.2.6 Example of program-----	9-21
9.3 Checking Error-----	9-24
9.3.1 Type of error-----	9-24
9.3.2 Checking error-----	9-24
9.3.3 RDY LED is extinguished. -----	9-25
9.3.4 CPU module can't read transformation value-----	9-25
9.3.5 Analog value's relation is not consistent with digital value. -----	9-26
9.3.6 Breakdown in hardware of analog module. -----	9-26

Chapter 10 Ethernet Communication

10.1 Introduction -----	10-1
10.2 Communication Dimension -----	10-2
10.3 Module Parameter Setting -----	10-3
10.3.1 BootpServer -----	10-3
10.3.2 Parameter setting -----	10-4
10.3.3 Check points before running BootpServer -----	10-5
10.4 Modbus/TCP communication -----	10-9
10.4.1 I/O data assignment -----	10-9
10.4.2 Communication Setting -----	10-10
10.4.3 XGT Series communication -----	10-12
10.5 EtherNet/IP communication -----	10-21
10.5.1 I/O data assignment -----	10-21
10.5.2 Communication Setting -----	10-24
10.5.3 XGT Series communication -----	10-25

Chapter 11 RAPIEnet Communication

11.1 Overview -----	11-1
11.1.1 Characteristics of Smart I/O RAPIEnet -----	11-2
11.1.2 RAPIEnet Smart I/O Product Configuration -----	11-3
11.2 Product Specification -----	11-4
11.2.1 Communication Specification -----	11-4
11.2.2 Communication Cable Specification -----	11-5
11.2.3 Digital I/O -----	11-7
11.2.4 Analog I/O -----	11-10
11.2.5 Characteristic of I/O conversion -----	11-12
11.2.6 Analog Accuracy -----	11-18
11.2.7 Functions of Analog Module -----	11-20
11.3 System Configuration -----	11-24
11.3.1 Names of Each part -----	11-24
11.3.2 System Configuration -----	11-27
11.4 Communication Setting -----	11-28
11.4.1 Smart I/O RAPIEnet Parameter Settings -----	11-29
11.4.2 High-speed link setting -----	11-47
11.4.3 Writing Parameters and Link Enable -----	11-56
11.4.4 Smart I/O Communication Setting Example -----	11-57
11.5 Diagnostics Functions -----	11-73
11.5.1 S/W diagnostic functions -----	11-73
11.5.2 H/W diagnostic functions -----	11-84

Chapter 12 Installation and Wiring

12.1 Installation-----	12-1
12.1.1 Installation Environment-----	12-1
12.1.2 Notices in installing Profibus-DP module-----	12-2
12.1.3 Notices in installing DeviceNet module-----	12-3
12.1.4 Notices in installing Rnet module-----	12-9
12.1.5 Notices in installing Modbus module-----	12-10
12.1.6 Notices in Handling-----	12-11
12.2 Wiring-----	12-15
12.2.1 Power wiring-----	12-15
12.2.2 I/O Device Wiring-----	12-17
12.2.3 Grounding wiring-----	12-17
12.2.4 Cable specification for wiring-----	12-18

Chapter 13 Maintenance and Repair

13.1 Repair and Check-----	13-1
13.2 Daily Check-----	13-2
13.3 Regular Check-----	13-4

Chapter 14 Trouble Shooting

14.1 Basic Procedure of Trouble Shooting-----	14-1
14.2 Trouble Shooting-----	14-2
14.2.1 Action method when POWER LED is OFF -----	14-3
14.2.2 Action method when ERR LED is blinking-----	14-4
14.2.3 Action method when RUN LED is OFF -----	14-5
14.2.4 Action method when I/O part does not work normally-----	14-6
14.2.5 Action method when Program Write does not work -----	14-8
14.2.6 SyCon connection error -----	14-9
14.2.7 XG5000 connection error -----	14-10
14.2.8 Communication error with slave -----	14-11
14.3 Trouble Shooting Questionnaire-----	14-12

Appendix

A.1 Communication Terminology-----	A-1
A.1.1 Profibus-DP -----	A-1
A.1.2 DeviceNet -----	A-3
A.1.3 Rnet -----	A-4
A.1.4 Modbus -----	A-6
A.1.5 Ethernet -----	A-7
A.2 External Dimension-----	A-12
A.3 Expansion type analogue module parameter setting method (XDL-BSSA) -----	A-16
A.3.1 Analogue I/O module parameter setting standard -----	A-16
A.3.2 Analog parameter setting method -----	A-19
A.4 How to set expansion analog module parameter (XPL-BSSA) -----	A-23
A.4.1 Configuration of analog I/O module parameter -----	A-23
A.4.2 How to set an analog parameter -----	A-25
A.5 How to set expansion analog module parameter (XRL-BSSA) -----	A-28
A.5.1 Analog I/O module parameter setting(Only for O/S V1.3 or higher) -----	A-28
A.5.2 Analog I/O module parameter setting(Only for O/S V1.2 or less) -----	A-33

A.6 Expansion Analog Module Parameter Setting Method (XEL-BSSA) ----- A-37
A.6.1 Analog expansion module parameter setting criteria ----- A-37
A.7 Expansion Analog Module Parameter Setting Method (XEL-BSSB) ----- A-43
A.7.1 Analog expansion module parameter setting criteria ----- A-43

Chapter 1 Overview

1.1 How to use the User's Manual

This User's Manual provides the information such as product specification, performance and operation method needed to use PLC System composed of Smart I/O module.

The User's Manual is composed of as follows.

CHAP.1 Overview

Describes the configuration of the user's manual, product characteristics and terminology.

CHAP.2 Product Specification

Describes common specification of each product used for Smart I/O series.

CHAP.3 System Configuration

Describes the kinds of product available for Smart I/O series and system configuration method.

CHAP.4 Communication Programming

Describes common communication program operating method to act Smart I/O module.

CHAP.5 Profibus-DP Communication

Describes basic communication method of Profibus-DP (Pnet) communication module.

CHAP.6 DeviceNet Communication

Describes basic communication method of DeviceNet (Dnet) communication module.

CHAP.7 Rnet Communication

Describes basic communication method of FIELDBUS (RNET) communication module.

CHAP.8 Modbus Communication

Describes basic communication method of Modbus (Snet) communication module.

CHAP.9 Analogue I/O Module

Describes performance specification, each parts' names and program examples of analogue I/O module.

CHAP.10 Ethernet communication

Describes basic communication method of Ethernet (Enet) communication module.

CHAP.11 RAPIEnet communication

Describes basic communication method of RAPIEnet communication module.

CHAP.12 Installation and Wiring

Describes installation and wiring method, and notices to make sure of the reliability of PLC system.

CHAP.13 Maintenance and Repair

Describes check list and method to run PLC system normally for a long term.

CHAP.14 Trouble Shooting

Describes various errors to be occurred while using the system and the action to solve the problem.

Appendix

Here describes the product terminology and external dimension for system installation.

If you want to write programs, refer to the following manuals.

- GLOFA PLC Instruction manual
- GLOFA PLC GMWIN user manual
- GLOFA PLC GM3/4 user manual
- GLOFA PLC GM6 user manual

- MASTER-K Instruction
- MASTER-K 200S/300S user manual
- KGLWIN user manual

- XG5000 user manual
- XGK Instruction manual
- XGI/XGR Instruction manual
- XGK CPU manual
- XGI/XGR CPU manual
- XGT Dnet I/F module user manual
- XGT Pnet I/F module user manual
- XGT Cnet I/F module user manual
- XGT Rnet I/F module user manual
- XGT Enet I/F module user manual
- XGT RAPIEnet I/F module user manual

When you make system of GLOFA-GM/MASTER-K and Smart I/O module, consider the followings. The following is CPU or software version for operating the module.

- GLOFA PLC GMWIN program Tool: upper Ver.4.03
- GLOFA GMR CPU : more than Ver. 2.2
- GLOFA GM1/2 CPU : more than Ver. 3.2
- GLOFA GM3 CPU : more than Ver. 2.7
- GLOFA GM6 CPU : more than Ver. 2.1

- MASTER-K PLC KGLWIN programming Tool : more than Ver. 3.41
- MASTER-K K1000S CPU : more than Ver. 3.2
- MASTER-K K300S CPU : more than Ver. 3.4
- MASTER-K K200S CPU : more than Ver. 2.4

- Frame Editor : more than Ver. 2.01

Remark

1) This manual is written for GMWIN V4.04, KGLWIN V3.6, Frame editor V2.01 and XG5000 V4.0.

1.2 Characteristics of Smart I/O

The characteristics of Smart I/O series is as follows.

- (1) Product design based on International Electrotechnical Commission (IEC 61131) (GLOFA series in common)
 - Easy support to programming device
 - Standard language (IEC 61131-3) provided (IL / LD / SFC)
- (2) Open network by selecting international standard communication protocol.
- (3) Available to communicate with remote master module independently without power module/CPU module.
- (4) Available to set maximum 32 ~ 64 stations.
 - Maximum 64 stations (Rnet, Dnet, RAPIEnet)
 - Maximum 32 stations (Pnet, Snet)
- (5) Enables to save the cost for installation and maintenance.
- (6) Various system configuration and simple maintenance and repair.
- (7) Easy to change the system.
- (8) Compatible with other maker's product.
 - Available to connect Smart I/O to other maker's master.
- (9) Easy to set the system as the station address setting by hardware is available.
- (10) Simple communication programming.
 - Using the GMWIN/KGLWIN High-speed link parameter
 - But for Modbus (Snet), using function block(GMWIN, XGLWIN) or P2P(XG5000)
- (11) Supports various I/O.
- (12) Supports various OPEN type communication method. (RAPIEnet, Rnet is only for LS products.)
 - Pnet, Dnet, Snet, Enet
- (13) Easy to configure system and use
 - integrating PLC: Packaged by one unit including CPU, I/O and communication function.
 - extension PLC: it is available to configure communication or I/O diversely.
- (14) Provides the online network status detection function.
 - Available to know the remote module status through high speed link monitor.
 - In case of XGT system (RAPIEnet, Pnet, Dnet), it is available to check more diverse module instantly.
- (15) Supports high speed communication.
- (16) Flexible communication relation is available as the speed shall be set automatically according to the speed of master.
 - Pnet, Dnet etc.

1.3 Product Configuration of Smart I/O

1.3.1 Type Name Indication

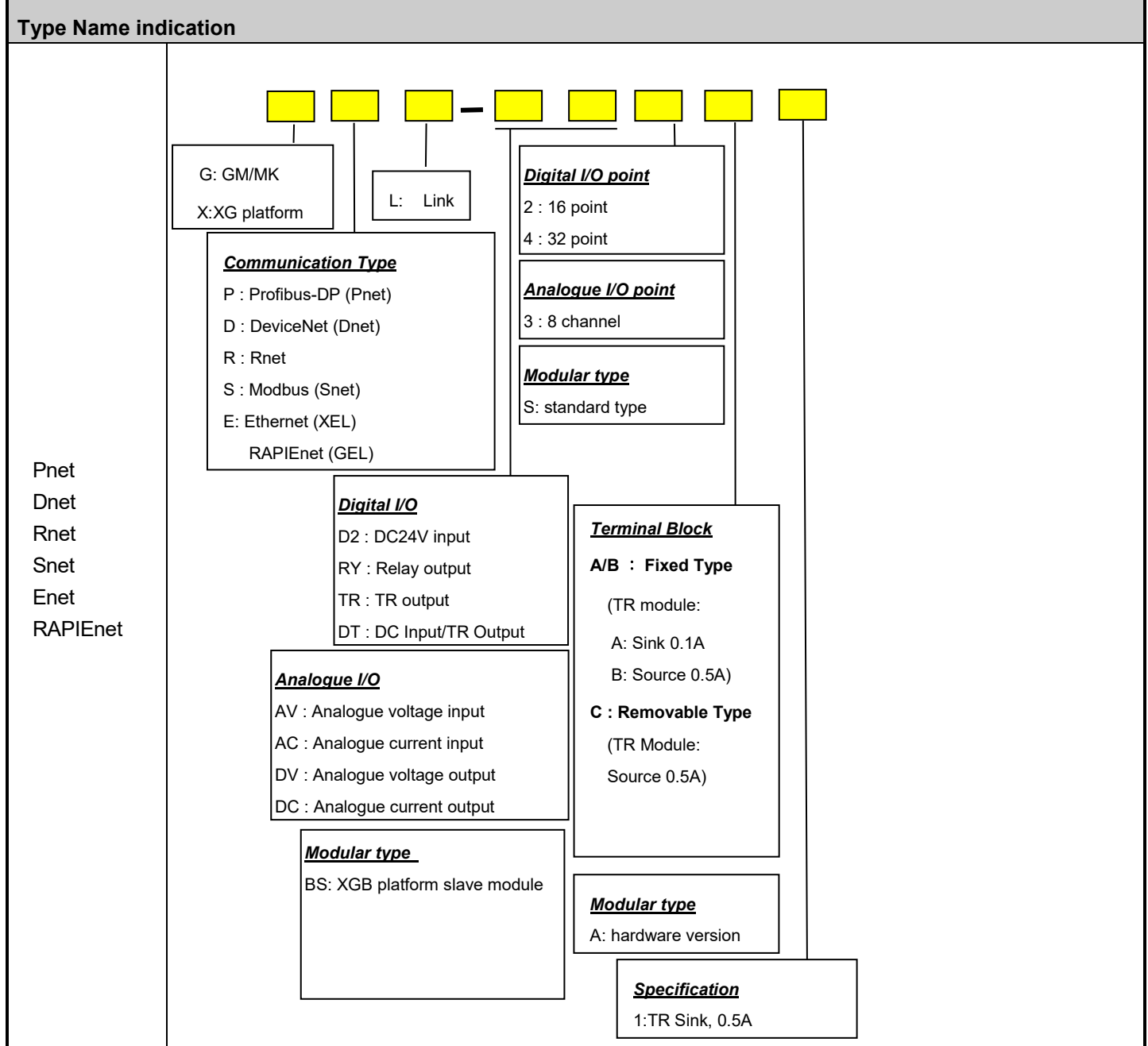

1.3.2 Module Specifications

1) Pnet

(1) Stand-alone type

Classification	Type name	Specification	
TR output	Fixed	GPL-TR2A	DC24V, TR output 16 points (Source 0.1A)
		GPL-TR2A1	DC24V, TR output 16 points (Sink 0.5A)
		GPL-TR2B	DC24V, TR output 16 points (Source 0.5A)
		GPL-TR4A	DC24V, TR output 32 points (Sink 0.1A)
		GPL-TR4A1	DC24V, TR output 32 points (Sink 0.5A)
		GPL-TR4B	DC24V, TR output 32 points (Source 0.5A)
	Removable	GPL-TR2C	DC24V, TR output 16 points (Source 0.5A)
		GPL-TR2C1	DC24V, TR output 16 points (Sink 0.5A)
		GPL-TR4C	DC24V, TR output 32 points (Source 0.5A)
		GPL-TR4C1	DC24V, TR output 32 points (Sink 0.5A)
Hybrid	Fixed	GPL-DT4A	DC24V, DC input 16 points /TR output 16 points (Sink 0.1A)
		GPL-DT4A1	DC24V, DC input 16 points /TR output 16 points (Sink 0.5A)
		GPL-DT4B	DC24V, DC input 16 points /TR output 16 points (Source 0.5A)
	Removable	GPL-DT4C	DC24V, DC input 16 points /TR output 16 points (Source 0.5A)
		GPL-DT4C1	DC24V, DC input 16 points /TR output 16 points (Sink 0.5A)
Relay output	Fixed	GPL-RY2A	DC24V(Rating), Relay output 16 points
	Removable	GPL-RY2C	DC24V(Rating), Relay output 16 points
DC input	Fixed	GPL-D22A	DC24V(Rating), DC input 16 points
		GPL-D24A	DC24V(Rating), DC input 32 points
	Removable	GPL-D22C	DC24V(Rating), DC input 16 points
		GPL-D24C	DC24V(Rating), DC input 32 points
Analog input	Removable	GPL-AV8C	Analog voltage input, 8 channels
		GPL-AC8C	Analog current input, 8 channels
Analog output	Removable	GPL-DV4C	Analog voltage output, 4 channels
		GPL-DC4C	Analog current output, 4 channels

(2) Modular type

Classification	Type name	Specification
Communication adapter	XPL-BSSA	Pnet I/F adapter
Modular I/O	XBE-DC08A	DC24V input module 8 points (Source/Sink type)
	XBE-DC16A/B	DC24V input module 16 points (Sink/Source type)
	XBE-DC32A	DC24V input 32 points
	XBE-RY08A/B	Relay output module 8 points
	XBE-RY16A	Relay output module 16 points
	XBE-TN08A	TR output module 8 points (Sink type)
	XBE-TN16A	TR output module 16 points (Sink type)
	XBE-TN32A	TR output module 32 points (Sink type)
	XBE-TP08A	TR output module 8 points (Source type)
	XBE-TP16A	TR output module 16 points (Source type)
	XBE-TP32A	TR output module 32 points (Source type)
	XBE-DR16A	DC24V 8 points input/Relay 8 points output module
Modular special	XBF-AD04A	Current/Voltage input 4 channels
	XBF-DV04A	Voltage output 4 channels
	XBF-DC04A	Current output 4 channels
	XBF-RD04A	RTD input 4 channels
	XBF-TC04S	Thermocouple input 4 channels(insulated)
	XBF-AH04A	Analog input 2 channels/output 2 channels
	XBF-AD08A	Analog input 8 channels
	XBF-AD04C	Current/Voltage input 4 channels
	XBF-DV04C	Voltage output 4 channels
	XBF-DC04C	Current output 4 channels

2) Dnet

(1) Stand-alone type

Classification	Type name	Specification	
TR output	Fixed	GDL-TR2A	DC24V, TR output 16 points (Sink 0.1A)
		GDL-TR2A1	DC24V, TR output 16 points (Sink 0.5A)
		GDL-TR2B	DC24V, TR output 16 points (Source 0.5A)
		GDL-TR4A	DC24V, TR output 32 points (Sink 0.1A)
		GDL-TR4A1	DC24V, TR output 32 points (Sink 0.5A)
		GDL-TR4B	DC24V, TR output 32 points (Source 0.5A)
	Removable	GDL-TR2C	DC24V, TR output 16 points (Source 0.5A)
		GDL-TR2C1	DC24V, TR output 16 points (Sink 0.5A)
		GDL-TR4C	DC24V, TR output 32 points (Source 0.5A)
		GDL-TR4C1	DC24V, TR output 32 points (Sink 0.5A)
Hybrid	Fixed	GDL-DT4A	DC24V, DC input 16 points /TR output 16 points (Sink 0.1A)
		GDL-DT4A1	DC24V, DC input 16 points /TR output 16 points (Sink 0.5A)
		GDL-DT4B	DC24V, DC input 16 points /TR output 16 points (Source 0.5A)
	Removable	GDL-DT4C	DC24V, DC input 16 points /TR output 16 points (Source 0.5A)
		GDL-DT4C1	DC24V, DC input 16 points /TR output 16 points (Sink 0.5A)
Relay output	Fixed	GDL-RY2A	DC24V(Rating), Relay output 16 points
	Removable	GDL-RY2C	DC24V(Rating), Relay output 16 points
DC input	Fixed	GDL-D22A	DC24V(Rating), DC input 16 points
		GDL-D24A	DC24V(Rating), DC input 32 points
	Removable	GDL-D22C	DC24V(Rating), DC input 16 points
		GDL-D24C	DC24V(Rating), DC input 32 points

* Stand-alone type Dnet module can be set as General, Quick mode type and dummy mode type according to SyCon / nConfigurator (Dnet I/F communication parameter setting software) parameter setting.



(2) Modular type

When using modular type, you can change connection method from Connector connection method to Terminal connection method by using Smart Link.

Classification	Type name	Specification
Communication adapter	XDL-BSSA	Dnet I/F adapter
Modular I/O	XBE-DC08A	DC24V input module 8 points (Source/Sink type)
	XBE-DC16A/B	DC24V input module 16 points (Sink/Source type)
	XBE-DC32A	DC24V input 32 points
	XBE-RY08A/B	Relay output module 8 points
	XBE-RY16A	Relay output module 16 points
	XBE-TN08A	TR output module 8 points (Sink type)
	XBE-TN16A	TR output module 16 points (Sink type)
	XBE-TN32A	TR output module 32 points (Sink type)
	XBE-TP08A	TR output module 8 points (Source type)
	XBE-TP16A	TR output module 16 points (Source type)
	XBE-TP32A	TR output module 32 points (Source type)
	XBE-DR16A	DC24V 8 points input/Relay 8 points output module
Modular special	XBF-AD04A	Current/Voltage input 4 channels
	XBF-DV04A	Voltage output 4 channels
	XBF-DC04A	Current output 4 channels
	XBF-RD04A	RTD input 4 channels
	XBF-TC04S	Thermocouple input 4 channels(insulated)
	XBF-AH04A	Analog input 2 channels/output 2 channels

* Types of Smart Link are as follows.

Smart Link is used to change connection method from Connector connection method to Terminal connection method

Classification	Type name	Description
Terminal Board	 SLP-T40P	Change connection method from connector to terminal (For 40 pins)
Relay Board	 SLP-RY4A	Change output and connection method from TR output (NPN type), Connector to Relay output, Terminal. (For 40 pins)
Connection cable	 SLP-C101-XB	Length 1m, plastic hood type, for 40 pins
	SLP-C201-XB	Length 2m, plastic hood type, for 40 pins
	SLP-CT101-XB	Length 1m, soft tube type, for 40 pins
	SLP-CT201-XB	Length 2m, soft tube type, for 40 pins

3) Rnet

(1) Stand-alone type

Classification		Type name	Specification	
9 pin connector	Fixed	TR output	GRL-TR2A	DC24V, TR output 16 points (Sink 0.1A)
			GRL-TR4A	DC24V, TR output 32 points (Sink 0.1A)
		Hybrid	GRL-DT4A	DC24V, DC input 16/TR output 16 (Sink 0.1A)
		Relay output	GRL-RY2A	DC24V(Rating), Relay output
		DC Input	GRL-D22A	DC24V(Rating), DC input 16 points
			GRL-D24A	DC24V(Rating), DC input 32 points
5 pin connector	Fixed	TR Output	GRL-TR2A(N)	DC24V, TR output 16 points (Sink 0.1A)
			GRL-TR4A(N)	DC24V, TR output 32 points (Sink 0.1A)
		Hybrid	GRL-DT4A(N)	DC24V, DC input 16/TR output 16 (Sink 0.1A)
		Relay output	GRL-RY2A(N)	DC24V(Rating), relay output 16
		DC Input	GRL-D22A(N)	DC24V(Rating), DC input 16
			GRL-D24A(N)	DC24V(Rating), DC input 32
	Removable	TR Output	GRL-TR2C1	DC24V, TR output 16 (Sink 0.5A)
			GRL-TR2C	DC24V, TR output 16 (Source 0.5A)
			GRL-TR4C1	DC24V, TR output 32 (Sink 0.5A)
			GRL-TR4C	DC24V, TR output 32 (Source 0.5A)
		Hybrid	GRL-DT4C1	DC24V, DC input 16/TR output 16 (Sink 0.5A)
			GRL-DT4C	DC24V, DC input 16/TR output 16 (Source 0.5A)
		Relay output	GRL-RY2C	DC24V(Rating), Relay output 16
		DC Input	GRL-D22C	DC24V(Rating), DC input 16
			GRL-D24C	DC24V(Rating), DC input 32

* In case of Smart I/O Rnet Removable type Combo module, selection between Latch/Clear is available.

(2) Modular type

Classification	Type name	Specification
Communication adapter	XRL-BSSA	Rnet I/F adapter
Modular I/O	XBE-DC08A	DC24V input module 8 points (Source/Sink type)
	XBE-DC16A	DC24V input module 16 points (Sink/Source type)
	XBE-DC32A	DC24V input 32 points
	XBE-RY08A/B	Relay output module 8 points
	XBE-RY16A	Relay output module 16 points
	XBE-TN08A	TR output module 8 points (Sink type)
	XBE-TN16A	TR output module 16 points (Sink type)
	XBE-TN32A	TR output module 32 points (Sink type)
	XBE-TP08A	TR output module 8 points (Source type)
	XBE-TP16A	TR output module 16 points (Source type)
	XBE-TP32A	TR output module 32 points (Source type)
	XBE-DR16A	DC24V 8 points input/Relay 8 points output module
Modular special	XBF-AD04A	Current/Voltage input 4 channels
	XBF-DV04A	Voltage output 4 channels
	XBF-DC04A	Current output 4 channels
	XBF-RD04A	RTD input 4 channels
	XBF-TC04S	Thermocouple input 4 channels(insulated)
	XBF-AH04A	Analog input 2 channels/output 2 channels
	XBF-AD08A	Analog input 8 channels
	XBF-AD04C	Current/Voltage input 4 channels
	XBF-DV04C	Voltage output 4 channels
	XBF-DC04C	Current output 4 channels

4) Snet

(1) Stand-alone type

Classification	Type name	Specification	
TR output	Fixed	GSL-TR2A	DC24V, TR output 16 (Sink 0.1A)
		GSL-TR4A	DC24V, TR output 32 (Sink 0.1A)
Hybrid		GSL-DT4A	DC24V, DC input 16/TR output 16 (Sink 0.1A)
Relay output		GSL-RY2A	DC24V(Rating), Relay output 16
DC input		GSL-D22A	DC24V(Rating), DC input 16
		GSL-D24A	DC24V(Rating), DC input 32
TR output	Removable	GSL-TR2C	DC24V, TR output 16 (Source 0.5A)
		GSL-TR2C1	DC24V, TR output16 (Sink 0.5A)
		GSL-TR4C	DC24V, TR output 32 (Source 0.5A)
		GSL-TR4C1	DC24V, TR output 32 (Sink 0.5A)
Hybrid		GSL-DT4C	DC24V, DC input 16/TR output 16 (Source 0.5A)
		GSL-DT4C1	DC24V, DC input 16/TR output 16 (Sink 0.5A)
Relay output		GSL-RY2C	DC24V(Rating), Relay output 16
DC input		GSL-D22C	DC24V(Rating), DC input 16
		GSL-D24C	DC24V(Rating), DC input 32

5) Enet

(1) Modular type

Classification	Type name	Specification
Communication adapter	XEL-BSSA	Enet I/F adapter (Modbus/TCP)
	XEL-BSSB	Enet I/F adapter (Ethernet/IP)
Modular I/O	XBE-DC08A	DC24V input module 8 points (Source/Sink type)
	XBE-DC16A	DC24V input module 16 points (Sink/Source type)
	XBE-DC32A	DC24V input 32 points
	XBE-RY08A/B	Relay output module 8 points
	XBE-RY16A	Relay output module 16 points
	XBE-TN08A	TR output module 8 points (Sink type)
	XBE-TN16A	TR output module 16 points (Sink type)
	XBE-TN32A	TR output module 32 points (Sink type)
	XBE-TP08A	TR output module 8 points (Source type)
	XBE-TP16A	TR output module 16 points (Source type)
	XBE-TP32A	TR output module 32 points (Source type)
	XBE-DR16A	DC24V 8 points input/Relay 8 points output module
Modular special	XBF-AD04A	Current/Voltage input 4 channels
	XBF-DV04A	Voltage output 4 channels
	XBF-DC04A	Current output 4 channels
	XBF-RD04A	RTD input 4 channels
	XBF-TC04S	Thermocouple input 4 channels(insulated)
	XBF-AH04A	Analog input 2 channels/output 2 channels
	XBF-AD08A	Analog input 8 channels
	XBF-AD04C	Current/Voltage input 4 channels
	XBF-DV04C	Voltage output 4 channels
XBF-DC04C	Current output 4 channels	

6) RAPIenet

(1) Stand-alone type

Classification	Type name	Specification
TR output	GEL-TR4C1	DC24V, TR output 32 (Sink 0.5A)
Hybrid	GEL-DT4C1	DC24V, DC input 16/TR output 16 (Sink 0.5A)
Relay output	GEL-RY2C	DC24V(Rating), Relay output 16
DC input	GEL-D24C	DC24V(Rating), DC input 32
Analog input	GEL-AV8C	Analog voltage input, 8 channels
	GEL-AC8C	Analog current input, 8 channels
Analog output	GEL-DV4C	Analog voltage output, 4 channels
	GEL-DC4C	Analog current output, 4 channels

1.3.3 Compatibility list according to Smart I/O module version

The following table indicates compatible list of O/S Version between each CPU and master module to use Smart I/O series. Before applying the system, refer to the following list.
In case of XGK/XGI/XGB, all versions are available.

Classification		Available Module		Ref.
		Type	O/S Version	
CPU	GM3	GM3-CPUA	Version 2.5 or later	
	GM4	GM4-CPUA/B/C	Version 2.6 or later	
	GM6	GM6-CPUA/B/C	Version 1.9 or later	
	GM7	G7M Series	Version 1.6 or later	
	K1000S	K7P-30AS	Version 3.1 or later	
	K300S	K4P-15AS	Version 3.1 or later	
	K200S	K3P-03AS/BS/CS	Version 2.2 or later	
	K80S	K7M Series	Version 1.6 or later	
PADT	GMWIN		Version 3.6 or later	
	KGLWIN		Version 3.3 or later	
	XG5000		Version 4.07 or later	
Communication Master	Pnet	G3/4/6L-PUEA/B	Version 1.0 or later	
	Dnet	G4/6L-DUEA	Version 1.2 or later	
	Rnet	G3/4/6/7L-RUEA	Version 1.0 or later	
	Modbus	G3/4/6L-CUEA	Version 2.0 or later	can be used as built-in at GM7/K80S
	RAPIenet	XGL-EIMT/F/H	Version 3.0 or later	

* Smart I/O Snet can be used by using Cnet module at GM3/4/6, K1000S/300S/200S and can be used as built-in at GM7/K80S

The following table indicates available Smart I/O master module for each CPU

Classification		Available Smart I/O master module					Ref.
		CPU	Pnet	Dnet	Rnet	Snet	
CPU	GM3	GM3-CPUA	○	-	○	○	
	GM4	GM4-CPUA/B/C	○	○	○	○	
	GM6	GM6-CPUA/B/C	○	○	○	○	
	GM7	G7M Series	-	-	○	○	
	K1000S	K7P-30AS	○	-	○	○	
	K300S	K4P-15AS	○	○	○	○	
	K200S	K3P-03AS/BS/CS	○	○	○	○	
	K80S	K7M Series	-	-	○	○	
	XGK	XGL-CPUH/CPUS	○	○	○	○	
		XGL-CPUA/CPUE	○	○	○	○	
	XGI	XGI-CPUU	○	○	○	○	
	XGR	XGR-CPUH/T	○	○	○	○	Note1)
		XGR-CPUH/F	○	○	○	○	
XGB	XGB-XBMS	-	-	-	○		

Note 1) In case of XGR system, master communication module can be installed on extension base.

1.4 Notice in Using

When installing this device, notice the followings for the reliability and safety.

Category	Classification	Contents
Temperature	Condition	<ul style="list-style-type: none"> • When installing this device, maintain the temperature between 0~55 °C • Do not exposure it to direct light.
	Measure	<ul style="list-style-type: none"> • When temperature is too high, install fan, air-conditioner and when temperature is too low, install suitable device.
Condensing	Condition	<ul style="list-style-type: none"> • No condensing allowed. • Install something in the control panel for protection from the water and dust.
	Measure	<ul style="list-style-type: none"> • Due to the frequent On/Off, condensing may occur. In this case, turn on the device at the night
Shock	Condition	<ul style="list-style-type: none"> • Install it in the place where impact and vibration don't occur..
	Measure	<ul style="list-style-type: none"> • When impact and vibration is severe, install anti-vibration rubber so that vibration and impact doesn't affect the device.
Gas	Condition	<ul style="list-style-type: none"> • Install in the place where there is not corrosive gas.
	Measure	<ul style="list-style-type: none"> • When corrosive gas enters, plan air-purification measure in the control panel.
EMC Environment	Condition	<ul style="list-style-type: none"> • Install in the place where electro-magnetic wave is not severe.
	Measure	<ul style="list-style-type: none"> • In case of wiring, set the precise route. • Check the shield of control panel <p>For light, use glow lamp and avoid fluorescent lamp</p> <ul style="list-style-type: none"> • When installing power module, ground the device at standard electric potential

Chapter 2 Product Specification

2.1 General Specification

The General Specification of Smart I/O series is as follows.

No	Items	Specification	References			
1	Operating temperature	0 ~ 55 °C	-			
2	Storage temperature	-25 ~ +70 °C	-			
3	Operating humidity	5 ~ 95%RH, no dew	-			
4	Storage humidity	5 ~ 95%RH, no dew	-			
5	Vibration	In case of Intermittent vibration			-	IEC6 1131-2
		Frequency	Acceleration	Amplitude	Times	
		5 ≤ f < 8.4Hz	-	3.5mm	X, Y, Z 10 times each direction	
		8.4 ≤ f ≤ 150Hz	9.8m/s ² {1G}	-		
		In case of Continuous vibration				
		Frequency	Acceleration	Amplitude		
5 ≤ f < 8.4Hz	-	1.75mm				
8.4 ≤ f ≤ 150Hz	4.9m/s ² {0.5G}	-				
6	shocks	<ul style="list-style-type: none"> max. impact acceleration : 147 m/s²{15G} Application time : 11ms pulse wave type : semi-sine wave pulse (3 times each direction X, Y, Z) 	IEC 61131-2			
7	Noise	Square wave impulse noise	DC: ± 900 V			LS ELECTRIC Standard
		Electrostatic discharging	Voltage : 4kV (contact discharging)			IEC 61131-2, IEC 61000-4-2
		Radiant electromagnetic field noise	80 ~ 1000 MHz, 10 V/m			IEC 61131-2, IEC 61000-4-2
		Fast Transient / Bust Noise	Classification	Power module	Digital I/O (more than 24V)	Digital I/O (below 24V) Analog I/O Communication Interface
		Voltage	2kV	1kV	0.25kV	
8	Ambient conditions	No corrosive gas, no dust	-			
9	operating altitude	Less than 2,000m	-			
10	Pollution degree	Less than 2	-			
11	Cooling method	Natural air-conditioning	-			

Notes

- 1) IEC (International Electro-technical Commission)
: International civil community that promotes international cooperation for standardization of electric/electro technology, publishes international standard and operates suitability assessment system related to the above.
- 2) Pollution Degree
: An index that indicates the pollution degree of used environment that determines the insulation performance of the device. For example, pollution degree 2 means the state to occur the pollution of non-electric conductivity generally, but the state to occur temporary electric conduction according to the formation of dew.

2.2 Power Specification

2.2.1 Performance specification

Here describes the Power Specification of Smart I/O

1) Stand-alone type module

Category	Specification
	Pnet, Rnet, Modbus, Dnet, RAPIEnet
Input voltage	DC 24V (Tolerance range: DC 20.4V ~ 28.8V)
Input current	0.5A (+24 VDC)
Inrush current	40A lower: (24 VDC Input)
Power indication	When Power is on, LED ON
Cable specification	1.5 ~ 2.5mm ² (AWG 16 ~ 22)
Fastening torque	12kg · cm

2) Modular type module

Category	Specification
	Pnet, Dnet, Rnet, Enet
Input voltage/current	DC24V/0.55A (allowed range:DC19.2V ~ 28.8V) In case of Dnet, it is available to operate in 11V.
Output voltage/current	5V (± 20%) / less than 1.5A
Inrush current	Max 10A
Power indication	When power is On, LED ON

* In order to protect power supplier, use the max. 4A fuse-equipped power supplier.

Consumption current of I/O module available to equip is as follows.

Expansion module		Type name	Consumption current (mA)	Available Smart I/O
I/O module	Input module	XBE-DC08A	30	Dnet, Rnet, Pnet, Enet
		XBE-DC16A/B	40	
		XBE-DC32A	50	
	Output module	XBE-RY08A/B	240	
		XBE-RY16A	420	
		XBE-TN08A	40	
		XBE-TN16A	60	
		XBE-TN32A	120	
		XBE-TP08A	40	
		XBE-TP16A	50	
		XBE-TP32A	80	
		I/O module	XBE-DR16A	
Special module	XBF-AD04A	120	Dnet, Rnet, Pnet, Enet	
	XBF-DC04A	110		
	XBF-DV04A	110		
	XBF-RD04A	100		
	XBF-TC04S	100		
	XBF-AH04A	120	Rnet,Pnet,Enet	
	XBF-AD08A	105	Rnet,Pnet,Enet	
	XBF-AD04C	105	Rnet,Pnet,Enet	
	XBF-DV04C	75	Rnet,Pnet,Enet	
	XBF-DC04C	75	Rnet,Pnet,Enet	

2.3 Digital Input Module Specification

2.3.1 DC16 points stand-alone type input module (Source/Sink)

Type name		DC Input Module
Specification		
Input point		16 points
Insulation method		Photo-coupler insulation
Rated input voltage		DC24V
Rated input current		7 mA(fixed), 5mA(removable)
Voltage range		DC20.4 ~ 28.8V (ripple rate : within 5%)
Max. simultaneous input point		100% (16 points/1COM) simultaneously ON
ON voltage / ON current		More than DC19V / more than 3.5 mA
OFF voltage / OFF current		Less than DC6V / less than 1.5 mA
Input resistance		Approx. 3.3 kΩ(fixed), 4.7 kΩ(removable)
Response time	Off → On	Less than 3 ms
	On → Off	Less than 3 ms
Common method		16 points / COM (Sink/Source Type)
Internal consumption current		Less than 70mA
Operation indication		LED ON when input ON
External connection method		Terminal unit connector (M3 X 6 screws)
Weight		Less than 160g/190g (D22A: Fixed /D22C: Removable)

Circuit Configuration

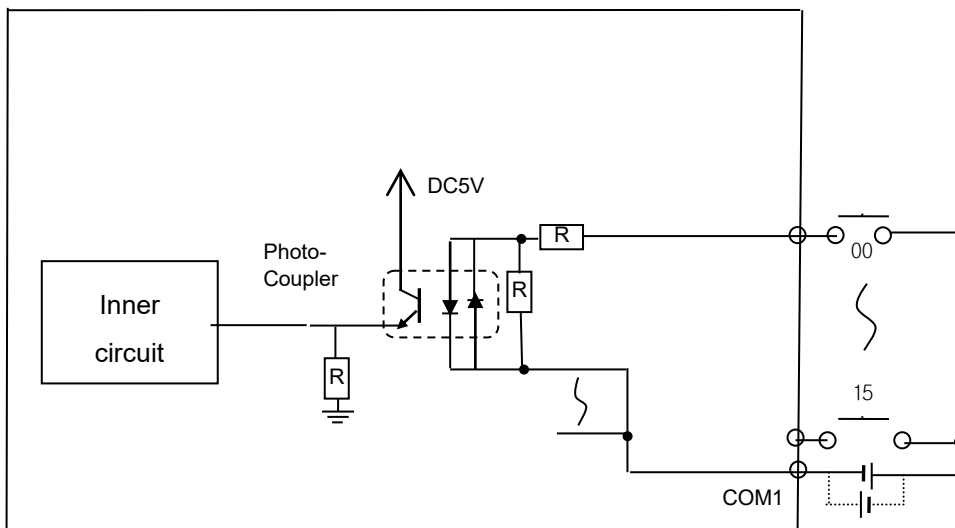

2.3.2 DC32 point stand-alone type input module (Source/Sink)

Type name		DC Input Module
Specification		
Input point	32 points	
Insulation method	Photo-coupler insulation	
Rated input voltage	DC24V	
Rated input current	7 mA(fixed), 5mA(removable)	
Use voltage range	DC20.4 ~ 28.8V (ripple rate : within 5%)	
Max. simultaneous input point	100% (16 points/1COM) simultaneously ON	
ON voltage / ON current	More than DC19V / more than 3.5 mA	
OFF voltage / OFF current	Less than DC6V / less than 1.5 mA	
Input resistance	Approx. 3.3 kΩ(fixed), 4.7 kΩ(removable)	
Response time	Off -> On	Less than 3 ms
	On -> Off	Less than 3 ms
Common method	16 points / COM (Source/Sink type)	
Internal consumption current	Less than 300 mA	
Operation indication	LED ON when input ON	
External connection method	Terminal unit connector (M3 X 6 screws)	
Weight	Less than 240g/270g (D24A: Fixed / D24C: Removable)	

Circuit

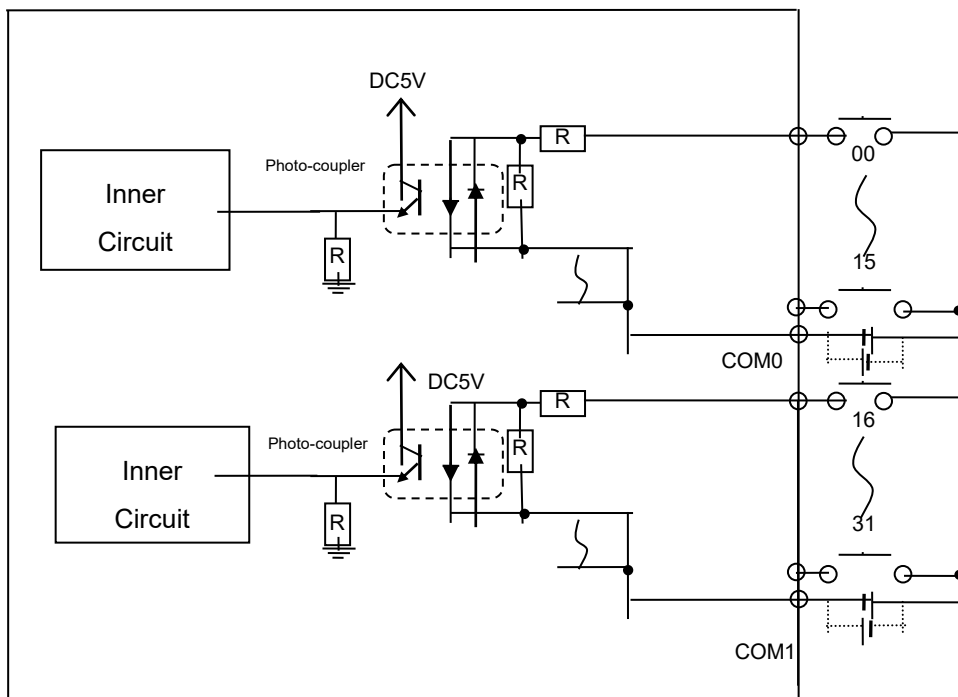

2.3.3 DC 8 point modular type input module (Source/Sink)

Type name		DC Input Module		
Specification		XBE-DC08A		
Input point		8 point		
Insulation method		Photo-coupler insulation		
Rated input voltage		DC24V		
Rated input current		About 4 mA		
Use voltage range		DC20.4~28.8V (ripple rate less than 5%)		
ON voltage / ON current		More than DC19V / more than 3 mA		
OFF voltage / OFF current		Less than DC6V / less than 1 mA		
Input resistance		Approx. 5.6 kΩ		
Response time	Off → On	1/3/5/10/20/70/100 ms(setting as CPU parameter) initial value: 3 ms		
	On → Off			
Insulation pressure		AC560Vrms / 3Cycle (altitude 2000m)		
Insulation resistor		With insulation resistor meter more than 10 MΩ		
Common method		8point / COM		
Suitable wire size		Stranded wire 0.3~0.75 mm ² (external size less than 2.8 mm)		
Internal consumption current		30 mA (When all input point is On)		
Operation indication		LED On when input is On		
External connection method		9 pin terminal connector		
Weight		52g		
Circuit configuration		No.	Point	Type
<p>Terminal No.</p>		TB1	0	
		TB2	1	
		TB3	2	
		TB4	3	
		TB5	4	
		TB6	5	
		TB7	6	
		TB8	7	
		TB9	COM	

2.3.4 DC 16 point modular type input module (Sink/Source)

Type name		DC input module		
		XBE-DC16A	XBE-DC16B	
Specification				
Input point		16point		
Insulation method		Photo-coupler insulation		
Rated input voltage		DC24V	DC12V, DC24V	
Rated input current		About 4 mA	About 4mA, 8 mA	
Usage voltage range		DC20.4~28.8V (ripple rate less than 5%)	DC9.5~30V (ripple rate less than 5%)	
On voltage / On current		More than DC19V / more than 3 mA	More than DC9V / more than 3mA	
Off voltage / Off current		Less than DC6V / less than 1 mA	Less than DC5V / less than 1mA	
Input resistance		About 5.6 kΩ	About 2.7 kΩ	
Response time	Off → On	1/3/5/10/20/70/100 ms(setting with CPU parameter) initial value:3 ms		
	On → Off			
Insulation pressure		AC560Vrms / 3Cycle (altitude 2000m)		
Insulation resistor		With insulation resistor meter more than 10 MΩ		
Common method		16 point / COM		
Suitable wire size		Stranded wire 0.3~0.75 mm ² (external less than 2.8 mm)		
Inner consumption current		40 mA (When input point is On)		
Operating indication		LED is On when input is On		
External connection method		8 pin terminal unit connector + 10 pin terminal unit connector		
Weight		53g		
Circuit configuration				
		No.	Point	type
		TB1	0	
		TB2	1	
		TB3	2	
		TB4	3	
		TB5	4	
		TB6	5	
		TB7	6	
		TB8	7	
		TB1	8	
		TB2	9	
		TB3	A	
		TB4	B	
		TB5	C	
		TB6	D	
		TB7	E	
		TB8	F	
		TB9	COM	
		TB10	COM	

2.3.5 DC 32 point modular type input module (Source/Sink)

Type name		DC Input Module
Specification		XBE-DC32A
Input point		32point
Insulation method		Photo-coupler insulation
Rated input voltage		DC24V
Rated input current		About 4 mA
Usage voltage range		DC20.4~28.8V (ripple rate less than 5%)
Input derating		Refer to the following derating diagram
On voltage / On current		More than DC19V / more than 3 mA
Off voltage / Off current		Less than DC6V / Less than 1 mA
Input resistance		About 5.6 kΩ
Response time	Off → On	1/3/5/10/20/70/100 ms(setting with CPU parameter) initial value:3 ms
	On → Off	
Insulation pressure		AC560Vrms / 3Cycle (altitude 2000m)
Insulation resistor		With resistor meter more than 10 MΩ
Common method		32 point / COM
Suitable wire size		0.3 mm ²
Inner consumption current		50 mA (When input point is On)
Operation indication		LED flicker when input is On
External connection method		40 pin connector
weight		60g

Circuit configuration	No.	Point	No.	Point	type
	B20	00	A20	10	
	B19	01	A19	11	
B18	02	A18	12		
B17	03	A17	13		
B16	04	A16	14		
B15	05	A15	15		
B14	06	A14	16		
B13	07	A13	17		
B12	08	A12	18		
B11	09	A11	19		
B10	0A	A10	1A		
B09	0B	A09	1B		
B08	0C	A08	1C		
B07	0D	A07	1D		
B06	0E	A06	1E		
B05	0F	A05	1F		
B04	NC	A04	NC		
B03	NC	A03	NC		
B02	COM	A02	COM		
B01	COM	A01	COM		

Input derating diagram

Temp. (°C)	Current (mA)
0	4
45	4
55	0

2.4 Digital Output Module Specification

2.4.1 16 point relay output stand-alone type module

Type name		Relay Output Module
Specification		
Output point		16 points
Insulation method		Relay insulation
Rating (Resistive Load)	Max. rated load	3A 250VAC, 3A 30VDC
	Max. rated power	750VA, 90W
	Max. rated load voltage	250VAC, 110VDC
	Max. rated load current	5A
Max. open/close frequency		1,200 times / hr
Surge killer		None
Life	Mechanical	2X10 ⁷
	Electrical (20cpm base)	10 ⁵
Response time	Off → On	Less than 10 ms
	On → Off	Less than 12 ms
Common method		8 points / COM
Internal consumption current		Less than 325mA (when all points ON)
Operation indication		LED ON when output ON
External connection method		Terminal unit connector (M3 X 6 screws)
Weight		Less than 300g/330g (RY2A: fixed / RY2C:removable)

Circuit Configuration

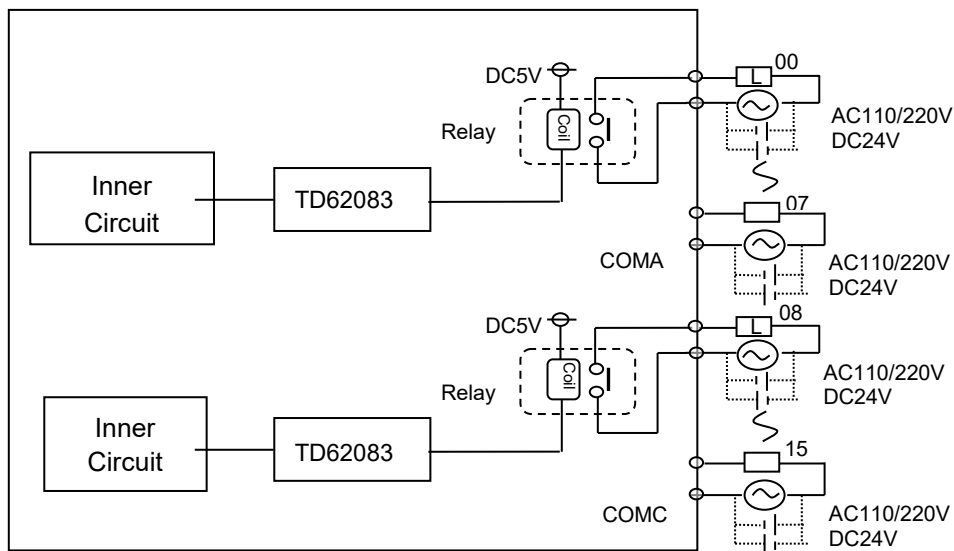

2.4.2 16 point transistor stand-alone type output module (0.1 Sink)

Type name		Transistor Output Module
Specification		
Output point		16 points
Insulation method		Photo-coupler insulation
Rated load voltage		DC 24V
Load voltage range		DC 20.4 ~ 26.4V
Max. load current		0.1A / 1point, 2A / 1COM
Leakage current when OFF		Less than 0.1mA
Max. inrush current		Less than 0.4A/10ms
Max. voltage falling when ON		DC 1.5V
Response time	Off → On	Less than 2 ms
	On → Off	Less than 2 ms
Common method		16 points / 1COM
Internal consumption current		Less than 80 mA (when all points ON)
External power Supply	Voltage	DC24V ± 10% (ripple voltage : less than 4 Vp-p)
	current	Less than 50 mA (DC24V per 1COM)
Operation indication		LED ON when output ON
External connection method		Terminal unit connector (M3 X 6 screws)
Weight		Less than 160g (fixed type)

Circuit Configuration

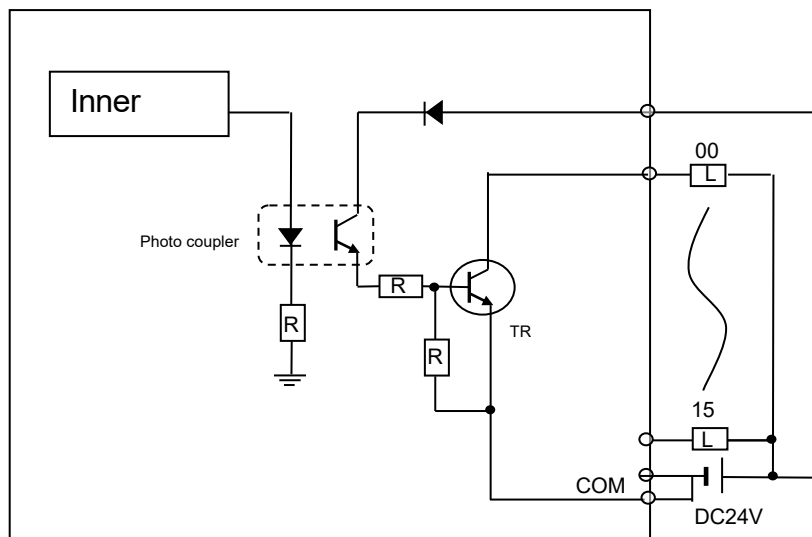

2.4.3 16 point transistor stand-alone type output module (0.5A Sink)

Type name		Transistor Output Module
Specification		
Output point	16 point	
Insulation method	Photo-coupler insulation	
Rated load voltage	DC 24V	
Load voltage range	DC 20.4 ~ 26.4V	
Max. load current	0.5A / 1 point, 3A / 1COM	
Leakage current when Off	Less than 0.1mA	
Max. inrush current	Less than 1A / 10 ms	
Max. voltage falling when ON	DC 1.5V	
Response time	Off → On	Less than 2 ms
	On → Off	Less than 2 ms
Common method	16 point / 1COM (sink type)	
Internal consumption current	Less than 90 mA (when all points ON)	
External power Supply	Voltage	DC24V ± 10% (ripple voltage : less than 4 Vp-p)
	Current	Less than 50 mA (DC24V per 1COM)
Operation indication	LED ON when output ON	
External connection method	Terminal unit connector (M3 X 6 screws)	
Weight	Less than 160g/190g (TR2A1:Fixed / TR2C1:Removable)	

Circuit Configuration

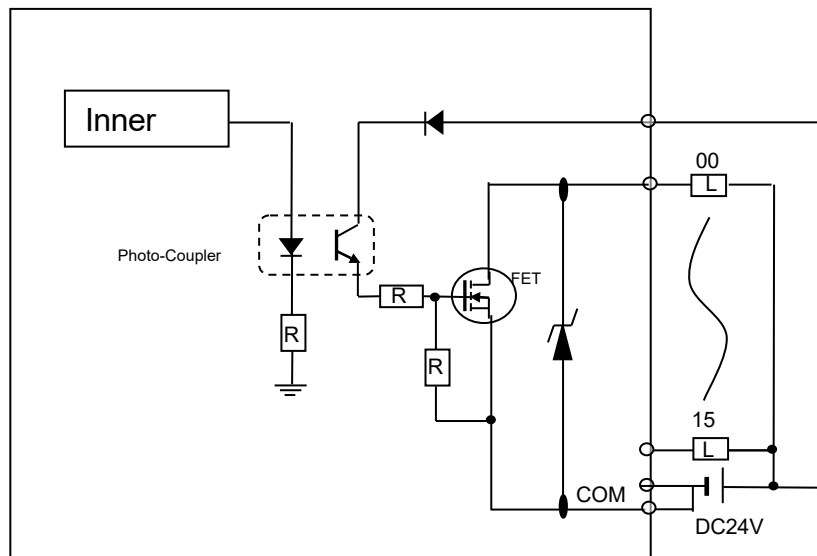

2.4.4 16 point transistor stand-alone type output module (0.5A Source)

Type name		Transistor Output Module
Specification		
Output point		16 point
Insulation method		Photo-coupler insulation
Rated load voltage		DC 24V
Load voltage range		DC 20.4 ~ 26.4V
Max. load current		0.5A / 1 point, 3A / 1COM
Leakage current when Off		Less than 0.1mA
Max. inrush current		Less than 1A / 10 ms
Max. voltage falling when ON		DC 1.5V
Response time	Off → On	Less than 2 ms
	On → Off	Less than 2 ms
Common method		16point / 1COM (sink type)
Internal consumption current		Less than 90 mA (when all points ON)
External power Supply	Voltage	DC24V ± 10% (ripple voltage : less than 4 Vp-p)
	Current	Less than 50 mA (DC24V per 1COM)
Operation indication		LED ON when output ON
External connection method		Terminal unit connector (M3 X 6 screws)
Weight		Less than 161g/191g (TR2A1:Fixed / TR2C1:Removable)

Circuit Configuration

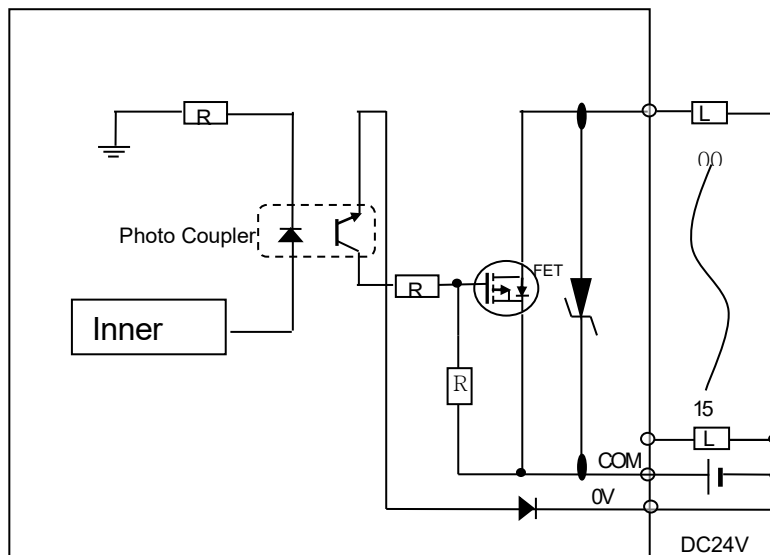

2.4.5 32 point Transistor stand-alone type output module (0.1A Sink)

Type Name		Transistor Output Module
Specification		
Output point		32 point
Insulation method		Photo-coupler insulation
Rated load voltage		DC 24V
Load voltage range		DC 20.4 ~ 26.4V
Max. load current		0.1A / 1 point, 2A / 1COM
Leakage current when Off		Less than 0.1 mA
Max. inrush current		Less than 0.4 A / 10 ms
Max. voltage falling when ON		DC 1.0 V
Response time	Off → On	Less than 2 ms
	On → Off	Less than 2 ms
Common method		16 point / 1 COM(Sink Type)
Internal consumption current		Less than 110 mA (when all points ON)
External power Supply	Voltage	DC24V ± 10% (ripple voltage : less than 4 Vp-p)
	Current	Less than 40 mA (DC24V per 1COM)
Operation indication		LED ON when output ON (16 point indication conversion by using select switch)
External connection method		Terminal unit connector (M3 X 6 screws)
Weight		Less than 240g (Fixed type)

Circuit configuration

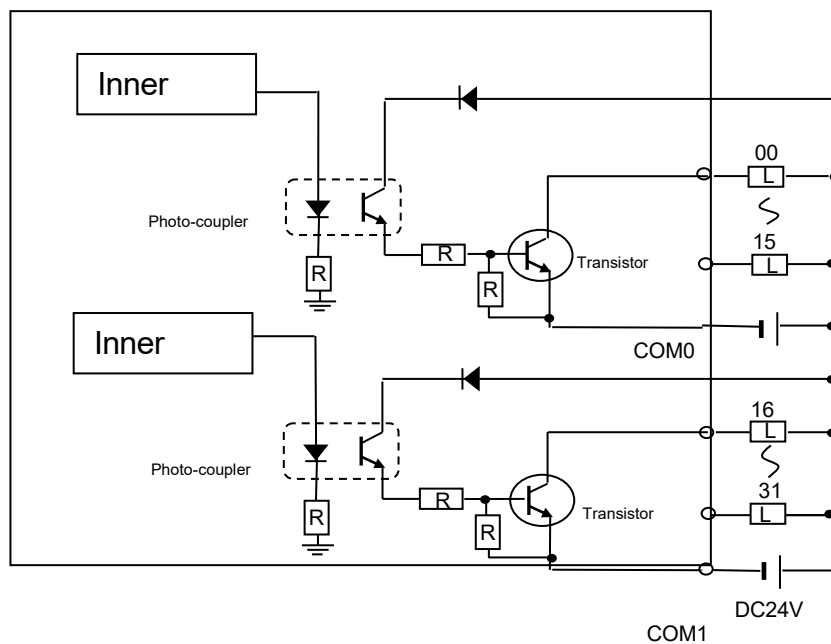

2.4.6 32 point transistor stand-alone type output module (0.5A Source)

Type Name		Transistor Output Module
Specification		
Output point		32 point
Insulation method		Photo-coupler insulation
Rated load voltage		DC 24V
Load voltage range		DC 20.4 ~ 26.4V
Max. load current		0.5A / 1point, 3A / 1COM
Leakage current when Off		Less than 0.1 mA
Max. inrush current		Less than 1A / 10 ms
Max. voltage falling when ON		DC 1.0 V
Response time	Off → On	Less than 2 ms
	On → Off	Less than 2 ms
Common method		16 point / 1 COM (Sink Type)
Internal consumption current		Less than 270 mA (when all points ON)
External power Supply	Voltage	DC24V ± 10% (ripple voltage : less than 4 Vp-p)
	Current	Less than 40 mA (DC24V per 1COM)
Operation indication		LED ON when output ON (16 point indication conversion by using select switch)
External connection method		Terminal unit connector (M3 X 6 screws)
Weight		Less than 240g/290g (TR4B:fixed / TR4C: removable)

Circuit configuration

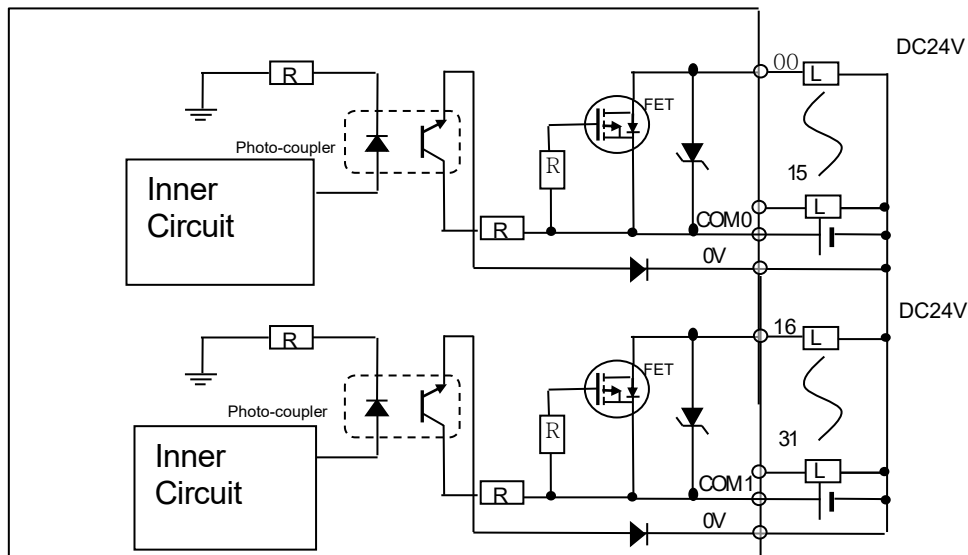

2.4.7 32 Transistor stand-alone type Output Module (0.5A Sink)

Type Name		Transistor Output Module
Specification		
Output point		32 point
Insulation method		Photo-coupler insulation
Rated load voltage		DC 24V
Range of load voltage		DC 20.4 ~ 26.4V
Max. load current		0.5A / 1point, 3A / 1COM
Leakage current when Off		Less than 0.1 mA
Max. inrush current		Less than 1A / 10 ms
Max. voltage falling when ON		DC 1.0 V
Response time	Off → On	Less than 2 ms
	On → Off	Less than 2 ms
Common method		16 point / 1 COM (Sink Type)
Internal consumption current		Less than 270 mA (when all points ON)
External power Supply	Voltage	DC24V ± 10% (ripple voltage : less than 4 Vp-p)
	Current	Less than 40 mA (DC24V per 1COM)
Operation indication		LED ON when output ON (16 point indication conversion by using select switch)
External connection method		Terminal unit connector (M3 X 6 screws)
Weight		Less than 240g/290g (TR4A1:Fixed / TR4C1:Removable)

Circuit Configuration

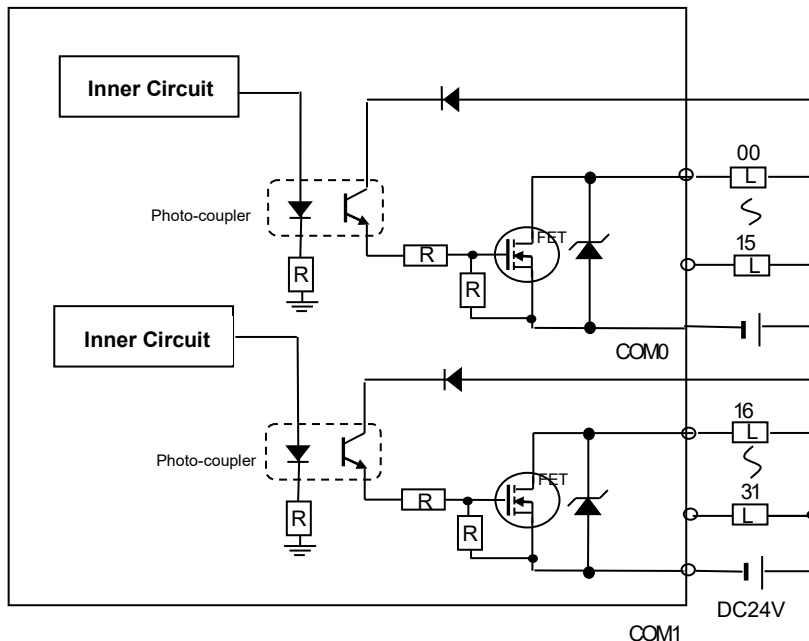

2.4.8 8 point relay modular type output module

Type name		Relay Output Module		
Specification		XBE-RY08A		
Output point	8 point			
Insulation method	Relay insulation			
Rated load voltage / current	DC24V 2A(resistor load) / AC220V 2A(COSΨ = 1), 5A/COM			
Min. load voltage / current	DC5V / 1 mA			
Max. load voltage	AC250V, DC125V			
Leakage current when OFF	0.1 mA (AC220V, 60 Hz)			
Max. open/close frequency	More than 3,600 times / hr			
Surge killer	None			
Life	Mechanical	More than 2X10 ⁷		
	Electrical	Rated load voltage / current more than 100,000		
		AC200V / 1.5A, AC240V / 1A (COSΨ = 0.7) more than 100,000		
		AC200V / 1A, AC240V / 0.5A (COSΨ = 0.35) more than 100,000		
Response time	Off → On	Less than 10 ms		
	On → Off	Less than 12 ms		
Common method	8 point / COM			
Suitable wire size	Stranded wire 0.3~0.75 mm ² (external radius less than 2.8 mm)			
Internal consumption current	230 mA (When output point On)			
Operation indication	LED On when output is On			
External connection method	9 pin terminal connector			
Weight	80g			
Circuit configuration		No.	Point	Shape
		TB1	0	
		TB2	1	
		TB3	2	
		TB4	3	
		TB5	4	
		TB6	5	
		TB7	6	
		TB8	7	
		TB9	COM	

2.4.9 8 point relay modular type output module (B type)

Type name		Relay Output Module		
Specification		XBE-RY08B		
Output point		1 point		
Insulation method		Relay insulation		
Rated load voltage / current		DC24V 2A(resistor load) / AC220V 2A(COSΨ = 1), 2A/COM		
Min. load voltage / current		DC5V / 1 mA		
Max. load voltage		AC250V, DC125V		
Leakage current when OFF		0.1 mA (AC220V, 60 Hz)		
Max. open/close frequency		More than 3,600 times / hr		
Surge killer		None		
Life	Mechanical	More than 2X10 ⁷		
	Electrical	Rated load voltage / current more than 100,000		
		AC200V / 1.5A, AC240V / 1A (COSΨ = 0.7) more than 100,000		
		AC200V / 1A, AC240V / 0.5A (COSΨ = 0.35) more than 100,000		
		DC24V / 1A, DC100V / 0.1A (L / R = 7 ms) more than 100,000		
Response time	Off → On	Less than 10 ms		
	On → Off	Less than 12 ms		
Common method		1 point / COM		
Suitable wire size		Stranded wire 0.3~0.75 mm ² (external radius less than 2.8 mm)		
Internal consumption current		230 mA (When output point On)		
Operation indication		LED On when output is On		
External connection method		9 pin terminal connector x 2ea		
Weight		81g		
Circuit configuration		No.	Point	Shape
		TB1	0	
		TB2	COM0	
		TB3	1	
		TB4	COM1	
		TB5	2	
		TB6	COM2	
		TB7	3	
		TB8	COM3	
		TB9	NC	
		TB1	4	
		TB2	COM4	
		TB3	5	
		TB4	COM5	
		TB5	6	
		TB6	COM6	
		TB7	7	
		TB8	COM7	
		TB9	NC	

2.4.10 16 point relay modular type output module

Type name		Relay Output Module		
		XBE-RY16A		
Specification				
Output point		16 points		
Insulation method		Relay insulation		
Rated load voltage / current		DC24V 2A(resistor load) / AC220V 2A(COSΨ = 1), 5A/COM		
Min. load voltage / current		DC5V / 1 mA		
Max. load voltage		AC250V, DC125V		
Leakage current when OFF		0.1 mA (AC220V, 60 Hz)		
Max. open/close frequency		More than 3,600 times / hr		
Surge killer		None		
Life	Mechanical	More than 2X10 ⁷		
	Electrical	Rated load voltage / current more than 1X10 ⁵		
		AC200V / 1.5A, AC240V / 1A (COSΨ = 0.7) more than 100,000		
		AC200V / 1A, AC240V / 0.5A (COSΨ = 0.35) more than 100,000		
		DC24V / 1A, DC100V / 0.1A (L / R = 7 ms) more than 100,000		
Response time	Off → On	Less than 10 ms		
	On → Off	Less than 12 ms		
Common method		8 point / COM		
Suitable wire size		Stranded wire 0.3~0.75 mm ² (external radius less than 2.8 mm)		
Internal consumption current		440 mA (When output point On)		
Operation indication		LED On when output is On		
External connection method		9 pin terminal connector x 2ea		
Weight		130g		
Circuit configuration		No.	Point	Shape
		TB1	0	
		TB2	1	
		TB3	2	
		TB4	3	
		TB5	4	
		TB6	5	
		TB7	6	
		TB8	7	
		TB9	COM	
		TB1	8	
		TB2	9	
		TB3	A	
		TB4	B	
		TB5	C	
		TB6	D	
		TB7	E	
		TB8	F	
		TB9	COM	

2.4.11 8 point Transistor Modular type Output Module (0.5 A Sink)

Type name		Transistor output module		
Specification		XBE-TN08A		
Output point		8point		
Insulation method		Photo-coupler insulation		
Rated load voltage		DC 12V, DC24V		
Load voltage range		DC 10.2 ~ 26.4V		
Max. load current		0.5A / 1point		
Leakage current when Off		Less than 0.1 mA		
Max. inrush current		Less than 4A / 10 ms		
Max. voltage drop when On		Less than DC 0.4V		
Surge killer		Zenner diode		
Response time	Off → On	Less than 1 ms		
	On → Off	Less than 1 ms (rated load, resistor load)		
Common method		8point / COM		
Suitable wire size		Stranded wire 0.3~0.75 mm ² (external radius less than 2.8 mm)		
Internal consumption current		240 mA (When output point is On)		
External supply power	Voltage	DC12V, DC24V ± 10% (Ripple voltage less than 4 Vp-p)		
	Current	Less than 10 mA (When connecting DC24V)		
Operation indication		LED On when output is On		
External connection method		10 pin terminal connector		
Weight		70g		
Circuit configuration		No.	Point	Shape
		TB01	0	
		TB02	1	
		TB03	2	
		TB04	3	
		TB05	4	
		TB06	5	
		TB07	6	
		TB08	7	
		TB09	DC12 /24V	
		TB10	COM	

2.4.12 16 point Transistor Modular type Output Module (0.5 A Sink)

Type name		Transistor output module		
Specification		XBE-TN16A		
Output point		16 point		
Insulation method		Photo-coupler insulation		
Rated load voltage		DC12V, DC24V		
Load voltage range		DC 10.2 ~ 26.4V		
Max. load current		0.5A / 1 point, 2A / 1COM		
Leakage current when Off		Less than 0.1 mA		
Max. inrush current		Less than 4A / 10 ms		
Max. voltage drop when On		Less than DC 0.4V		
Surge killer		Zenner diode		
Response time	Off → On	Less than 1 ms		
	On → Off	Less than 1 ms (rated load, resistor load)		
Common method		16point / COM		
Suitable wire size		Stranded wire 0.3~0.75 mm ² (external radius less than 2.8 mm)		
Internal consumption current		50 mA (When output point is On)		
External supply power	Voltage	DC12V, DC24V ± 10% (Ripple voltage less than 4 Vp-p)		
	Current	Less than 10 mA (when connecting DC24V)		
Operation indication		LED On when output is On		
External connection method		8 pin terminal connector + 10 pin terminal connector		
Weight		50g		
Circuit configuration		No.	Point	Shape
		TB01	0	
		TB02	1	
		TB03	2	
		TB04	3	
		TB05	4	
		TB06	5	
		TB07	6	
		TB08	7	
		TB01	8	
		TB02	9	
TB03	A			
TB04	B			
TB05	C			
TB06	D			
TB07	E			
TB08	F			
TB09	DC12 /24V			
TB10	COM			

2.4.13 32 point Transistor Modular type Output Module (0.2 A Sink)

Type name		Transistor output module				
Specification		XBE-TN32A				
Output point		32 point				
Insulation method		Photo-coupler insulation				
Rated load voltage		DC12V, DC24V				
Load voltage range		DC 10.2 ~ 26.4V				
Max. load current		0.2A / 1point, 2A / 1COM				
Leakage current when Off		Less than 0.1 mA				
Max. inrush current		Less than 0.7A / 10 ms				
Max. voltage drop when On		Less than DC 0.4V				
Surge killer		Zener diode				
Response time	Off → On	Less than 1 ms				
	On → Off	Less than 1 ms (Rated load, resistor load)				
Common method		32 point / COM				
Suitable wire size		0.3 mm ²				
Internal consumption current		80 mA (When output point is On)				
External supply power	Voltage	DC12V, DC24V ± 10% (Ripple voltage less than 4 Vp-p)				
	Current	Less than 20 mA (When connecting DC24V)				
Operation indication		LED On when output is On				
External connection method		40 pin connector				
Weight		60g				
Circuit configuration		No.	point	No.	point	Shape
		B20	00	A20	10	
		B19	01	A19	11	
		B18	02	A18	12	
		B17	03	A17	13	
		B16	04	A16	14	
		B15	05	A15	15	
		B14	06	A14	16	
		B13	07	A13	17	
		B12	08	A12	18	
		B11	09	A11	19	
		B10	0A	A10	1A	
		B09	0B	A09	1B	
		B08	0C	A08	1C	
		B07	0D	A07	1D	
		B06	0E	A06	1E	
		B05	0F	A05	1F	
		B04	NC	A04	NC	
B03	NC	A03	NC			
B02	DC12 /24V	A02	COM			
B01		A01				

2.5 Digital I/O Combo Module Specification

2.5.1 32 point I/O combo module (DC 16/TR16 point)

I/O combo module			
Input		Output (TR 0.1A Sink)	
Input point	16 points	Output point	16 points
Insulation method	Photo-coupler insulation	Insulation method	Photo-coupler insulation
Rated input voltage	DC 24V	Rated load voltage	DC24V
Rated input current	7 mA(fixed) 5mA(removable)	Rated load current	0.1A/1 point, 2A/1COM
Range of load voltage	DC 20.4~26.4V (ripple rate: less than 5%)	Range of load voltage	DC 20.4~26.4V
Max. synchronous input point	100% On synchronously	Leakage current when Off	Less than 0.1mA
On voltage/On current	More than DC19V / 3.0mA	Max. inrush current	Less than 0.4A/10ms
Off voltage/Off current	Less than DC6V / 1.5mA	Surge killer	None
Input resistance	About 3.3 kΩ	Response time	Off → On On → Off
Response time	Off → On		Less than 2 ms
	On → Off		Less than 2 ms
Common method	16 point/COM (Source/Sink type)	Max. voltage falling when ON	DC 1.0 V
Operation indication	LED ON when input ON	Common method	16 point / 1COM (sink type)
External supply consumption current	Terminal unit connector (M3 X 6 screws)		
External connection method	Less than 294mA		
Weight	Less than 240g (Fixed type)		

Circuit configuration

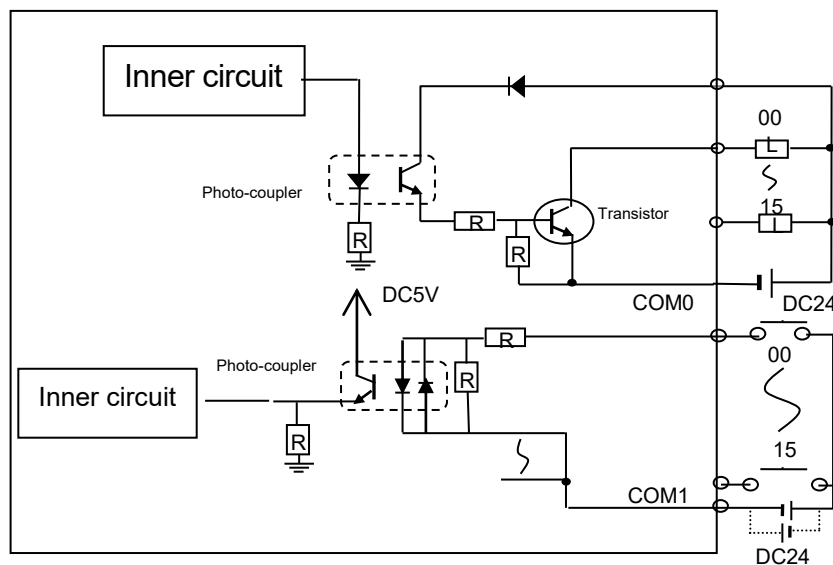

2.5.2 32 point I/O combo module (DC16/TR16 point)

I/O combined module				
Input		Output (TR 0.5A Source)		
Input point	16 points	Output point	16 points	
Insulation method	Photo-coupler insulation	Insulation method	Photo-coupler insulation	
Rated input voltage	DC 24V	Rated load voltage	DC 24V	
Rated input current	7mA(fixed), 5mA(removable)	Max. load current	0.5A/1 point, 3A/1COM	
Range of load voltage	DC20.4~26.4V (Ripple rate: Less than 5%)	Range of load voltage	DC 20.4~26.4V	
Max. synchronous input point	100% On synchronously	Leakage current when Off	Less than 0.1mA	
On voltage/On current	More than DC19V / 3.0mA	Max. inrush current	Less than 1A/10ms	
Off voltage/Off current	More than DC6V/ 1.5mA	Surge killer	None	
Input resistance	About 3.3 kΩ	Response time	Off→ On	Less than 2 ms
Response time	Off→ On		Less than 3 ms	On→ Off
	On → Off	Less than 3 ms	Max. falling voltage when On	DC 1.0 V
Common method	16 point/COM (Sink/Source type)	Common method	16 point / 1COM (Sink type)	
Operation indication	LED On when input On	Operation indication	LED On when input On	
External connection method	Terminal unit connector (M3 X 6 screws)			
External supply consumption current	Less than 294mA			
Weight	Les than 240g/290g (DT4B:Fixed type/DT4C: Removable type)			

Circuit configuration

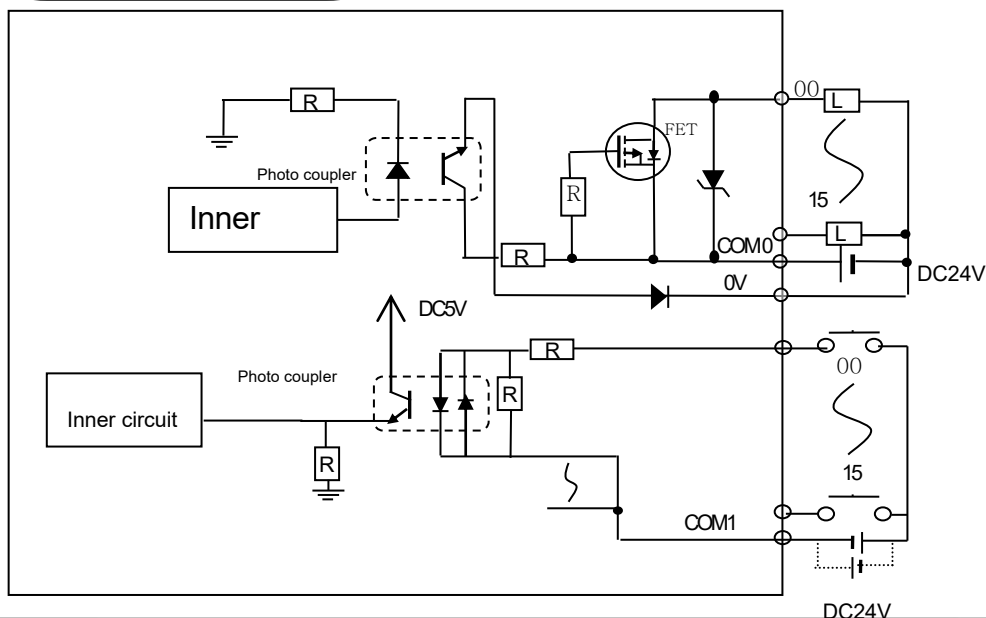

2.5.3 32 point I/O combo module (DC16/TR16 point)

I/O combined module				
Input		Output (TR 0.5A Sink)		
Input point	16 point	Output point	16 point	
Insulation method	Photo-coupler insulation	Insulation method	Photo-coupler insulation	
Rated input voltage	DC 24V	Rated load voltage	DC24V	
Rated input current	7mA(fixed), 5mA(removable)	Max. load current	0.5A/1 point, 3A/1COM	
Range of load voltage	DC20.4~26.4V (ripple rate: less than 5%)	Range of load voltage	DC 20.4~26.4V	
Max. synchronous input point	100% On synchronously	Leakage current when Off	Less than 0.1mA	
On voltage/On current	More than DC19V/ 3.0mA	Max. inrush current	Less than 1A/10ms	
Off voltage/Off current	Less than DC6V/ 1.5mA	Surge killer	None	
Input resistance	About 4.7 kΩ	Response time	Off → On	Less than 2 ms
Response time	Off → On		Less than 3 ms	On → Off
	On → Off	Less than 3 ms	Max. falling voltage when On	DC 1.0 V
Common method	16 point /COM (Sink/Source type)	Common type	16 Point / 1COM (Sink type)	
Operation indication	LED On when input on	Operation indication	LED On when output On	
External connection method	Terminal unit connector (M3 X 6 screws)			
External supply consumption current	Less than 294mA			
Weight	Less than 240g/290g (DT4A1:Fixed type/DT4C1: Removable type)			

Circuit configuration

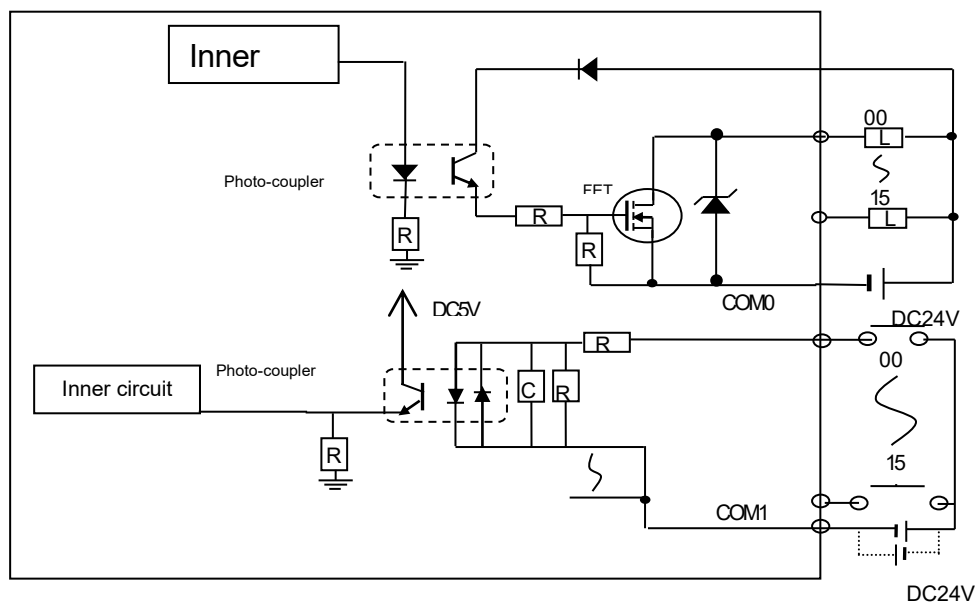

2.6 Modular type analogue module specification

2.6.1 Modular type analogue output module

(1) XBF-DV04A/ XBF-DC04A

Category		Specification			
		XBF-DV04A	XBF-DC04A	XBF-DC04B	
Analogue output	Type	Voltage	Current	Current	
	Range	DC 0 ~ 10V (Load resistor: more than 2 k Ω)	DC 4 ~ 20mA DC 0 ~ 20mA (Load resistor: less than 510 Ω)	DC 0 ~ 1.2mA (Load resistance: 510 Ω or less)	
	Range	Unsigned value	0 ~ 4,000	0 ~ 4,000	0 ~ 4,000
		Signed value	-2,000 ~ 2,000	-2,000 ~ 2,000	-2,000 ~ 2,000
		Precise value	0 ~ 1,000	400 ~ 2,000/0 ~ 2,000	0 ~ 1,200
Percentile value		0 ~ 1,000	0 ~ 1,000	0 ~ 1,000	
Max. resolution		2.5 mV (1/4,000)	5 μ A (1/4,000)	0.3 μ A(1/4,000)	
Precision		More than \pm 0.5%			
Max conversion speed		1 ms/channel			
Absolute Max. output		DC \pm 15V	DC +25 mA		
Output channel No.		4 channel			
Insulation method		Photo-coupler insulation between output terminal and PLC power (non-insulation between channels)			
Connection terminal		11point terminal			
Consum-ption current	Inner (DC 5V)	110 mA	110 mA		
	External (DC 21.6 ~26.4V)	70 mA	120 mA		
Weight		64 g	70 g		

(2) XBF-DV04C/ XBF-DC04C

Items		Performance specification		
		XBF-DV04C	XBF-DC04C	
Channels		4 channels		
Analog output range	Type	Voltage	Current	
	Range	DC 1 ~ 5V DC 0 ~ 5V DC 0 ~ 10V DC -10 ~ 10V (Load resistance: 1 kΩ or more)	DC 4 ~ 20 mA DC 0 ~ 20 mA (Load resistance: 600Ω or less)	
	Output ranges are set in user program or I/O parameter per each channel.			
Digital input	Type	16 bit binary data (Data : 14Bit)		
	Range	Unsigned value	0 ~ 16,000	
		Signed value	-8,000 ~ 8,000	
		Precise value	1,000 ~ 5,000 (1 ~ 5V) 0 ~ 5,000 (0 ~ 5V) 0 ~ 10,000 (0 ~ 10V) -10,000 ~ 10,000 (±10V)	4,000 ~ 20,000 (4 ~ 20 mA) 0 ~ 20,000 (0 ~ 20 mA)
		Percentile value	0 ~ 10,000	
Max. resolution		1/16,000		
		0.250 mV (1 ~ 5V) 0.3125 mV (0 ~ 5V) 0.625 mV (0 ~ 10V) 1.250 mV (±10V)	0.1uA (4~20mA) 1.25uA (0~20mA)	
Accuracy		±0.2% or less (When ambient temperature is 25°C) ±0.3% or less (When ambient temperature is 0 ~ 55°C)		
Max. conversion speed		1 ms/ channel		
Additional function		Setting of channel output status (Select one among previous, Min, Max value) Setting of interpolation method (Linear interpolation, S-type interpolation)		
Insulation method		Photo-coupler insulation between output terminal and PLC power (no insulation between channels)		
Terminal connected		11 point terminal		
Power Supply		DC 24V		
Weight		68g	69g	
Consumed current	Internal (DC 5V)	70mA		
	External (DC 24V)	160mA		

2.6.2 Modular type analogue input module
 (1) XBF-AD04A

Category	Specification																										
	XBF-AD04A																										
Analogue input	DC 0 ~ 10 V (Input resistance: 1 MΩ min.) DC 4 ~ 20 mA , DC 0 ~ 20 mA (Input resistance 250 Ω)																										
Analogue input range selection	► Analogue input range selection is done at the SyCon software after setting external switch. ► Each input range can be set according to the channel.																										
Digital output	<table border="1"> <tr> <td style="text-align: center;">Analogue input</td> <td>0~10 V</td> <td>4 ~ 20 mA</td> <td>0 ~ 20 mA</td> </tr> <tr> <td style="text-align: center;">Digital output</td> <td colspan="3"></td> </tr> <tr> <td>Unsigned value</td> <td colspan="3">0 ~ 4,000</td> </tr> <tr> <td>Signed value</td> <td colspan="3">-2,000 ~ 2,000</td> </tr> <tr> <td>Precise value</td> <td>0 ~ 1,000</td> <td>400 ~ 2,000</td> <td>0 ~ 2,000</td> </tr> <tr> <td>Percentile value</td> <td colspan="3">0 ~ 1,000</td> </tr> </table>	Analogue input	0~10 V	4 ~ 20 mA	0 ~ 20 mA	Digital output				Unsigned value	0 ~ 4,000			Signed value	-2,000 ~ 2,000			Precise value	0 ~ 1,000	400 ~ 2,000	0 ~ 2,000	Percentile value	0 ~ 1,000				
	Analogue input	0~10 V	4 ~ 20 mA	0 ~ 20 mA																							
	Digital output																										
	Unsigned value	0 ~ 4,000																									
	Signed value	-2,000 ~ 2,000																									
Precise value	0 ~ 1,000	400 ~ 2,000	0 ~ 2,000																								
Percentile value	0 ~ 1,000																										
Max. resolution	Analogue input range	Resolution (1/4,000)																									
	0 ~ 10 V	2.5 mV																									
	4 ~ 20 mA	5 μA																									
Precision	Less than ±0.5%																										
Max. conversion speed	1.5 ms/channel																										
Absolute max input	voltage : ±15 V, current : ±30 mA																										
Analogue input point	4channel/1module																										
Insulation method	Photo-coupler insulation between output terminal and PLC power (non-insulation between channels)																										
Connection terminal	11point terminal																										
External power supply	Power input range	DC21.6V ~ DC26.4V																									
	Consumption current	120 mA																									
Weight	67g																										

Voltage/current selection switch

► switch for selecting the voltage/current of analogue input

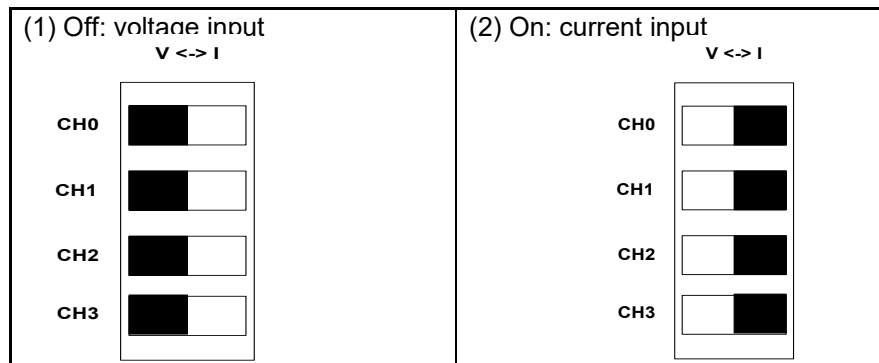

Remark

- 1) In the A/D conversion module, offset/gain value about each analogue input range is set in the factory. It is not available to change it by user
- 2) Modular type Smart I/O Dnet adapter module
 The default value of parameter is 0x0000000 (This value is effective when off status. In the voltage mode you should change parameter.)
 → All channel (Enable), input (DC 0~10 V), analogue input range (0 ~ 4,000)

2) XBF-AD08A

Items		Performance specification		
Number of channels		8 channels		
Analog input	Type	Voltage	Current	
	Range	DC 1 ~ 5V DC 0 ~ 5V DC 0 ~ 10V (Input resistance: 1 MΩ min)	DC 4 ~ 20mA DC 0 ~ 20mA (Input resistance: 250 Ω)	
		Current input or Voltage input can be selected through the external voltage/current switch.		
Digital output	Type	12 bit binary data		
	Range	Unsigned value	0 ~ 4,000	
		Signed value	-2,000 ~ 2,000	
		Precise value	100 ~ 500 (1 ~ 5V) 0 ~ 500 (0 ~ 5V) 0 ~ 1,000 (0 ~ 10V)	400 ~ 2,000 (4 ~ 20 mA) 0 ~ 2,000 (0 ~ 20 mA)
			Percentile value	0 ~ 1,000
Max. resolution	1/4,000 1.25 mV (1 ~ 5V, 0 ~ 5V) 2.5 mV (0 ~ 10V)	5 μA (4 ~ 20 mA, 0 ~ 20 mA)		
Accuracy	±0.5% or less			
Max. conversion speed	1.5 ms/ channel			
Absolute max. input	DC ±15V	DC ±25 mA		
Addition function	Filter	Digital filter(4 ~ 64,000 ms)		
	Average	Time average (4~16,000 ms)		
		Count average (2~64,000times)		
		Moving average (2~100ea)		
Detection alarm	Disconnection(DC 1~5V, DC 4~20 mA)			
Insulation method	Photo-coupler insulation between input terminal and PLC power (No insulation between channels)			
Connection terminal	11 point terminal block			
Consumption current	Internal (DC 5V)	105mA		
	External (DC 24V)	85mA		
Weight	81g			
Module input power	DC 20.4~28.8V			

(3) XBF-AD04C

Items		Performance specification		
Number of channels		4 channels		
Analog input	Type	Voltage	Current	
	Range	DC 1 ~ 5V DC 0 ~ 5V DC 0 ~ 10V DC -10 ~ 10V (Input resistance: 1 M Ω min)	DC 4 ~ 20mA DC 0 ~ 20mA (Input resistance: 250 Ω)	
		Current input or Voltage input can be selected through the external terminal wiring setting. ▶ In voltage mode, use V+ and COM terminal for the channel. In current mode, short V+ and COM terminal and then use I+ and COM terminal.		
Digital output	Type	16 bit binary data (Data : 14Bit)		
	Range	Unsigned value	0 ~ 16,000	
		Signed value	-8,000 ~ 8,000	
		Precise value	1,000 ~ 5,000 (1 ~ 5V) 0 ~ 5,000 (0 ~ 5V) 0 ~ 10,000 (0 ~ 10V) -10,000 ~ 10,000 (\pm 10V)	4,000 ~ 20,000 (4 ~ 20 mA) 0 ~ 20,000 (0 ~ 20 mA)
			Percentile value	0 ~ 10,000
Max. resolution	1/16,000 0.250 mV (1 ~ 5V) 0.3125 mV (0 ~ 5V) 0.625 mV (0 ~ 10V) 1.250 mV (\pm 10V)			
Accuracy	\pm 0.2% or less (When ambient temperature 25°C) \pm 0.3% or less (When ambient temperature 0 ~ 55°C)			
Max. conversion speed	1 ms/ channel			
Absolute max. input	DC \pm 15V	DC \pm 30 mA		
Addition function	Filter	Digital filter(4 ~ 64,000 ms)		
	Average	Time average (4~16,000 ms)		
		Count average (2~64,000times)		
	Detection alarm	Disconnection(DC 1~5V, DC 4~20 mA)		
	Alarm function	When input signal exceeds the effective range, relevant flag turns on.		
Insulation method	Photo-coupler insulation between input terminal and PLC power (No insulation between channels)			
Connection terminal	15 point terminal block			
Consumption current	Internal (DC 5V)	105mA		
	External (DC 24V)	100mA		
Weight	72g			
Module input power	DC 20.4~28.8V			

2.6.3 Modular type RTD sensor module (XBF-RD04A)

Category		Specification
		XBF-RD04A
No. of input channel		4 channels
Input sensor type	PT100	JIS C1604-1997
	JPT100	JIS C1604-1981 , KS C1603-1991
Input Tem. range	PT100	-200 ~ 600°C
	JPT100	-200 ~ 600°C
Digital output	PT100	-2,000 ~ 6,000
	JPT100	-2,000 ~ 6,000
Precision	Room temp. (25°C)	Less than ±0.3%
	All range (0~55°C)	Less than ±0.5%
Conversion speed		40ms / channel
Insulation method	Between channel	Non-insulation
	Terminal – PLC power	Insulation (Photo-Coupler)
Terminal unit		15point terminal
I/O occupation point		Fixed type: 64point
Sensor wire method		3 line
Max. mount No.		4
Consumption current	Inner DC5V	100mA
	external DC24V	900mA
weight		63g

Remark

The default value of the extension Smart I/O Dnet adapter module parameter is 0x0000000F.
 → all channel (Enable), Tem. Unit (Celsius), Input sensor type (PT100)

2.6.4 Thermocouple input module (XBF-TC04S)

Category		Specification	
No. of input channel		4 channels	
Input sensor type		Thermocouple K / J / T / R type JIS C1602-1995	
Temp. range	K	-200.0°C ~ 1300.0°C	
	J	-200.0°C ~ 1200.0°C	
	T	-200.0°C ~ 400.0°C	
	R	0.0°C ~ 1700.0°C	
Digital output	Temp. unit	To one decimal place – Note1) K, J, T type: 0.1°C, R type: 0.5°C	
	Scaling (User range setting)	Unsigned scaling (0 ~ 65535) Signed scaling (-32768 ~ 32767)	
Precision	Normal temp. (25°C)	Within ±0.2% – Note2)	
	Temp. coefficient (Operating temp. range)	±100 ppm/°C	
Conversion speed		50ms / channel	
Insulation	Method	Terminal – internal circuit	Photo coupler insulation
		Terminal – Power	DC/DC converter insulation
		Between channels	Photo MOS relay insulation
	Withstanding voltage		400 V AC, 50/60 Hz, 1minute, Leakage current 10 mA or less
	Insulation resistor		500 V DC, 10 MΩ or above
Reference contact point compensation	Automatic compensation by RJC sensor (Thermistor)		
	Compensation amount	±1.0°C	
Warming-up time		15 min or above	
Terminal block		11-point terminal	
Occupation points		64 points	
Max installation count		4	
Consumption current	Internal DC5V	100 mA	
	External DC24V	100 mA	
Weight		63g	

2.6.5 Analog I/O module (XBF-AH04A)

(1) Performance of input part

Category		Input performance specification		
No. of input channel		2 channels		
Analog input range	Type	Voltage	Current	
	Range	DC 1 ~ 5V DC 0 ~ 5V DC 0 ~ 10V (Input resistor: 1 MΩ or above)	DC 4 ~ 20 mA DC 0 ~ 20 mA (Input resistor 250 Ω)	
		Input range can be set per channel by user program or after setting I/O parameter, voltage/current selector switch		
Digital output	Type	12 bit binary data		
	Range	Unsigned value	0 ~ 4,000	
		Singed value	-2,000 ~ 2,000	
		Precise value	100 ~ 500 (DC 1 ~ 5V) 0 ~ 500 (DC 0 ~ 5V) 0 ~ 1,000 (DC 0 ~ 10V)	400 ~ 2,000 (DC 4 ~ 20 mA) 0 ~ 2,000 (DC 0 ~ 20 mA)
		Percentile value	0 ~ 1,000	
Max. resolution	1/4,000 1.25 mV (DC 1~5V, 0~5V) 2.5 mV (DC 0~10V)	5 μA (DC4~20 mA, 0~20 mA)		
Precision	±0.5% or less			
Max. conversion speed	1ms/channel			
Absolute max. input	DC ±15V	DC ±25 mA		

(2) Performance of output part

Category		Output performance specification		
No. of output channel		2 channels		
Analog output range	Type	Voltage	Current	
	Range	DC 1 ~ 5V DC 0 ~ 5V DC 0 ~ 10V (Load resistor: 2kΩ or above)	DC 4 ~ 20 mA DC 0 ~ 20 mA (Load resistor 510 Ω or less)	
		Range can be set per channel by user program or after setting I/O parameter, voltage/current selector switch		
Digital input	Type	12 bit binary data		
	Range	Unsigned value	0 ~ 4,000	
		Signed value	-2,000 ~ 2,000	
		Precise value	100 ~ 500 (DC 1 ~ 5V) 0 ~ 500 (DC 0 ~ 5V) 0 ~ 1,000 (DC 0 ~ 10V)	400 ~ 2,000 (DC 4 ~ 20 mA) 0 ~ 2,000 (DC 0 ~ 20 mA)
		Percentile value	0 ~ 1,000	
Max. resolution	1/4,000 1.25 mV (DC 1~5V, 0~5V) 2.5 mV (DC 0~10V)	5 μA (DC4~20 mA, 0~20 mA)		
Precision	±0.5% or less			
Max. conversion speed	1ms/channel			
Absolute max. output	DC ±15V	DC 25 mA		

2.7 Communication Module Specification

2.7.1 Profibus-DP Module Specification

1) Stand-alone type module

Category	Specification
Module Type	Slave
Standard	EN 50170 / DIN 19245
Interface	RS-485 (Electric)
Medium access	POLL
Encoding method	NRZ
Cable	Shielded Twisted Pair
Communication distance	1200m (9.6K ~187Kbps)
	400m (500 Kbps)
	200m (1.5 Mbps)
	100m (3M ~ 12Mbps)
Max. node	126 stations
Max. node (per segment)	32 stations
Max. I/O data	244 Byte

2) Modular type module

Category	Specification					
Standard	EN50170 / DIN 19245					
Interface	RS-485					
Medium access	Polling					
Topology	Bus					
Encoding method	NRZ					
Communication interface	Sink mode, Freeze mode Auto baud rate					
Master/Slave	slave					
Cable	Shielded Twisted Pair					
Communication speed and distance	Speed (Kbps)	9.6	19.2	93.75	187.5	500
	Distance (m)	1200	1200	1200	1000	400
	Speed (Kbps)	1500	3000	6000	12000	-
	Distance (m)	200	100	100	100	-
Max. node	100 station (setting range: 0 ~ 99)					
Max. modular type I/O equipment No.	8					
Max. digital I/O point	512 point (input Max. 256 point/output max. 256 point)					
Max. analog I/O channel No.	32 channels (input Max. 16 channels/output Max. 16 channels) (analog module occupy digital 64 point)					
input power	Rated input voltage/current	DC 24V/ 0.55A				
	Power range	DC19.2 ~ 28.8V				
	Output voltage/current	5V(±20%) / 1.5A				
	Insulation	Non-insulation, communication part insulation				
Basic specification	Weight (g)	100				

2.7.2 DeviceNet Module Specification

1) Stand-alone type module

Category		Specification
Module type		slave
Communication speed setting method		Auto baud rate
Cable		Class 2 Thick/Thin Cable (Allen-Bradley standard)
Communication speed		125/250/500 Kbps
Communication distance (Thick)		500/250/100 m
Max. drop length	125 Kbps	6m (max. extension 156m)
	250 Kbps	6m (max. extension 78m)
	500 Kbps	6m (max. extension 39m)
Data packet		0 ~ 8 Byte (64 Bits)
Network construction		<ul style="list-style-type: none"> • Trunk/Drop line • Power/Signal line in same network
Communication method		<ul style="list-style-type: none"> • Poll, Bit-strobe, COS/Cyclic method
Max. node		Max. 64 MAC ID (Including master) 32 I/O per node (max. 2,048 I/O)
System type		Node insertion/removal in voltage ON
Operation voltage		DC 24V (Tolerance range: DC11V~ 28.8V)

2) Modular type module

Category		Specification		
Communication interface		Poll, Bit-strobe, COS/Cyclic		
		Group 2 only slave		
		Auto baud rate		
Master/slave		Slave		
Max. station		64 (including master)		
Max. No. of extension I/O equipment		8		
Max. digital I/O point		512 point (input max 256 point/output max 256 point)		
Max. No. of analog I/O channel		Input 16 channels (output 16 channels)		
Communication speed and distance	speed	125 kbps	250 kbps	500 kbps
	distance	500 m	250 m	100 m
Input power	Rated input voltage	DC 24V		
	Power range	19.2V ~ 28.8V (available to operate in 11V)		
	Output voltage/current	5V(±20%) /1.5A		
	Insulation	Non-insulation		
Basic specification	Weight (g)	100		

2.7.3 Rnet Module Specification

1) Stand-alone type module

Classification	Specification
Allowable inspection power cut time	20 ms
Communication speed	1Mbps
Communication method	Semi dual bit serial method
Synchronous method	Frame synchronous method
Transmission path method	BUS
Total extension distance	750m
No. of connecting station	With repeater: 64 stations (including master stations) Without repeater: 32 stations (including master stations)
Modulation method	Manchester Bi-phase-L
Error control method	Retry by CRC-CCITT and Time Over
Connector connection	5-PIN D-Sub connector type
Using cable	Twisted air shielded cable
No. of communication point	16 points / 32 points

2) Modular type module

Classification		Specification
Commu nication	Communication speed	1Mbps
	Transmission path method	BUS
	Total extension distance	750m
	Connector connection	Open type 5 pin connector (D-sub connector)
	Used cable	Twisted pair shielded cable
	No. of NOD (based on master)	32: repeater not used, 64: repeater used
	Max. digital I/O point	512 (input: 256, output: 256)
	Max. I/O connection number	Analog 8/Digital 4
	Extension analog module occupation number	2 byte
	Latch/Clear select	Operation by mode change switch
Power	Rated input voltage/current	DC 24V/0.55A
	Power range	DC 19.2V ~ 28.8V
	Output voltage/current	5V(±20%)/1.5A
	Insulation	Non-insulation
-	Weight(g)	100

2.7.4 Snet Module Specification

Classification	Snet
Module type	Remote slave
Protocol	Modbus-RTU
Max. protocol size	8 Byte
Topology	BUS
Cable	Twisted air shielded cable
Communication speed	2400 ~ 38,400 BPS
Communication distance	1 km
Medium access	POLL
Max. node	32 stations
Communication point	32 points

Remark

1) Notice in installing I/O module of modular type
 Maximum current that Pnet, Dnet and Rnet adapter module can support is 1.5A so I/O module have to be configured less than 1.5A.

2.7.5 Enet Module Specification

	Classification	Specification
Communication	Communication speed	10/100Mbps
	Transmission path method	Base Band
	Standard Functions	IEEE 802.3
	Flow Control	HALF/FULL
	Modulation type	NRZI
	Max. distance between nodes	100m
	Max. protocol size	Data 1500byte
	Communication zone access method	CSMA/CD
	Check method for frame error	CRC32
	Connector connection	RJ-45(2Port)
	IP Setting	S/W Setting
	Topology	Bus, Star
	Protocol	MODBUS/TCP, EtherNet/IP
	Max. digital I/O point	512 (input 256, output 256)
	Max. digital I/O connection number	8
Max. analog I/O connection number	8	
Expansion analog module occupation number	8byte	
Power	Rated input voltage/current	DC 24V/0.7A
	Power range	DC 19.2V ~ 28.8V
	Output voltage/current	5V($\pm 20\%$)/1.5A
	Insulation	Non-insulation
-	Weight(g)	100

2.7.6 RAPIenet Module Specification

Classification		Specification
Communication	Network type	RAPIenet
	Protocol standard	IEC 61158, IEC-61784-2
	Max. communication distance	≤100m
	Topology	Line, Ring
	Max. node	64 개국(0~63 번)
	Max. packet	1500 Packet/sec
	Min. transmitting cycle	5ms
	Communication speed	100Mbps
	Transmission path method	Base Band
	Communication zone access method	CSMA/CD

2.8 Communication Cable Specification

2.8.1 Profibus-DP cable specification

(1) Cable specification

Classification	Contents	
Cable	▶ BELDEN cable:: Product name : 3077F, 3079A ▶ Tomas cable : Product name : Profibus-DP UNITRONIC-BUS L2/FIP/BUS	
AWG	22	
Type	BC (Bare copper)	
Insulation	PE (Polyethylene)	
Insulation intensity	0.035 (inch)	
Shield	Aluminum Foil-Polyester Tape /Braid Shield	
Capacity	8500 pF/ft	
Characteristic impedance	150 Ω	
Core No.	2 Core	

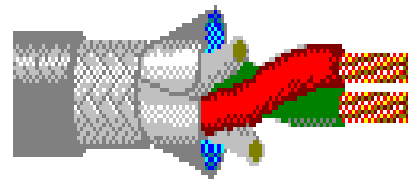

(2) Connector's structure and connector wire method

- A) input wire: green line is connected to A1, red line is connected to B1.
- B) output wire: green line is connected to A2, red line is connected to B2.
- C) Shield is connected to connector's clamp.
- D) When installing the connector in terminal, install cable at the A1.B1.

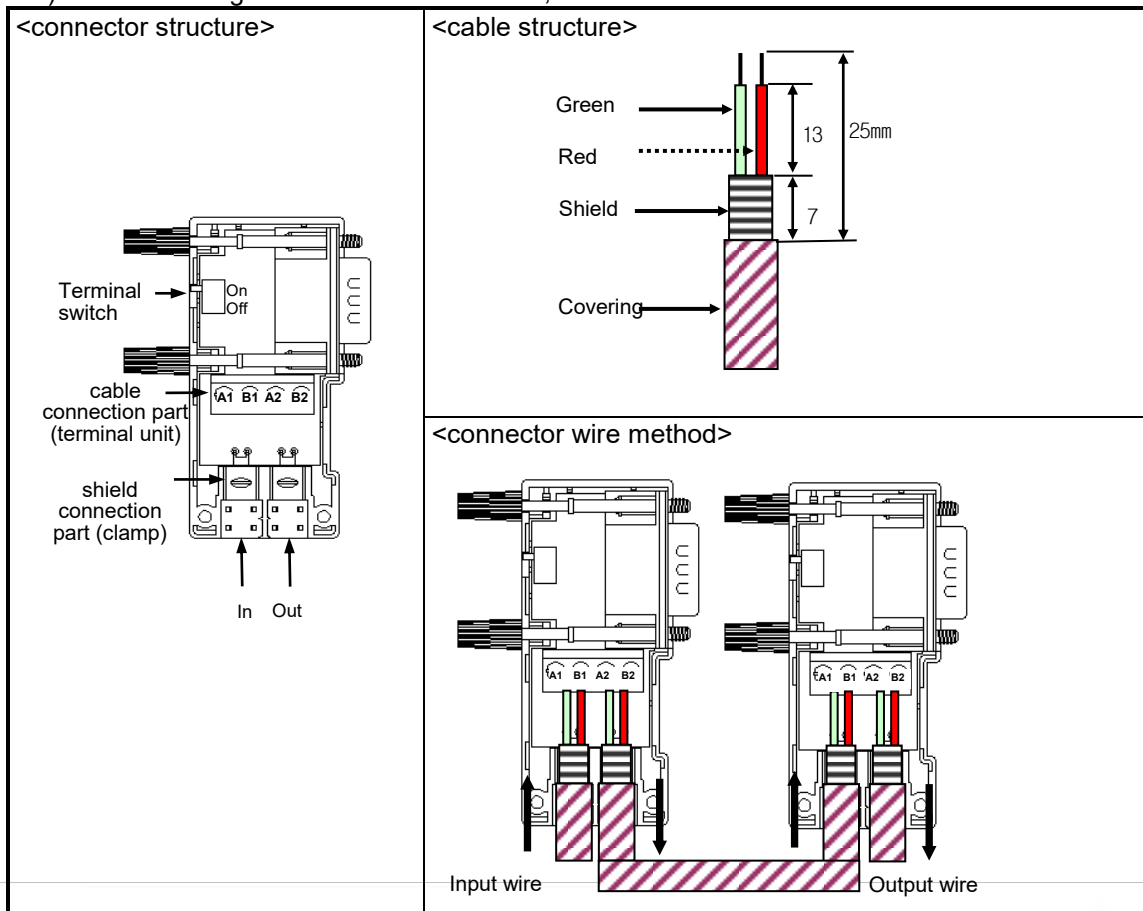

2.8.2 DeviceNet Cable Specification

• Cable Specification

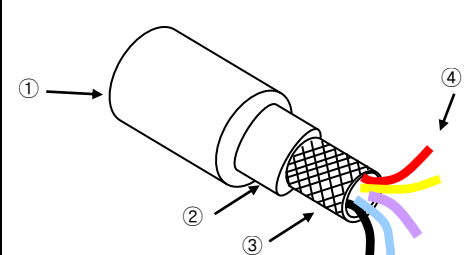
Type name	Cable class		Cable structure	
	Thick	Thin		
Maker	Belden			
Cable appearance	Round			
Max. allowed current (power)	8A	3A		
Max/ allowed current (communication line)	5A	1.7A		
External radius	12.2mm	7.1mm		
Core No.	5	5		
5 is Cable	① Insulation covering	Gray		Gray
	② Middle covering	Mylar tape		
	③ Copper-film covered shield	shield		
	④ Signal cable	Blue		CANL
White		CANH	CANH	
Red		24V	24V	
Black		24G	24G	

Cable Signal Name
Smart I/O Dnet I/F module cable have cores as follows. It composed of Twist pair cable for DC 24V

power supply, Twist pair cable for signal cable, shield Trunk/Drop cable etc. and both Thick and Thin cable are available for Trunk/Drop line.

Cable color	Signal name	Description
White	CAN_H	Signal cable
Blue	CAN_L	Signal cable
Bare	Drain	Shielded cable
Black	V-	Power cable
Red	V+	Power cable

• Max. transmission distance by Cable types

Transmission speed	Max. distance	
	Thick cable	Thin cable
125kbps	500m	100m
250kbps	250m	100m
500kbps	100m	100m

2.8.3 Rnet Cable Specification

• Twisted Pair Cable

Cable Description			
Product name	Low Capacitance Lan Interface Cable		
Type name	LIREV-AMESB		
Specification	2*0.64 mm (GS 92-3032,22 AWG)		
Maker	LS Cable		
Electric characteristics			
Items	Unit	Characteristics	Test condition
Conductor resistance	Ω/km	Less than 59	Normal temp.
Voltage-resistance(DC)	V/min	500V 1 min resist	In air
Insulation resistance	MEGA Ω-km	More than 1,000	Normal temp.
Capacitance	pF/m	Less than 45	1 KHz
Characteristic impedance	Ω	120 ± 12	10MHz
Appearance characteristics			
Conductor	No. of core wire	CORE	2
	Specification	AWG	18
	Composition	NO./mm	1/1.0
	Outside diameter	mm	1.0
Insulator	Thickness	mm	0.9
	Outside diameter	mm	2.8

• Structure Diagram

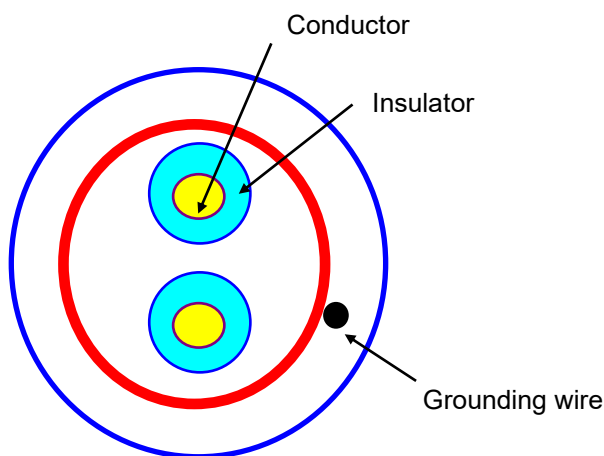

2.8.4 Snet Cable Specification

In case of Snet communication using RS-422 channel, it is required to use Twist pair cable for RS-422 considering communication distance and communication speed. The table below shows the specification of recommended cable. In case of using other cables, it is required to use the cable suitable for the following characteristics.

- θ Product name : Low Capacitance Lan Interface Cable
- θ Type name : LIREV-AMESB
- θ Specification : 2P X 22AWG(D/0.254 TA)
- θ Maker : LS Cable

Twist Pair Cable Specification

1) Electric Characteristic

Test Items	Unit	Characteristics	Test Condition
Conductor resistance	Ω/km	Less than 59	Normal temp.
Voltage-resistance(DC)	V/1min	500V 1 min resist	In air
Insulation resistance	MΩ-km	More than 1,000	Normal temp.
Capacitance	Pf/M	Less than 45	1kHz
Characteristics impedance	Ω	120 ± 12	10MHz

2) Appearance Characteristic

Items		Single Wire	
Conductor	No. of core wire	Pair	2
	Spec.	AWG	22
	Composition	NO./mm	1/0.643
	Outside diameter	Mm	0.643
Insulator	Thickness	Mm	0.59
	Outside diameter	Mm	1.94

* Structure Diagram

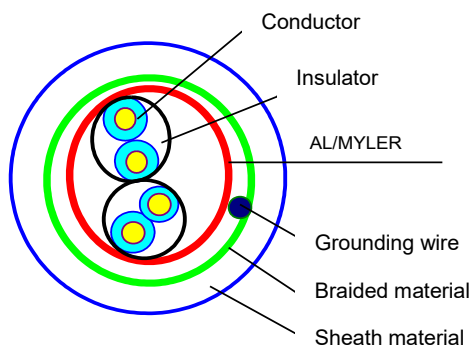

2.8.5 Enet Cable Specification

1) UTP cable

UTP cable is classified into 2 types based on the following criteria.

- ① Shield: classified into 3 (UTP, FTP, STP)
- ② Frequency band used: classified into 7 (Cat.1~7)

2) Type of cables (shield)

Classification	Details	Purpose
UTP (or U.UTP)	Unshielded cable. High speed data transmission.	Max. 200MHz Phonetic+Data+Low grade of video signal
FTP (or S.UTP)	Shielded cable core only.	Max.100MHz Electronic impediment (EMI) and electric stability considered Phonetic+Data+Low grade of video signal
STP (or S.STP)	Double-shielded cable. Shielded core and Individually shielded Pair cable	Max. 500MHz Phonetic+Data+Video signal Substitute for 75Ω coaxial cable

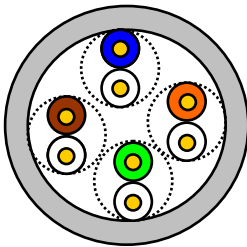

UTP

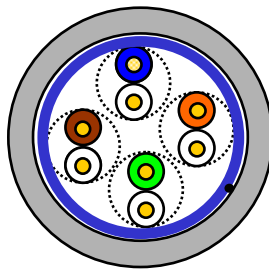

FTP

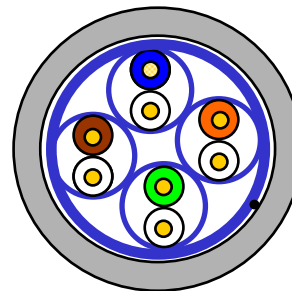

STP

Notes

1) UTP : Unshielded Twisted Paired Copper Cable

FTP : (Overall) Foiled Twisted Paired Copper Cable

STP : (Overall) Shielded(and Shielded Individually Pair)Twisted Paired Copper Cable

2) Patch Cable(or Patch Cord)

Conductor composed of stranded cable instead of solid conductor may be used to increase the flexibility of UTP 4-pair cable. And surface specification and materials used is Un-coated AWG 24 (7/0203A).

In other words, the diameter of a single cable is 0.203mm, and this cable is of 1+6 structure as standardized with annealed copper cable.

3) Classification based on frequency used

Classification	Frequency used (MHz)	Transmission Speed (Mbps)	Purpose
Category 1	Phonetic Frequency	1	Phone network (2-Pair)
Category 2	4	4	Multi-Pair communication cable
Category 3	16	16	Phone network + Computer network
Category 4	20	20	1) Computer network transmission speed Up 2) Low-loss communication cable
Category 5 and Enhanced Category 5	100	100	1) Digital Phone network + Computer network 2) Low-loss, broadband cable

Notes

1) Presently classified items are Category 3, 5, En-Cat.5 and Cat.6 inside and outside of the country, where Category 4 has been replaced by Category 5 and Category 7 is being under development all over the world as STP structure.

4) Example (CTP-LAN5) of Category 5 twisted-pair cable (UTP)

Item	Unit	Value	
Conductor resistance(Max)	Ω /km	93.5	
Insulation resistance(Min)	M Ω ·km	2,500	
Voltage endurance	V/min	AC 500	
Characteristic impedance	Ω (1~100MHz)	100 ± 15	
Attenuation	dB/100m or less	10MHz	6.5
		16MHz	8.2
		20MHz	9.3
Near-end crosstalk Attenuation	dB/100m or less	10MHz	47
		16MHz	44
		20MHz	42

2.9 Terminating

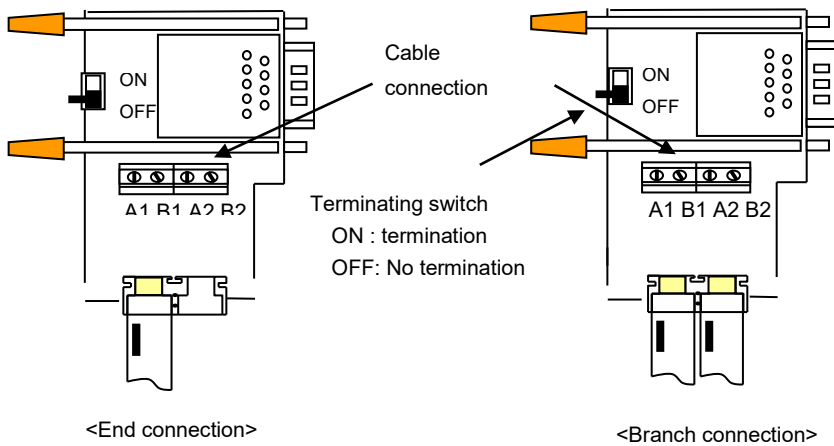

2.9.1 Profibus-DP Terminating

• Connection Connector



2.9.2 DeviceNet Terminating

• Connection connector

Classification	Cable connection method	
	Simplex communication connector	Duplex communication connector
Form		

• Terminal resistance

- 121Ω, 1%, 1/4W resistance should be added.
- Connected to CAN_H of connector and CAN_L signal cable

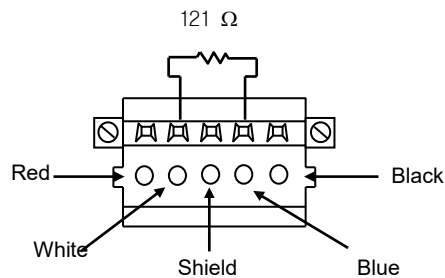

Remark

1) Terminal resistance should be added to both end of trunk line of network and in case of composing by device port tab, it is required to install terminal resistance on both ends of tab. In case that terminal resistance is omitted, the normal communication is not available.

2.9.3 Rnet Terminating

Signal cable for electric network connection for Smart I/O Rnet uses no.6 and 7 from connector pin of Rnet master module and no.8 and 9 of Smart I/O module.

No.6 signal of master module is connected to no.8 signal cable of Smart I/O module and no.7 signal is connected to no.9 signal cable respectively.

As each connector body is connected to other module by shield cable which plays the role to bypass the external noise, the connector bodies of both side should be connected by shield cable and the body of cable connector is not allowed to contact to high voltage and high current cables.

When soldering the shield cable to 9 pin connector body, it is required to heat the connector body with soldering iron sufficiently for strict and non removable soldering. In case of soldering, use the suitable amount of solder as too much solder adding makes the assembly of connector case difficult.

- Resistance value : 110Ω, 1/2W
- Connection pin no.
 - Master connection section : Pin no.6, 7
 - Smart I/O connection section : Pin no.8, 9
- Terminal resistance as fittings(110Ω, 1/2W) should be added on both ends of network.
- Connector case and end resistance are not allowed to contact each other.

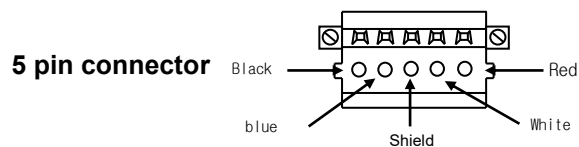
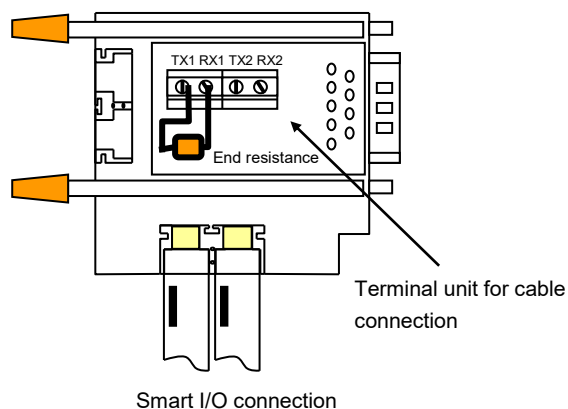
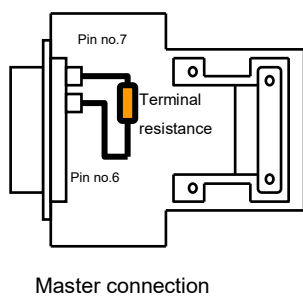

2.9.4 Snet Terminating

In case of communicating through RS-422 channel, it should be required to connect the terminal resistance from outside. In case of long distance communication, terminal resistance plays the role to prevent the signal distortion caused by reflection wave of cable and is required to connect the resistance ($1/2W$) same as characteristic impedance value to the end of network. In case of using the recommended cable, please connect 120Ω terminal resistance to both end of cable. In case of using other cables except the recommended cable, it is required to connect the $1/2W$ resistance same as the characteristic impedance value of using cable to both sides of cable.

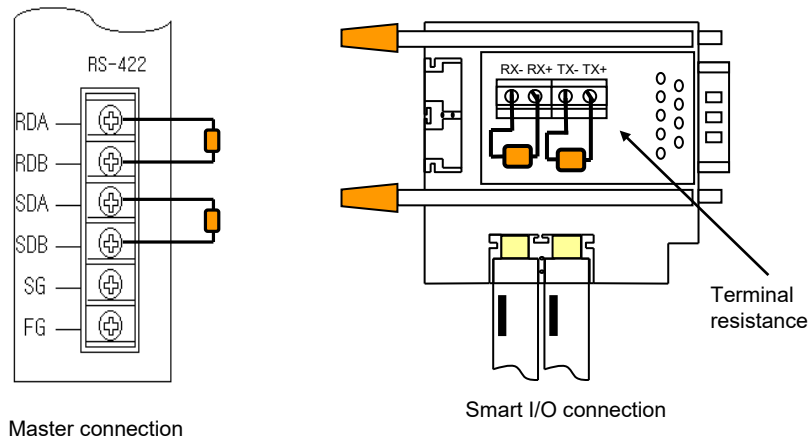

Chapter 3 System Configuration

Smart I/O series are equipped with various product suitable for system configuration as various communication models and I/O module. This chapter describes the method of system configuration and characteristics.

3.1 Notices in Selecting Module

Here describes the notices in selecting digital I/O module which is used for Remote I/O.

1) Digital input types contain the current sink input and current source input. In case of DC input module, as the wiring method of external input power is different according to such input types, make sure of selecting the input module considering the spec. of input connection machine. Remote I/O is available for source/sink in common. The wiring method per type is as follows.

(1) How to connect the sink type external connection machine to the source type DC input module.

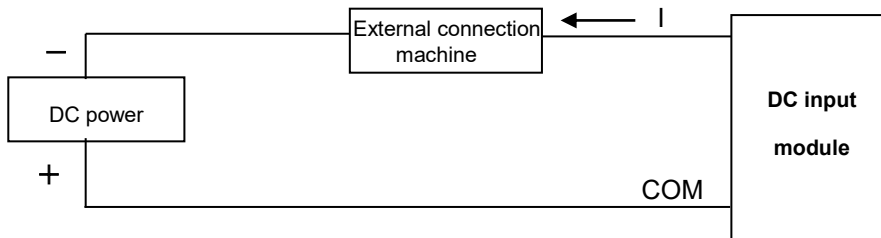

- External connection machine is located between DC power and (-) terminal of DC input module terminal.
- Thus, when inputting ON, the current flows from DC input module terminal to external connection machine.

(2) How to connect the source type external connection machine to the sink type DC input module.

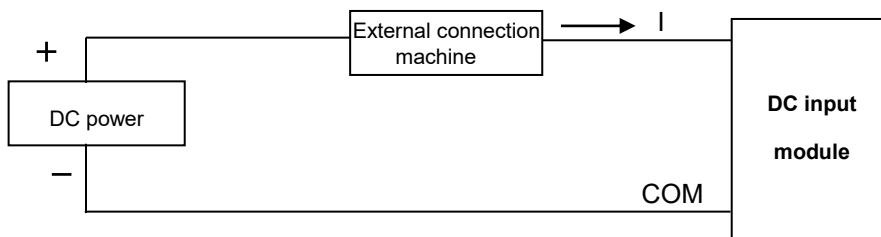

- External connection machine is located between DC power and (+) terminal of DC input module terminal.
- Thus, when inputting ON, the current flows from external connection machine to DC input module terminal.

2) In case that the open/close frequency is high or it is used to open/close the conductive load, please use transistor output module as Relay output module may reduce the life.

3.2 Names of Each Part

3.2.1 Basic System Configuration

Smart I/O series contain all 4 kinds of module configuration. According to network configuration that the user wants, it is available to install the system simple and effectively by the combination of the following models. The best advantage of Smart I/O series is the simple system configuration and the easy connection with other maker's machine as this is oriented to the open type network (except for Rnet).

Example of Smart I/O Series (stand-alone type)

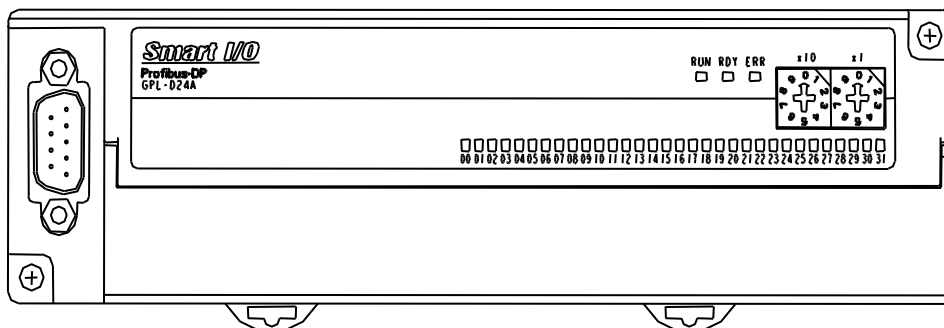

Example of Smart I/O Series (modular type)

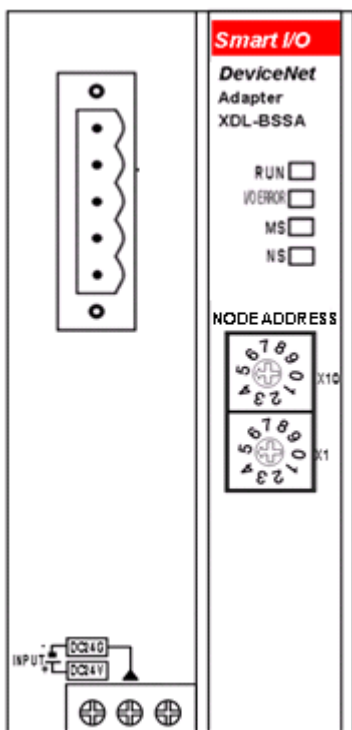

Available modules for network of Smart I/O series (I/O module)

I/O configuration available point		16 points or 32 points
Product type	Profibus-DP Communication module	<ul style="list-style-type: none"> • GPL-TR2A/TR2B/TR2C/TR2A1/TR2C1 • GPL-TR4A/TR4B/TR4C/TR4A1/TR4C1 • GPL-D22A/D22C, GPL-D24A/D24C, • GPL-RY2A/RY2C • GPL-DT4A/DT4B/DT4C/DT4A1/DT4C1 • GPL-DV4C • GPL-DC4C • GPL-AV8C • GPL-AC8C • XPL-BSSA
	DeviceNet Communication module	<ul style="list-style-type: none"> • GDL-TR2A(N)/TR2B/TR2C/TR2A1/TR2C1 • GDL-TR4A(N)/TR4B/TR4C/TR4A1/TR4C1 • GDL-D22A(N)/D22C, GDL-D24A(N)/D24C, • GDL-RY2A(N)/RY2C • GDL-DT4A(N)/DT4B/DT4C/DT4A1/DT4C1 • XDL-BSSA
	Rnet Communication module	<ul style="list-style-type: none"> • GRL-TR2A(N)/TR2C1/TR2C/TR4A/TR4C1/TR4C • GRL-RY2A(N)/RY2C • GRL-D22A(N)/D22C/D24A/D24C • GRL-DT4A(N)/DT4C1/DT4C • XRL-BSSA
	Snet Communication module	<ul style="list-style-type: none"> • GSL-TR2A/TR2C1/TR2C/TR4A/TR4C1/TR4C • GSL-RY2A/RY2C • GSL-D22A/D22C/D24AD24C • GSL-DT4A/DT4C/DT4C1
	Enet Communication module	<ul style="list-style-type: none"> • XEL-BSSA/BSSB
	RAPIenet Communication module	<ul style="list-style-type: none"> • GEL-TR4C1 • GEL-RY2C • GEL-D24C • GEL-DT4C1 • GEL-DV4C • GEL-DC4C • GEL-AV8C • GEL-AC8C

3.2.2 Names of Each Part of Smart I/O series

1) Pnet, Rnet, Snet, Dnet series

Profibus-DP, Rnet, Modbus communication module have all the same forms, and their characteristics are as follows.

In case of I/O 16 points

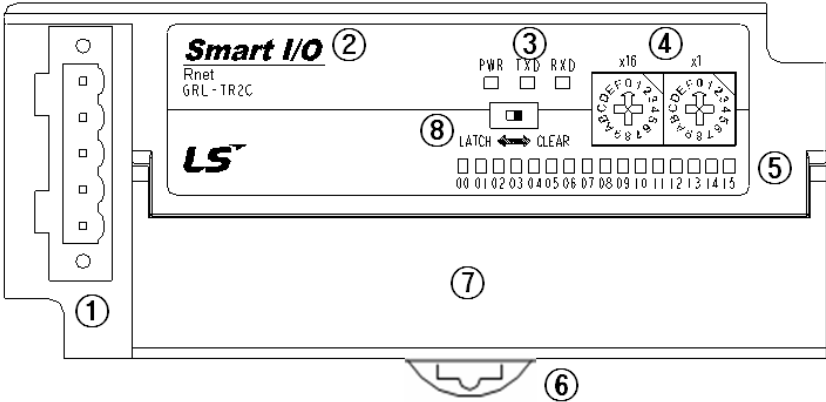

In case of I/O 32 points,

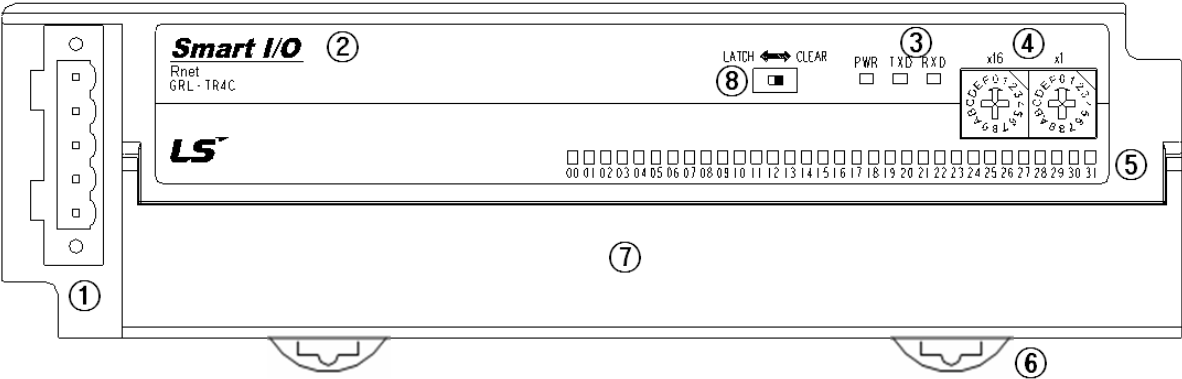

(1) Pnet module

No.	Item	Description
①	Connection connector	Connector for communication connection with master/remote unit • 9 pin connector
②	Smart I/O type name indication	<ul style="list-style-type: none"> Describes Profibus-DP module type name. GPL-D22A/D22C : DC input 16 points GPL-D24A/D24C : DC input 32 points GPL-TR2A/TR2B/TR2C/TR2A1/TR2C1 : TR output 16 GPL-TR4A/TR4B/TR4C/TR4A1/TR4C1 : TR output 32 GPL-RY2A/R2C : Relay output 16 points GPL-DT4A/DT4B/DT4C/DT4A1/DT4C1 : DC input 16/ TR output 16 combo
③	Communication status indication LED	RUN LED It describes the status of power to be supplied to the system. • On : in case of normal power supply • Off : in case of abnormal power supply
		RDY LED • ON : when communication module is working normally.
		ERR LED • ON : when communication module is cut off.
④	self station no setting switch	The switch to set the node station no. of its own station. Available to set from 0~99 ('0 'station reserved) • X10 : 10 digits indicated • X1 : 1 digit indicated
⑤	I/O LED	It describes the contact status of I/O terminal.
⑥	Hook for DIN rail attachment	• Hook for DIN rail attachment
⑦	Terminal block	• Terminal block layout for I/O wiring * Refer to Art.3.3.

(2) Rnet module

(a) Stand-alone type module

No.	Item	Description		
①	Connection connector	Connector for communication connection with master/remote unit • 9 pin connector		
②	Smart I/O type name indication	• Describes Rnet module type name.		
			9 pin connector	5 pin D-sub connector
		DC input 16	GRL-D22A	GRL-D22A(N)/D22C
		DC input 32	GRL-D24A	GRL-D24A(N)/D24C
		TR output 16	GRL-TR2A	GRL-TR2A(N)/TR2C1/TR2C
		TR output 32	GRL-TR4A	GRL-TR4A(N)/TR4C1/TR4C
		Relay output 16	GRL-RY2A	GRL-RY2A(N)/RY2C
③	Communi- cation status indication LED	PWR LED It describes the status of power to be supplied to the system. • On : in case of normal power supply • Off : in case of abnormal power supply		
		TX LED It describes the transmission status of communication module. • Blink : when communication module is transmitting (except GRL-TR4A) • OFF : LED is OFF in the cases as follows ; ▶ in case that the voltage is not supplied normally to the basic unit. ▶ in case that the error to stop the operation is detected.		
		RX LED It describes the receiving status of communication module. • Blink : when communication module is receiving. • Off : when communication module has no receiving or the error is detected.		
④	self station no setting switch	The switch to set the node station no. of its own station. Available to set from 0~63. • X16 : 16 digits indicated • X1 : 1 digit indicated		
⑤	I/O LED	Describes the contact status of I/O terminal.		
⑥	Hook for DIN rail attachment	• Hook for DIN rail attachment		
⑦	Terminal block	• Terminal block layout for I/O wiring. * Refer to Art. 3.3.		

(b) Latch/Clear selectable module

No.	Item	Description
①	Connection connector	Connection connector for connecting with master/remote unit <ul style="list-style-type: none"> • 5 pin open type connector
②	Smart I/O type name indication	<ul style="list-style-type: none"> • Describes Rnet module type name GRL-D22A/D22C : DC input 16 GRL-D24A/D24C : DC input 32 GRL- TR2C /TR2C1 : TR output 16 GRL- TR4C/ /TR4C1 : TR output 32 GRL- RY2C : Relay output 16 GRL- DT4C /DT4C1 : DC input 16/TR output 16 combo
③	Communication status indication LED	PWR LED Indicates power status <ul style="list-style-type: none"> • On : Power is OK • Off : Power is not OK
		TXD LED Indicates TX status of communication module <ul style="list-style-type: none"> • Flicker : Now sending data • Off : Now not sending data
		RXD LED Indicates RX status of communication module <ul style="list-style-type: none"> • Flicker : Now receiving data • Off : Now not receiving data
④	self station no setting switch	The switch to set the node station no. of its own station. Available to set from 0~63. <ul style="list-style-type: none"> • X16 : 16 digits indicated • X1 : 1 digit indicated
⑤	I/O LED	Describes the contact status of I/O terminal.
⑥	Hook for DIN rail attachment	<ul style="list-style-type: none"> • Hook for DIN rail attachment
⑦	Terminal block	<ul style="list-style-type: none"> • Terminal block layout for I/O wiring. * Refer to Art. 3.3.
⑧	Mode change switch	<ul style="list-style-type: none"> • LATCH: In case of abnormal communication, hold the output • CLEAR: In case of normal communication, clear the status as 0

Remark

Latch/Clear function is provided in GRL-TR2C/TR2C1/TR4C/TR4C1/DT4C/DT4C1/RY2C module

(3) Snet module

No.	Item	Description
①	Connection connector	Connector for communication connection with master/remote unit • 9 pin connector
②	Smart I/O type name indication	<ul style="list-style-type: none"> • Describes Modbus module type name. GSL-D22A/D22C : DC input 16 GSL-D24A/D24C : DC input 32 GSL-TR2A/TR2C1/TR2C : TR output 16 GSL-TR4A/TR4C1/TR4C : TR output 32 GSL-RY2A/RY2C: Relay output 16 GSL-DT4A/DT4C1/DT4C : DC input 16 /TR output 16 combo
③	Communi- cation status indication LED	PWR LED It describes the status of power to be supplied to the system. • On : in case of normal power supply • Off : in case of abnormal power supply
		TX LED It describes the transmission status of communication module. • Blink : when communication module is transmitting (except for GRL-TR4A) • OFF : LED is OFF in the cases as follows ; ▶ in case that the voltage is not supplied normally to the basic unit. ▶ in case that the error to stop the operation is detected.
		RX LED It describes the receiving status of communication module. • Blink : when communication module is receiving. • Off : when communication module has no receiving or the error is detected.
④	self station no setting switch	The switch to set the node station no. of its own station. Available to set from 0~31. • X16 : 16 digits indicated • X1 : 1 digit indicated
⑤	I/O LED	It describes the contact status of I/O terminal.
⑥	Hook for DIN rail attachment	• Hook for DIN rail attachment
⑦	Terminal block	• Terminal block layout for I/O wiring * Refer to Art. 3.3.

(4) DeviceNet module

No.	Item	Description
①	Connection connector	Connector for communication connection with master/remote unit • 5 pin OPEN type connector
②	Smart I/O type name indication	• Describes DeviceNet module type name. GDL-D22A/D22C : DC input 16 GDL-D24A/D24C : DC input 32 GDL-TR2A/TR2C1/TR2C : TR output 16 GDL-TR4A/TR4C1/TR4C : TR output 32 GDL-RY2A/R2C: Relay output 16 GDL-DT4A/DT4C1/DT4C : DC input 16 /TR output 16 combo
③	Communication status indication LED	PWR LED It describes the status of power to be supplied to the system. • On : in case of normal power supply • Off : in case of abnormal power supply
		MS LED It describes interface status of communication module. • Green On: Normal completion of module initialization and device status • Green Blink: Communication waiting status after completion of initialization • Red On: Module hardware error • Off: Interface error
		NS LED It describes network status of communication module. • Green On: Device is operating and "online" status • Green Blink: Network offline status • Red On: Duplex station address error or "Bus Off" stats • Red Blink: module network is removed
④	self station no setting switch	The switch to set the node station no. of its own station. Available to set from 0~63. • X16 : 16 digits indicated • X1 : 1 digit indicated
⑤	I/O LED	It describes the contact status of I/O terminal.
⑥	Hook for DIN rail attachment	• Hook for DIN rail attachment
⑦	Terminal block	• Terminal block layout for I/O wiring * Refer to Art. 3.3.

* Dnet can be set as Normal mode, Quick mode and Dummy mode by using SyCon, nConfigurator which is software for XGT.

2) Modular type Smart I/O adapter module (Pnet, Dnet, Rnet, Enet)

(1) Form of Pnet module (Modular type) and name of each part

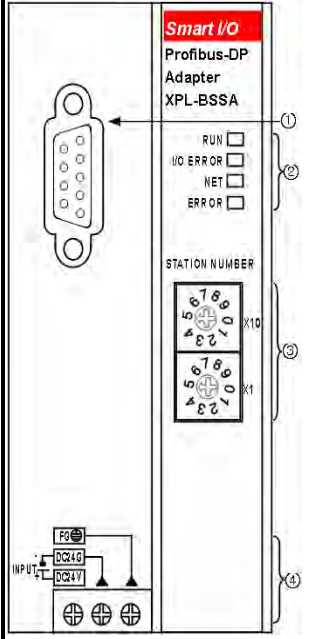
Name of each part	Purpose			
	① Connector for communication connection Communication cable connection connector for 9 pin plug			
	② Communication status indication			
	Name	LED status	LED indication contents	
	RUN (Yellow Green)	Module status indication of Pnet I/F adapter		
		On	Normal	On during communication
		Off	error	Heavy trouble
	Flicker	-	1) communication waiting status	
			2) when self-diagnosis	
			3) When cable is dropped after RUN LED is On	
			4) When I/O module is removed after RUN LED is On	
5) In case that I/O module is not equipped				
6) In case that I/O point exceeds the allowed value				
7) In case that I/O module No. exceeds the allowed value				
I/O ERROR (RED)	Indicates the interface status between Pnet I/F adapter and I/O module.			
Off	Normal	Normal		
On	error	When there is no response in I/O module		
		1) When I/O module is removed		
		2) When an error occurs in the I/O module		
NET (Yellow Green)	Indicates when sending/receiving the data between master and Pnet I/F adapter			
On	Normal	1) indicates sending/receiving the data		
		2) When master's system configuration is different from Pnet I/F adapter's extension I/O module configuration. (At this time, RDY LED is On)		
Off	-	Indicate when there is no transmission		
ERROR (RED)	Indicates when data transmission between master and Pnet I/F adapter is stopped.			
On	Error	1) indicates when there is no transmission		
		2) When master system configuration is different from Pnet I/F adapter's I/O module configuration (At this time, RDY LED is On)		
Off	Normal	Indicates data transmission.		
③ station address setting switch				
×10 : 10 digits indication				
× 1 : 1 digit indication				
④ External supply power input terminal				
24V : DC 24V(+) power input terminal				
24G : DC 24V(-) power input terminal				
FG : frame ground terminal				

(2) Form of Dnet module (Modular type) and name of each part

Name of each part	No.	Name	purpose			
	①	Connection connector	Connector for communication connection between master and remote module • 5 pin open type connector			
	②	Communication status LED	RUN	Yellow	Power status of Dnet adapter	
				Green	On	Normal module operating power supply status
				Off	Heavy trouble	
			IO ERROR	RED	On	Interface status between Dnet adapter and I/O module In case that there is no response in the I/O module. 1) When I/O module is removed 2) When error occurs in the I/O module
					Off	I/O module normal status
			MS	Yellow Green	On	Dnet adapter's module status Normal completion of module initialization and device status
					Flicker	Communication waiting status after completion of initialization (waits checking the duplicated station address)
				RED	On	Error status of module hardware 1) When exceeding the allowed range of I/O module 2) When I/O module is removed 3) When error occurs in the I/O module 4) When exceeding the I/O allowed point
					NS	Yellow Green
			Off	Device is not "online" status. 1) Not completion of checking the duplicated station address. 2) Not supporting the module power (At this time, MS is also Off)		
			RED	On		Device is operating, It is already "online" status but network is not connected.
				Flicker		1) Duplex station address error 2) Network is "Bus Off" stats
					On	Device is "Time Out" status (module network is removed)
					Flicker	
③	Self station address setting switch	Switch for setting self station address (setting range of 0~63) • X10 : 10 digits indication • X1 : 1 digit indication				
④	Mode switch	• No. 1 pin(On) : O/S download mode • No. 2 pin(On) : Quick mode * Quick mode: reduces the initial communication connection time (when supplying master module, it can be done within Max. 1.5s)				
⑤	Download terminal unit	• Terminal unit for downloading the O/S				
⑥	Power terminal unit	• External supply power input terminal 24V: DC 24V(+) power input terminal 24G: DC 24V GND terminal				

(3) Form of Rnet module (Modular type) and name of each part

Name of each part	No.	Name	purpose			
	①	Connection connector	Connector for communication connection between master and remote module • 5 pin open type connector			
	②	Communication status LED	Name	status Contents		
			RUN	Power status of Rnet adapter		
				On	Normal module operating power supply status	
			Off	Heavy trouble		
			Flicker	1) Ready status 2) Self diagnosis 3) Cable is removed after RUN LED is on. 4) I/O module is removed after RUN LED is on. 5) I/O module is not installed 6) I/O points exceed the limit 7) The number of I/O module exceeds the limit		
				IO ERROR	Interface status between Rnet adapter and I/O module	
					On	1) There's no response from I/O module 2) I/O module is removed 3) Error occurs in I/O module
					Off	I/O module is normal
				TX/RX	Now sending/receiving data to master	
					Flicker	Now sending data
	Off	Now there's no data transmission				
LATCH	Indicates data output mode in case of communication error					
	On	Operate as latch mode				
	Off	Operate as clear mode				
③	Self station address setting switch	Switch for setting self station address (setting range of 0~63) • X10 : 10 digits indication • X1 : 1 digit indication				
④	Power terminal unit	• Input terminal of external power supply 24V: DC 24V(+) power input terminal 24G: DC 24V GND terminal				
⑤	Cover	Remove when setting mode switch				
⑥	Mode switch	Sets data output mode incase of communication error				

Remark

1. How to set mode switch
 - 1) Eliminate cover⑤.
 - 2) When mode switch⑥ is on (in left side), it is set as Clear mode.
 - 3) When mode switch⑥ is off (in right side), it is set as Latch mode.
2. Output value according to mode switch
 - 1) Latch mode: In case of communication error, holds present value
 - 2) Clear mode: In case of communication error, set output value as '0'
3. Mode switch should be set when power is off.

(4) Form of Enet module (Modular type) and name of each part
 (a) XEL-BSSA

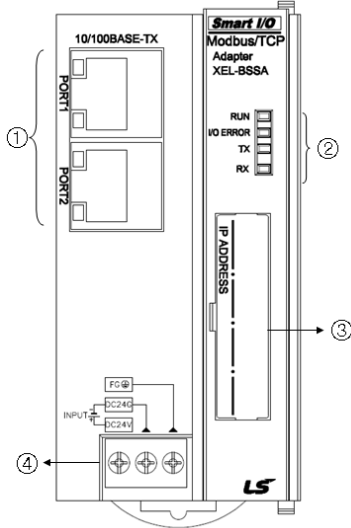
Name of each part	No.	Name	purpose			
	①	Connection connector	RJ-45 2Port			
	②	Communication status LED	Name	Color	Status	Contents
	RUN	Yellow Green	On	Indicates operating status of adapter module		
			Off	Power on and CPU normal		
			Off	Power off and CPU abnormal		
	I/O ERROR	RED	On	Interface status between IO module and adapter		
			Off	When IO module is removed		
			Off	When error occurs in IO module		
	TX	Yellow Green	Flicker	Indicates transmitting data to master module		
			Off	Transmitting the data		
		Off	There is no transmission			
RX	Yellow Green	Flicker	Indicates receiving data from master module			
		Off	Receiving data			
		Off	There is no reception			
③	IP address plate	Writes down IP address of module				
④	Power terminal block	<ul style="list-style-type: none"> Input terminal for external power supply 24V: DC 24V(+) power input terminal 24G: DC 24V GND terminal 				

(b) XEL-BSSB

Name of each part	No.	Name	purpose				
	①	Connection connector	RJ-45 2Port				
	②	Communication status LED	Name	Color	Status	Contents	
			RUN	RUN	On	Indicates operating status of adapter module	
					Off	Power on and CPU normal	
					Off	Power off and CPU abnormal	
			I/O ERROR	IO ERROR	On	Interface status between IO module and adapter	
						When IO module is removed	
						When there is no response from IO module	
			MS	Yellow Green	On	When communication module is removed during communication	
					Flicker	IO module normal status	
					Indicates module status		
			NS	RED	On	Normal	
					Flicker	When device setting is not complete (In case of Input Only, Normal)	
					When non-restorable error occurs		
			MS	Yellow Green	On	When abnormal setting or restorable error occurs	
Flicker	When non-restorable error occurs						
When abnormal setting or restorable error occurs							
NS	Yellow Green	On	Indicates network status				
		Flicker	When there is at least one connection with device				
		There is no connection with device					
RED	RED	On	Duplicated IP address is detected				
		Flicker	Time-out with more than one device occurs				
③	IP address plate	Writes down IP address of module					
④	Power terminal block	<ul style="list-style-type: none"> Input terminal for external power supply 24V: DC 24V(+) power input terminal 24G: DC 24V GND terminal 					

3.3 I/O Wiring Diagram of Communication Module

3.3.1 External connection diagram of Smart I/O module

1) Profibus-DP module

(1) Terminal block configuration

Terminal block	Contact and Power Input	
GPL-D22A GPL-D22C / GPL-D24A GPL-D24C	0 ~ 15	Input contact terminal (GPL-D22A)
	0 ~ 31	Input contact terminal (GPL-D24A)
	COM	Common terminal (16 points COM)(GPL-D22A)
	COM0/COM1	Common terminal (16 points COM)(GPL-D24A)
	FG	FG terminal
	DC 24V	DC 24V(+) power input terminal
	DC 24G	DC 24V(-) power input terminal
GPL-DT4A GPL-DT4B GPL-DT4C GPL-DT4A1 GPL-DT4C1	0 ~ 15/0 ~ 15	I/O contact terminal
	COM0/COM1	Common terminal (16 points COM)
	FG	FG terminal
	DC 24V	DC 24V(+) power input terminal
	DC 24G	DC 24V(-) power input terminal
GPL-TR2A/B/C GPL-TR2A1 GPL-TR2C1 / GPL-TR4A/B/C GPL-TR4A1 GPL-TR4C1	0 ~ 15	Output contact terminal (GPL-TR2A)
	0 ~ 31	Output contact terminal (GPL-TR4A)
	COM	Common terminal (16 points COM)(GPL-TR2A)
	COM0/COM1	Common terminal (16 points COM)(GPL-TR4A)
	FG	FG terminal
	24V	DC 24V(+) power input terminal
	24G	DC 24V(-) power input terminal
GPL-RY2A GPL-RY2C	0 ~ 15	Output contact terminal
	COMA~COMD	Common terminal (8 points COM)
	FG	FG terminal
	DC 24V	DC 24V(+) power input terminal
	DC 24G	DC 24V(-) power input terminal
GPL-AV8C GPL-AC8C GPL-DV4C GPL-DC4C	CH0~7 V+/I+	CH0~7 V+/I+ input terminal
	CH0~7 V-/I-	CH0~7 V-/I- input terminal
	DC24V	DC 24V(+) power input terminal
	DC24G	DC 24V(-) power input terminal
	N.C	N.C

2) Wiring Diagram

Item	Wiring diagram		
DC input module	<p>[GPL-D22A/D22C]</p>	<p>[GPL-D24A/D24C]</p>	<p>[GPL-DT4A/B/C/A1/C1]</p>
TR output	<p>[GPL-TR2A/TR2A1/TR2C1]</p>	<p>[GPL-TR4A/TR4A1/TR4C1]</p>	<p>[GPL-DT4A/DT4A1/DT4C1]</p>
	<p>[GPL-TR2B/TR2C]</p>	<p>[GPL-TR4B/TR4C]</p>	<p>[GPL-DT4B/DT4C]</p>

Item	Wiring diagram
Relay output	<p data-bbox="360 357 584 388">[GPL-RY2A/Ry2C]</p> <p data-bbox="350 776 1020 836">* Between COMA and COMB are connected internally and also between COMC and COMD are connected internally.</p>
Analog input	<p data-bbox="350 855 485 885">[GPL-AV8C]</p>
	<p data-bbox="350 1354 485 1385">[GPL-AC8C]</p>

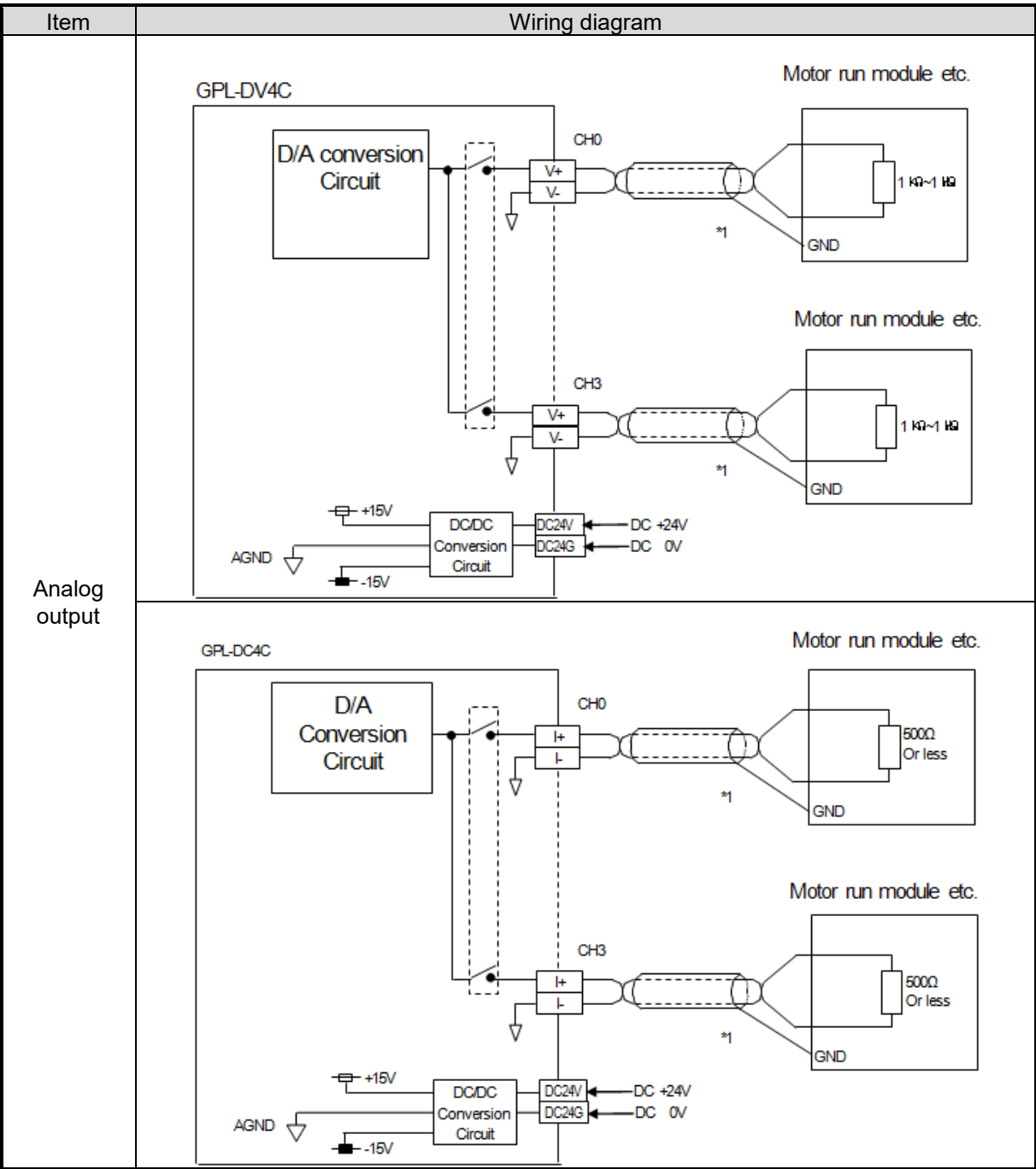

2) DeviceNet module

(1) Terminal block configuration

Terminal block		Contact and Power Input
GDL-D22A/C / GDL-D24A/C	0 ~ 15	Input contact terminal(GDL-D22A)
	0 ~ 31	Input contact terminal(GDL-D24A)
	COM	Common terminal(16 points COM)(GDL-D22A)
	COM0/COM1	Common terminal(16 points COM)(GDL-D24A)
GDL-DT4A/B/C GDL-DT4A1/C1	0 ~ 15/0 ~ 15	I/O contact terminal
	COM0/COM1	Common terminal(16 points COM)
GDL-TR2A/B/C GDL-TR2A1/C1 / GDL-TR4A/B/C GDL-TR4A1/C1	0 ~ 15	Output contact terminal(GDL-TR2A)
	0 ~ 31	Output contact terminal(GDL-TR4A)
	COM	Common terminal(16 points COM)(GDL-TR2A)
	COM0/COM1	Common terminal(16 points COM)(GDL-TR4A)
GDL-RY2A GDL-RY2C	0 ~ 15	Output contact terminal
	COMA~COMD	Common terminal(8 points COM)

(2) Wiring diagram

Item	Wiring diagram		
DC input module	[GDL-D22A/D22C]	[GDL-D24A/D24C]	[GDL-DT4A/B/C/A1/C1]

Item	Wiring diagram
TR output	<p>[GDL-TR2A/TR2A1/TR2C1] [GDL-TR4A/TR4A1/TR4C1] [GDL-DT4A/DT4A1/DT4C1]</p>
	<p>[GDL-TR2B/TR2C] [GDL-TR4B/TR4C] [GDL-DT4B/DT4C]</p>
	<p>[GDL-RY2A/R2C]</p> <p>* Between COMA and COMB are connected internally and also between COMC and COMD are connected internally.</p>

3) Rnet module

(1) Terminal block configuration

Terminal block		Contact and Power Input
GRL-D22A/D24A GRL-D22C/D24C	0 ~ 15	Input contact terminal (GRL-D22A)
	0 ~ 31	Input contact terminal (GRL-D24A)
	COM	Common terminal (16 points COM)(GRL-D22A)
	COM0/COM1	Common terminal (16 points COM)(GRL-D24A)
	FG	FG terminal
	DC 24V	DC 24V(+) power input terminal
	DC 24G	DC 24V(-) power input terminal
GRL-DT4A GRL-DT4C1	0 ~ 15/0 ~ 15	I/O contact terminal
	COM0/COM1	Common terminal (16 points COM)
	FG	FG terminal
	DC 24V	DC 24V(+) power input terminal
	DC 24G	DC 24V(-) power input terminal
GRL-TR2A/TR4A GRL-TR2C1/TR4C1	0 ~ 15	Output contact terminal (GRL-TR2A)
	0 ~ 31	Output contact terminal (GRL-TR4A)
	COM	Common terminal (16 points COM)(GRL-TR2A)
	COM0/COM1	Common terminal (16 points COM)(GRL-TR4A)
	FG	FG terminal
	24V	DC 24V(+) power input terminal
	24G	DC 24V(-) power input terminal
GRL-RY2A/R2C	0 ~ 15	Output contact terminal
	COMA~COMD	Common terminal (8 points COM)
	FG	FG terminal
	DC 24V	DC 24V(+) power input terminal
	DC 24G	DC 24V(-) power input terminal

(2) Wiring diagram

Item	Wiring diagram		
DC input module	<p>[GRL-D22A(N)/D22C]</p>	<p>[GRL-D24A(N)/D24C]</p>	<p>[GRL-DT4A(N)/DT4C(input)]</p>
	TR output module	<p>[TR2A(N)/TR2C1]</p>	<p>[TR4A(N)/TR4C1]</p>
<p>[GRL-TR2C]</p>		<p>[GRL-TR4C]</p>	<p>[GRL-DT4C(output)]</p>

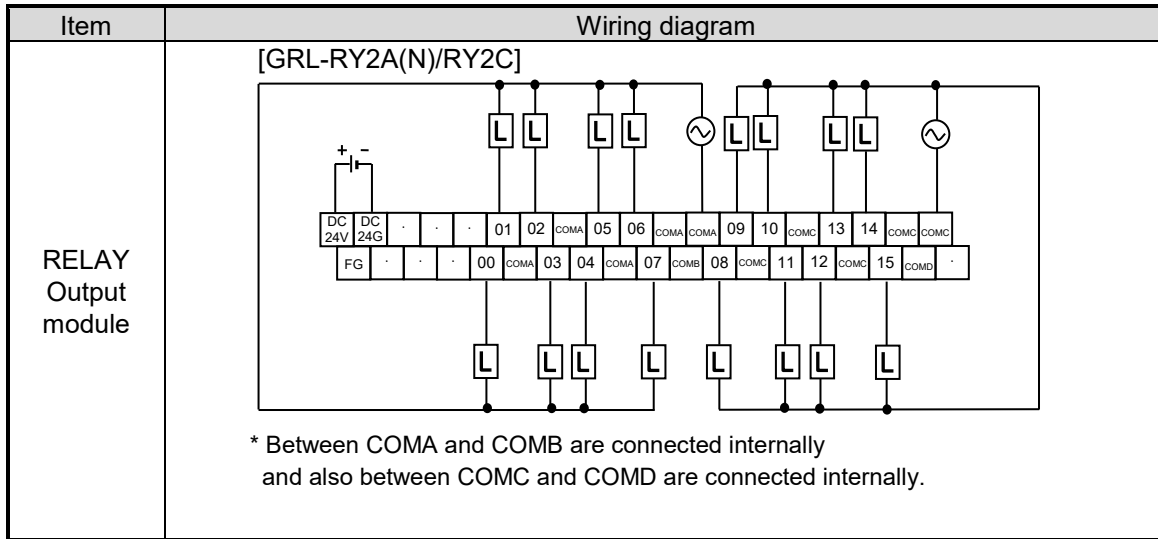

4) Snet module

(1) Terminal block configuration

Terminal block		Contact and Power Input
GSL-D22A/D24A GSL-D22C/D24C	0 ~ 15	Input contact terminal(GSL-D22A)
	0 ~ 31	Input contact terminal(GSL-D24A)
	COM	Common input(16 points COM)(GSL-D22A)
	COM0/COM1	Common input(16 points COM)(GSL-D24A)
	FG	FG terminal
	DC 24V	DC 24V(+) power input terminal
	DC 24G	DC 24V(-) power input terminal
GSL-DT4A GSL-DT4C1	0 ~ 15/0 ~ 15	I/O contact terminal
	COM0/COM1	Common terminal(16 points COM)
	FG	FG terminal
	DC 24V	DC 24V(+) power input terminal
	DC 24G	DC 24V(-) power input terminal
GSL-TR2A/TR4A GSL-TR2C1/TR4C1	0 ~ 15	Output contact terminal(GSL-TR2A)
	0 ~ 31	Output contact terminal(GSL-TR4A)
	COM	Common terminal(16 points COM)(GSL-TR2A)
	COM0/COM1	Common terminal(16 points COM)(GSL-TR4A)
	FG	FG terminal
	24V	DC 24V(+) power input terminal
	24G	DC 24V(-) power input terminal
GSL-RY2A/R2C GSL-RY2C	0 ~ 15	Output contact terminal
	COMA~COMD	Common terminal(8 points COM)
	FG	FG terminal
	DC 24V	DC 24V(+) power input terminal
	DC 24G	DC 24V(-) power input terminal

(2) Wiring diagram

Item	Wiring diagram		
DC input module	<p>[GSL-D22A]</p>	<p>[GSL-D24A]</p>	<p>[GSL-DT4A(input)]</p>
	TR output module	<p>[GSL-TR2A/TR2C1]</p>	<p>[GSL-TR4A/TR4C1]</p>
<p>[GSL-TR2C]</p>		<p>[GSL-TR4C]</p>	<p>[GSL-DT4C(output)]</p>

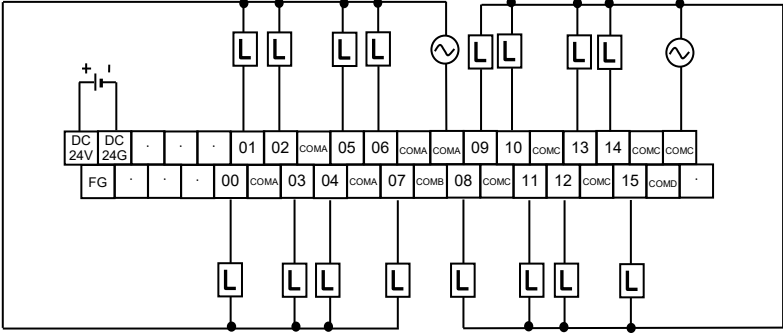
Item	Wiring diagram
RELAY output module	<p data-bbox="404 376 561 404">[GSL-RY2A/C]</p>  <p data-bbox="404 776 1077 831">* Between COMA and COMB are connected internally and also between COMC and COMD are connected internally.</p>

5) RAPIEnet module

(1) Terminal block configuration

Terminal block		Contact and Power Input
GEL-D24C	0 ~ 31	Input contact terminal(GSL-D24A)
	COM0/COM1	Common input(16 points COM)(32points)
	FG	FG terminal
	DC 24V	DC 24V(+) power input terminal
	DC 24G	DC 24V(-) power input terminal
GEL-DT4C1	0 ~ 15/0 ~ 15	I/O contact terminal
	COM0/COM1	Common terminal(16 points COM)
	FG	FG terminal
	DC 24V	DC 24V(+) power input terminal
	DC 24G	DC 24V(-) power input terminal
GEL-TR4C1	0 ~ 15	Output contact terminal(16points)
	0 ~ 31	Output contact terminal(32points)
	COM	Common terminal(16 points COM)(16points)
	COM0/COM1	Common terminal(16 points COM)(32points)
	FG	FG terminal
	24V	DC 24V(+) power input terminal
	24G	DC 24V(-) power input terminal
GEL-RY2C	0 ~ 15	Output contact terminal
	COMA~COMD	Common terminal(8 points COM)
	FG	FG terminal
	DC 24V	DC 24V(+) power input terminal
	DC 24G	DC 24V(-) power input terminal
GEL-AV8C GEL-AC8C GEL-DV4C GEL-DC4C	CH 0~7 V+/I+	CH 0~7 V+/I+ input terminal
	CH 0~7 V-/I-	CH 0~7 V-/I- input terminal
	DC 24V	DC 24V(+) power input terminal
	DC24G	DC 24V(-) power input terminal
	N.C	N.C

(2) Wiring diagram

Item	Wiring diagram	
DC input module	<p style="text-align: center;">[GEL-D24C]</p>	<p style="text-align: center;">[GEL-DT4C1(input)]</p>
TR output module	<p style="text-align: center;">[GEL-TR4C1]</p>	<p style="text-align: center;">[GEL-DT4C1(output)]</p>

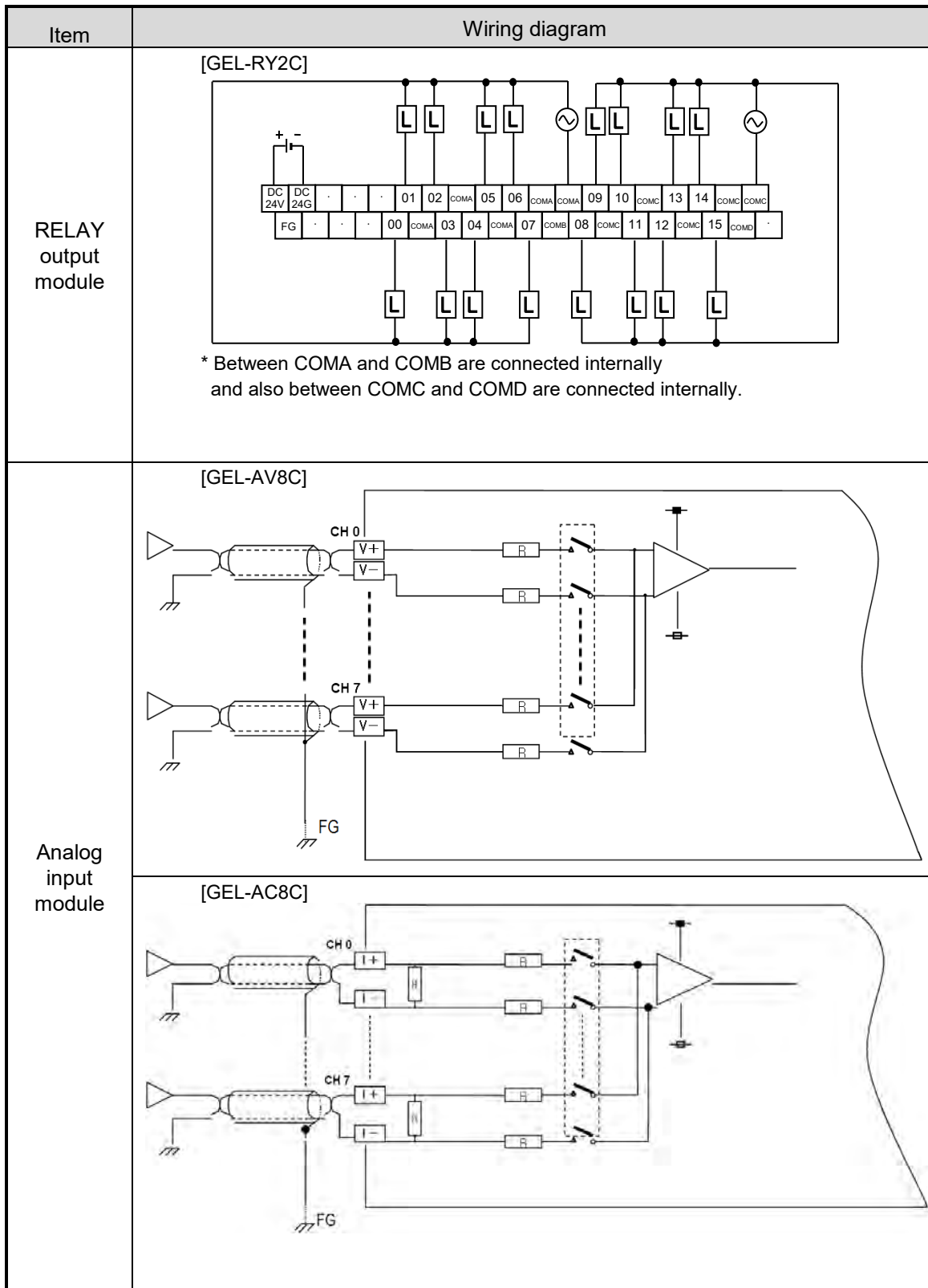

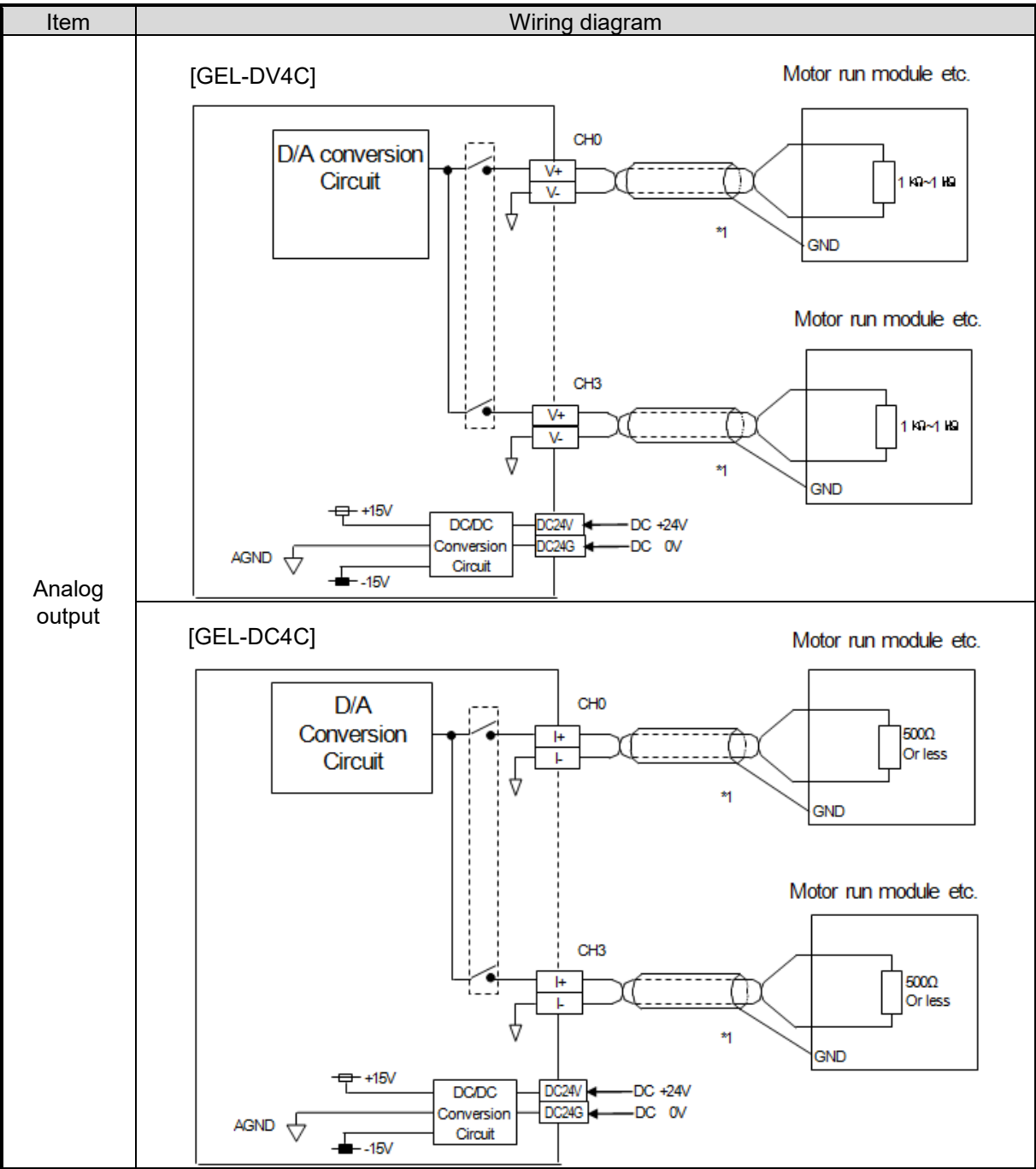

3.4 Examples of System Configuration

3.4.1 Profibus-DP System

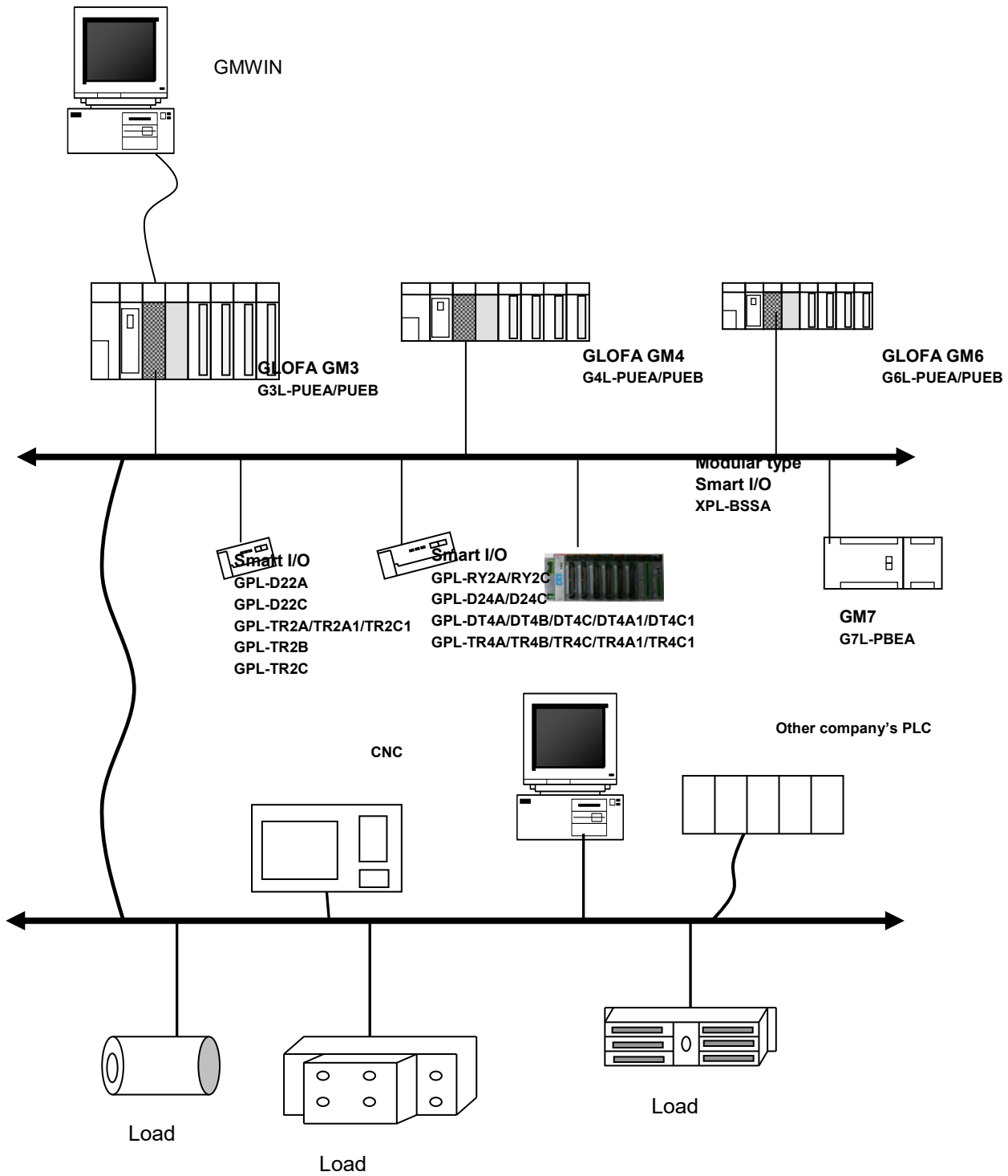

3.4.2 DeviceNet System

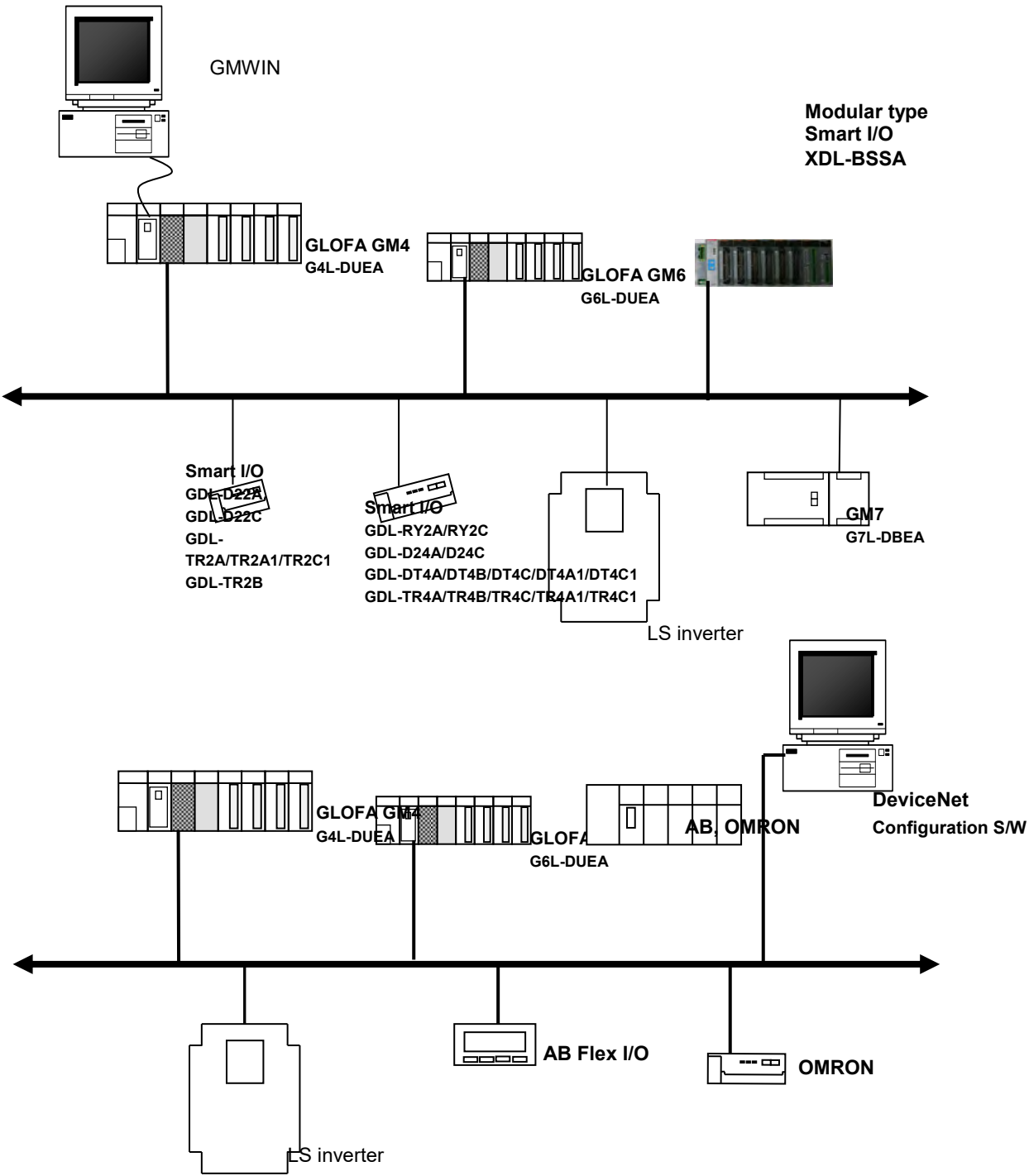

3.4.3 Rnet System

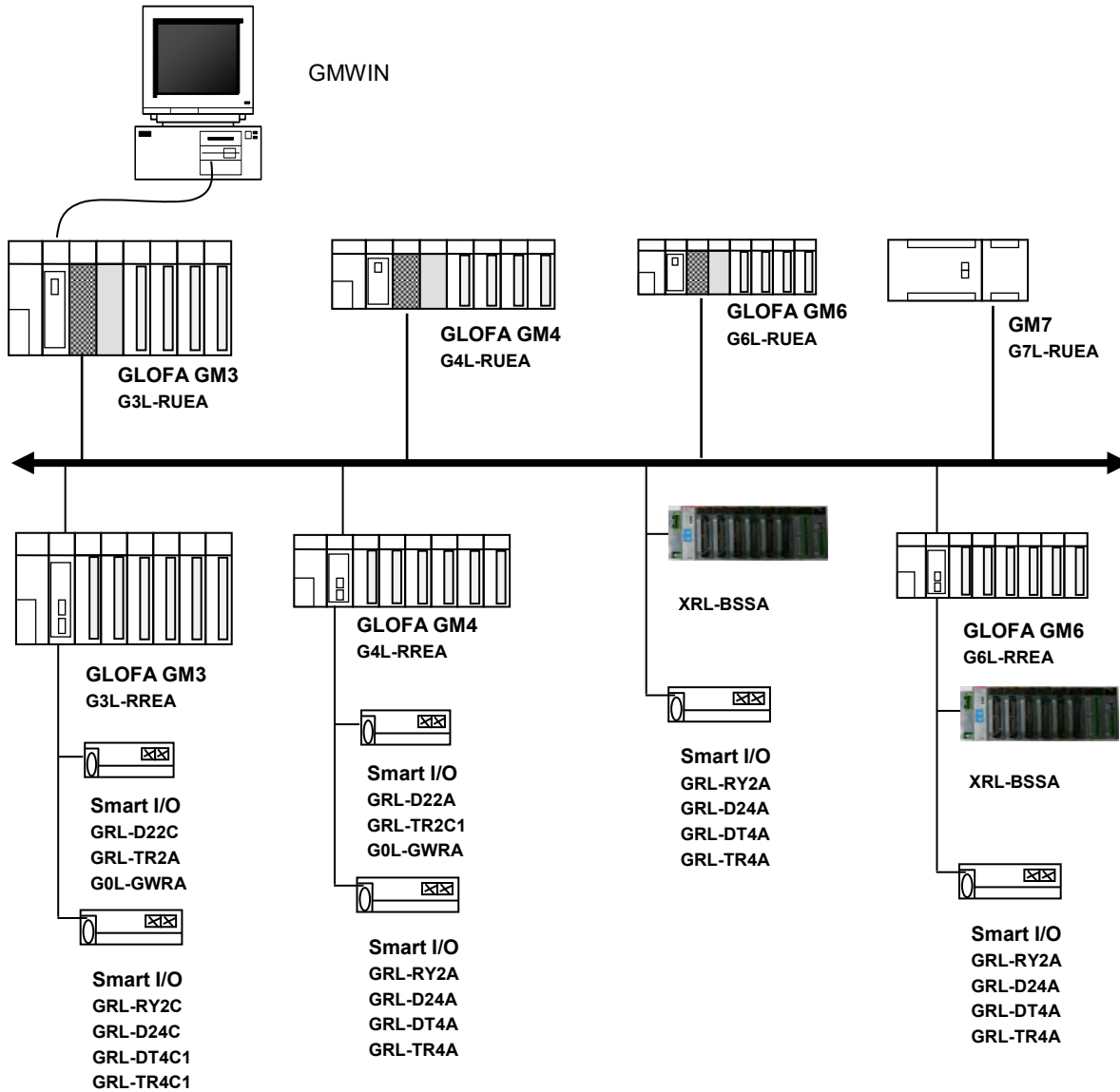

3.4.4 Snet System

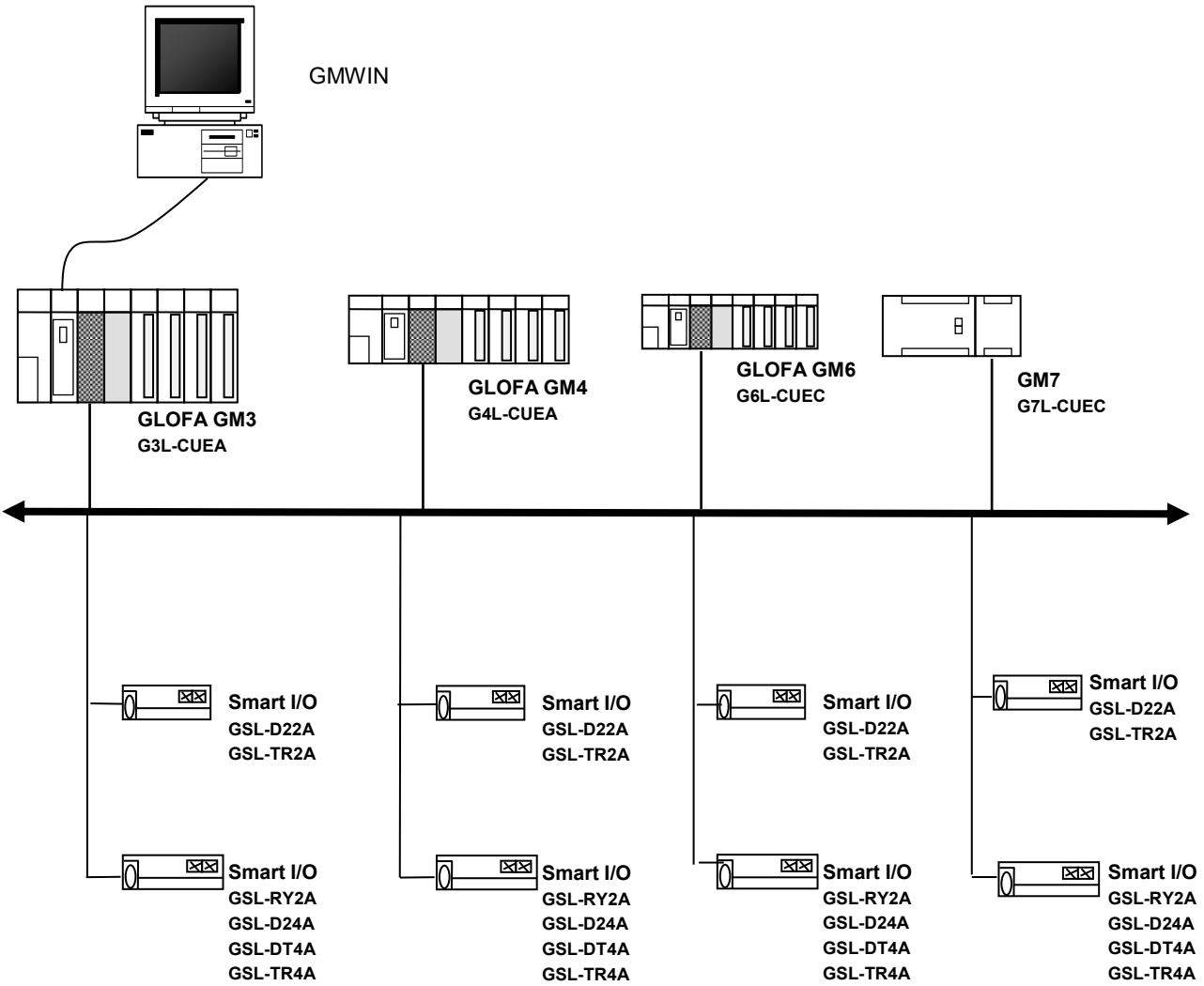

3.4.5 RAPIenet System

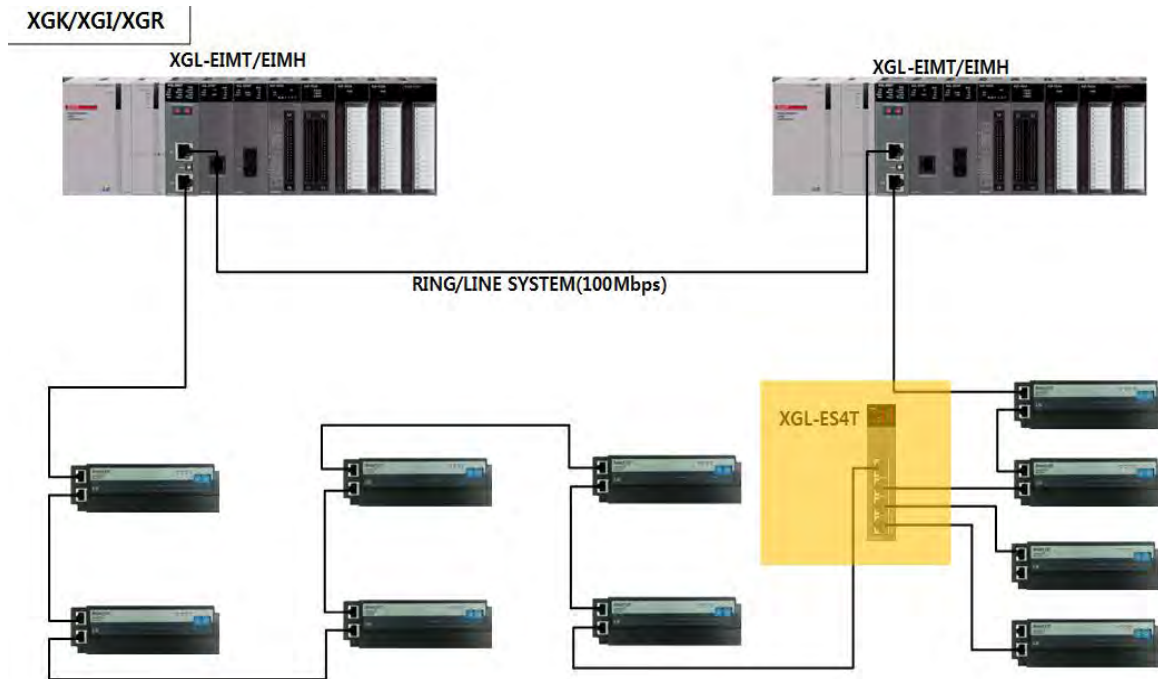

Chapter 4 Communication Programming

4.1 Overview

There are two kinds of Programming methods in using the Smart I/O series.
For further information, please refer to the user's manual related to "Master module".

4.1.1 High-speed Link

High-speed Link is used when other station's data or information is periodically exchanged at every specific time. By referring to the changing data of its own station or other station periodically, it enables to utilize the data to the system effectively and communicates by setting the simple parameter.

The setting method for GLOFA series is to designate its own area and the area of other station to send or receive and data size, station no. in GMWIN parameter setting (for MASTER-K, in KGLWIN parameter setting) and then carry out communication. Data size is at least 1 word (16 points) for communication and Rnet communication is available up to 3,840 words. The communication period is available to set max. 20ms up to 10 sec according to the communication contents.

As it is available to communicate with other station by simple parameter setting, it is easy to use this program and the High-speed process of internal data enables to process lots of data at the same time periodically.

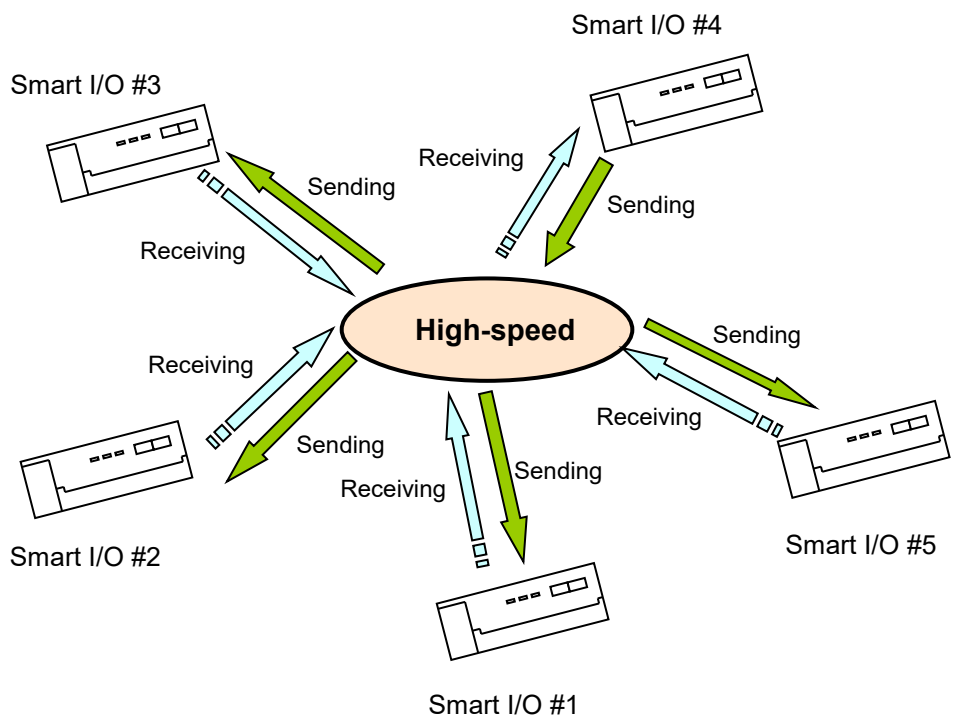

4.1.2 Function Block (GLOFA-GM) / Instruction (MASTER-K)

High-speed Link is periodic communication, but communication by *Function Block/Instruction* is the service to communicate when the specific event to communicate with other station occurs. In case that the error occurs in other station which results in sending this content to other other station or when specific contact is entered to communicate, it is available to use *Function Block/Instruction*.

The program method is written by designating Enable condition, communication module installed module position, station no., data area of its own station and the area of other station using *Function Block* per type made by GMWIN program mode for GLOFA series (by KGLWIN program mode for MASTER-K series) in advance and Instruction.

Data size to communicate in *High-speed Link* is word (16 points) unit but in GLOFA Function Block, it is available to communicate with each other station per data type such as Bit, Byte, and Word etc. and in MASTER-K, also by Word unit.

Difference between *High-speed Link* operation and the operation by Function Block/Instruction

Contents	<i>High-speed Link</i>	Function Block/Instruction
Basic unit of TX/RX data	1word (16 points)	GLOFA : available per data type (Bit, Byte, Word etc.) MASTER-K: supports only Word type.
Communication period	20ms(per scan) ~ 10sec	Performs whenever Enable condition of communication program starts.
Operation method	Parameter setting→Download to PLC→ <i>High-speed Link</i> Enable→run	GLOFA : Compile→ Download to PLC→Run MASTER-K : Download to PLC→Run
Control by CPU operation mode key	<i>High-speed Link is performed regardless of the CPU states (RUN, STOP, PAUSE)</i>	Performs the operation following to the key condition of CPU module.

Remark

- 1) *High-speed Link* service is used only for Profibus-DP, DeviceNet, Rnet, RAPIEnet series from Smart I/O series. Configuration tool to operate the corresponding module is provided separately.
- 2) Function Block service is used for Modbus communication programming and for further information. Refer to the user's manual.

4.2 High-speed Link

4.2.1 Overview

High-speed Link is a communication service which transmits data by setting parameter (TX/RX size, period of TX/RX, area of TX/RX and storage).

- Setting *High-speed Link* block:

- (1) In case that there are several areas for sending/receiving, it is available to set max.64 block (32 for sending, 32 for receiving) respectively.
- (2) Available to set 60 words per block.
- (3) Available to use 3,840 words for max. link point.

- TRX period setting function:

As the user can set sending/receiving period per each block, it is available to set the sending/receiving period from 20ms (every scan) to 10 sec. dividing into the area which needs especially rapid sending/receiving and the area not needed.

- TRX area setting:

It is available to set sending/receiving area per data block according to setting I/O address.

- *High-speed Link* information provision function:

By providing the user with *High-speed Link* information by the user keyword, it enables to build reliable communication system easily.

Maximum *High-speed Link* points according to device type (master standard)

Classification		Max. communication point (word)	Max. sending point (word)	Max. block no.	Max. point per block (word)	Remark
Smart I/O series	G3/4/6/7L-RUEA	3,840	1,920	64(0-63)	60	Rnet I/F Module
	G3/4/6L-PUEA/PUEB	1,792	1,792	64(0-63)	60	Pnet I/F Module
	G4/6L-DUEA	128	128	64(0-63)	60	Dnet I/F Module
	XGL-EIMT/H	12,800	12,800	64(0-63)	200	RAPIenet I/F Module

4.2.2 High-speed Link TRX Data Processing

TRX data processing in *High-speed Link* can be described as follows.

Ex) This is an example to send/receive data from local master (0 station) to Smart I/O station. This is a map to send/receive data from/to the corresponding remote station when output module is allocated by 1, 2, 3 station respectively and input module is set as 4, 5, 6 station. The address, sending/receiving period, data size of Smart I/O station is as follows.

High-speed Link parameters have 32 blocks no. for sending and 32 blocks no. for receiving to send/receive the data. Also, Block no. can be assigned and used from 0 to 63 for sending/receiving. Generally, when sending the data, the sender is required to determine data to read and block number to send without designating the no. of other stations. But in case it is set by the remote (for example: Smart I/O series), the user is required to determine the station no. of Remote station (node) and block no. to send, and data sending/receiving mode for the remote station.

The following is an example of sending/receiving parameter setting for Smart I/O series that is composed of input modules and output modules. This sends/receives the data from master that tries to access Smart I/O module to each remote station. The block no. data address, communication period, and data size of the corresponding module from local GMWIN or KGLWIN shall be set in *High-speed Link* parameter. In this case, you should pay attention that the block no. should be different regardless of I/O module in order to send/receive the desired data.

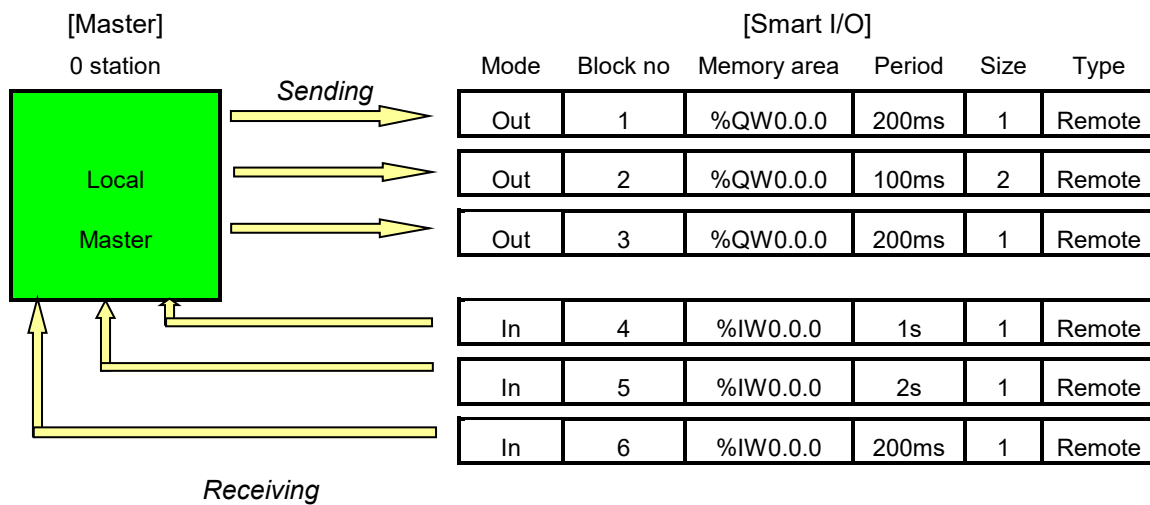

4.2.3 Operation Order by High-speed Link

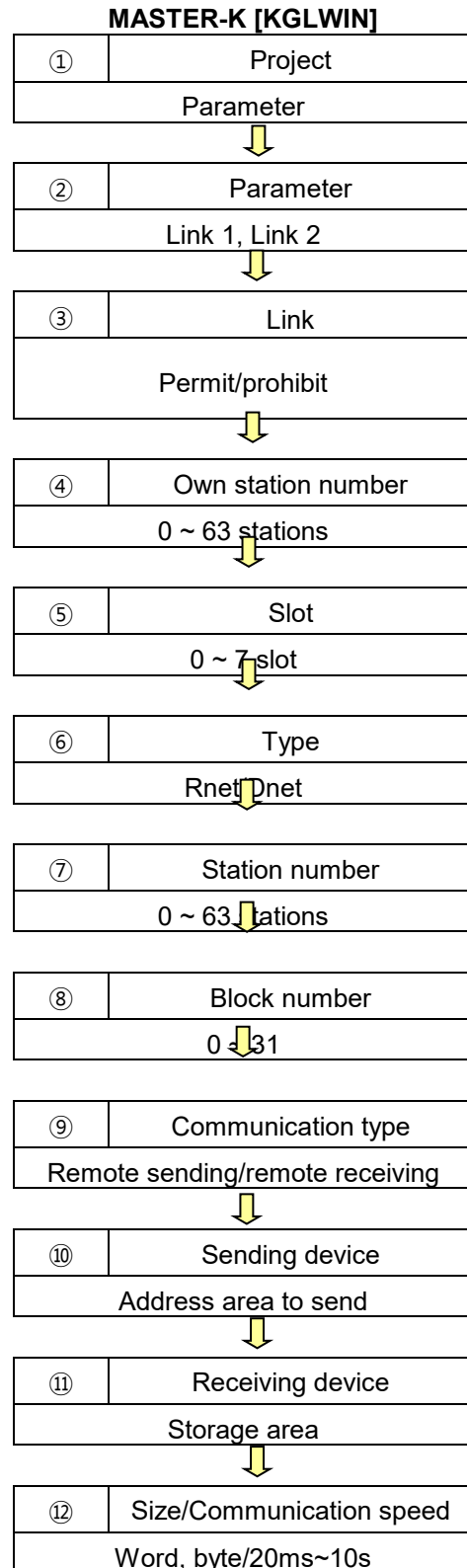
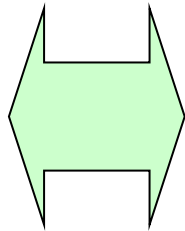
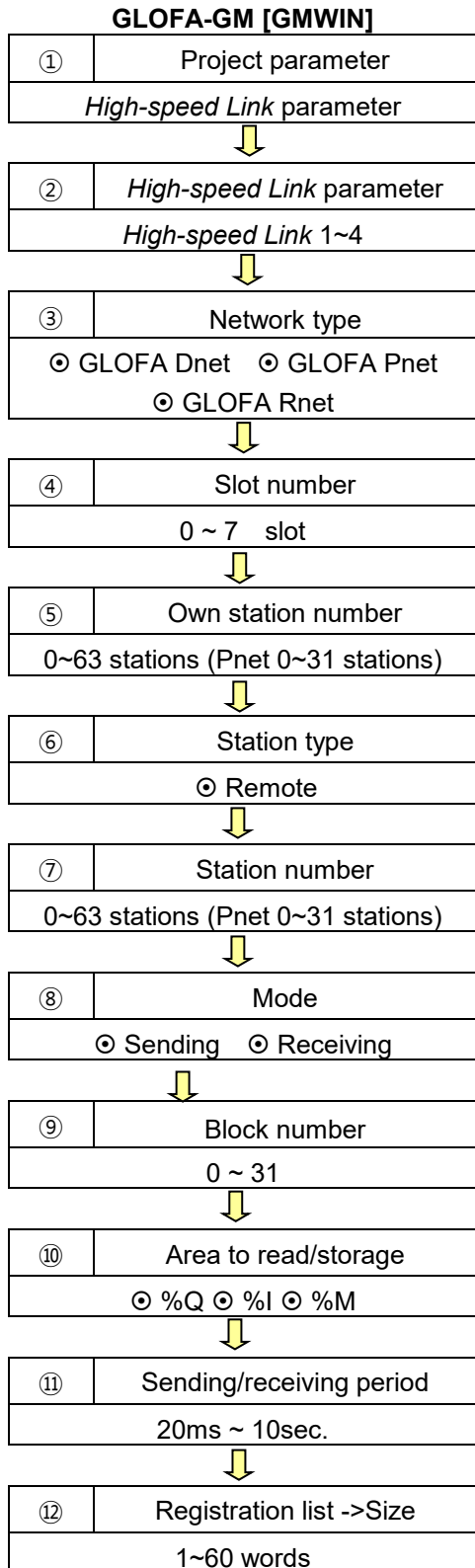

4.2.4 GMWIN's Setting of *High-speed Link* Parameter

High-speed Link parameter selects link parameter from GMWIN project menu and sets the corresponding item. The setting order and the function per item are shown as follows.

(1) *High-speed Link* Project Setting

If selecting *High-speed Link* parameter from GMWIN project basic screen below, it shows the *High-speed Link* parameter basic screen and the user can select the corresponding item.

GMWIN Project Basic Screen

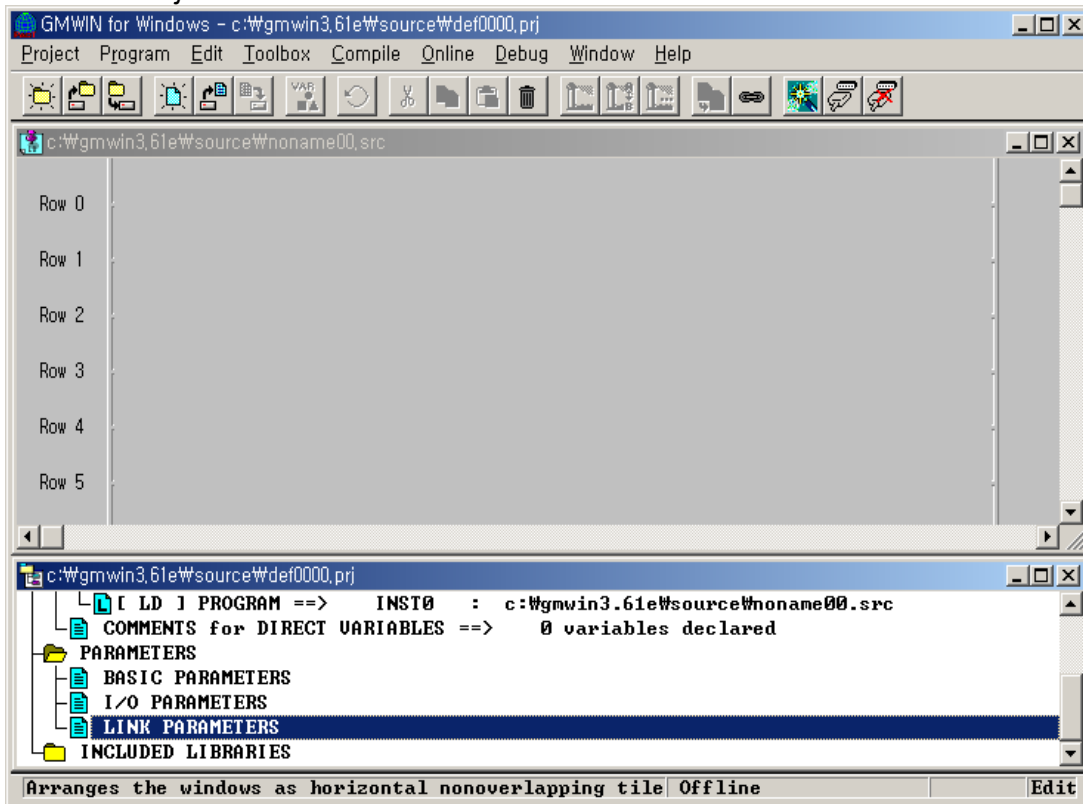

(2) Link Parameter Selection

(a) Setting method: select parameter-*High-speed Link* parameter from project screen.

GMWIN *High-speed Link* Parameter

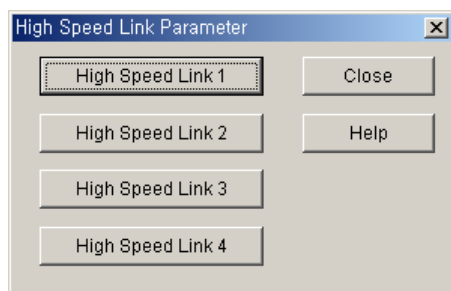

(b) Setting function: GMWIN *High-speed Link* 1~4 items means max.installation no. of communication module by master PLC CPU type.

- 1) If communication model used is only one, select *High-speed Link 1*.
- 2) One *High-speed Link* parameter is available to set only for one communication module.

(3) Link Parameter Setting

If selecting the corresponding parameter from parameter setting basic screen, *High-speed Link* parameter setting window will appear and when setting the parameter first, the initial value will be indicated as below.

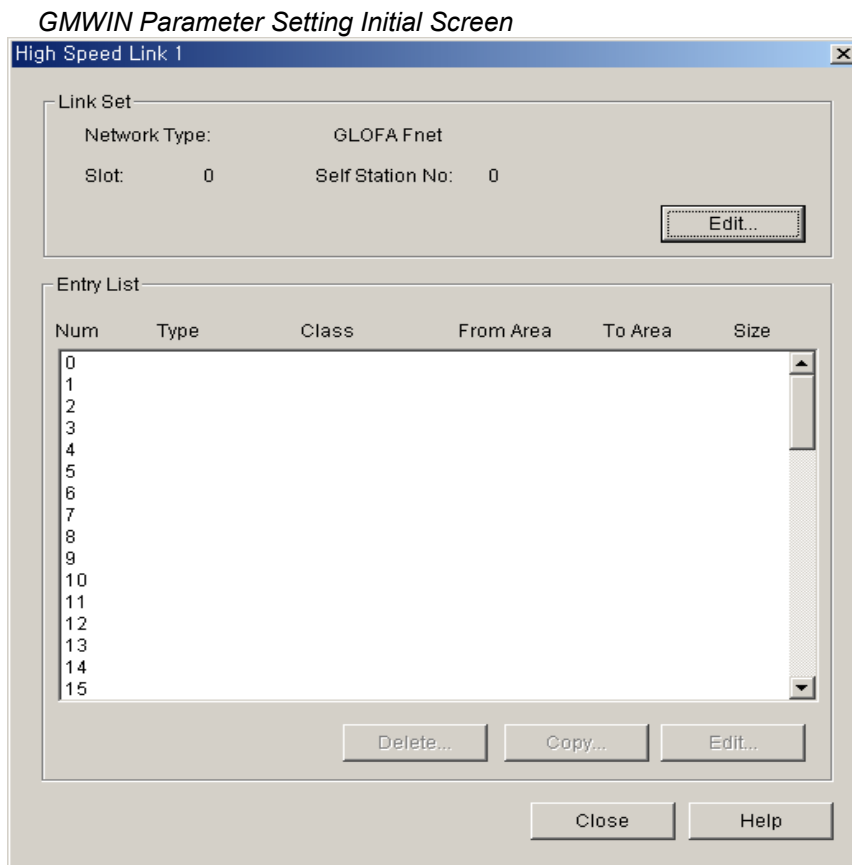

Parameter setting initial screen is composed of two items such as “Link set’ and “Entry list”, and the setting methods per each item and its function are as follows.

(a) Link Setting

Link setting is the item to set the basic articles of communication module to carry out *High-speed Link*.

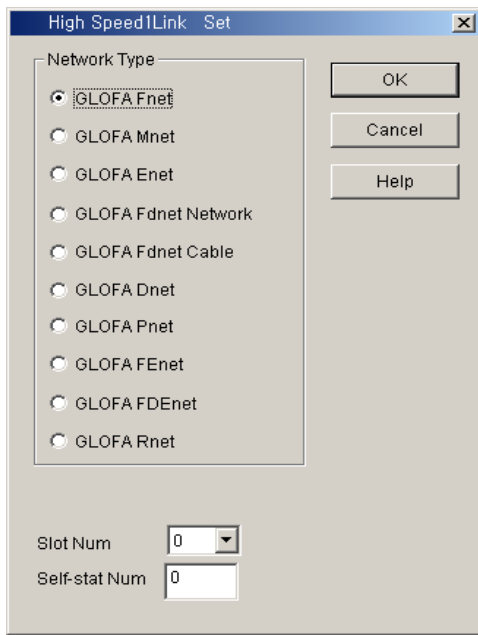

Network type: this is to set the type of communication module and select according to the installed communication module model type.

Slot number: set one of 0 ~7 for slot number that communication module is installed to (the right side of CPU module is “0” slot).

Self-station number: enter its own station no. that is set on the front side station no. switch of communication module. It is available to set 0~63 by decimal number. Self station number is unique number to distinguish communication module in the same network system, so don't use duplicated station number. (Station num. '0' in Profibus-DP is reserved (can not be used). Refer to Chap.5)

(b) Entry List Setting

Entry list is the area to register the actual sending/receiving data information. Set the registration no. from '0' of registration list area first and place the cursor on the desired position of number to set and double click or select 'Edit ...' button on the bottom of the screen to set the corresponding contents in the *High-speed Link* item modification screen.

High-speed Link item modification screen

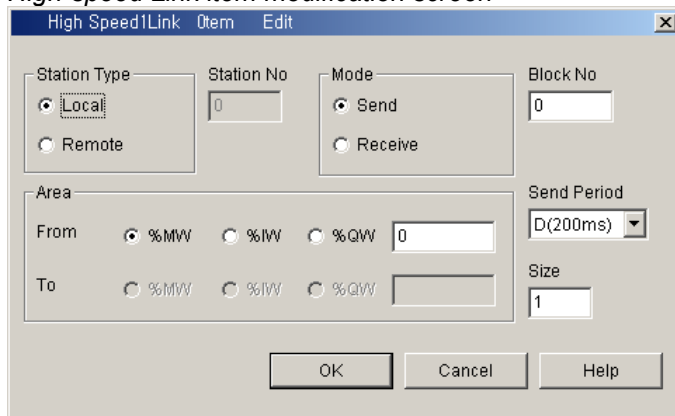

Example of sending parameter setting screen

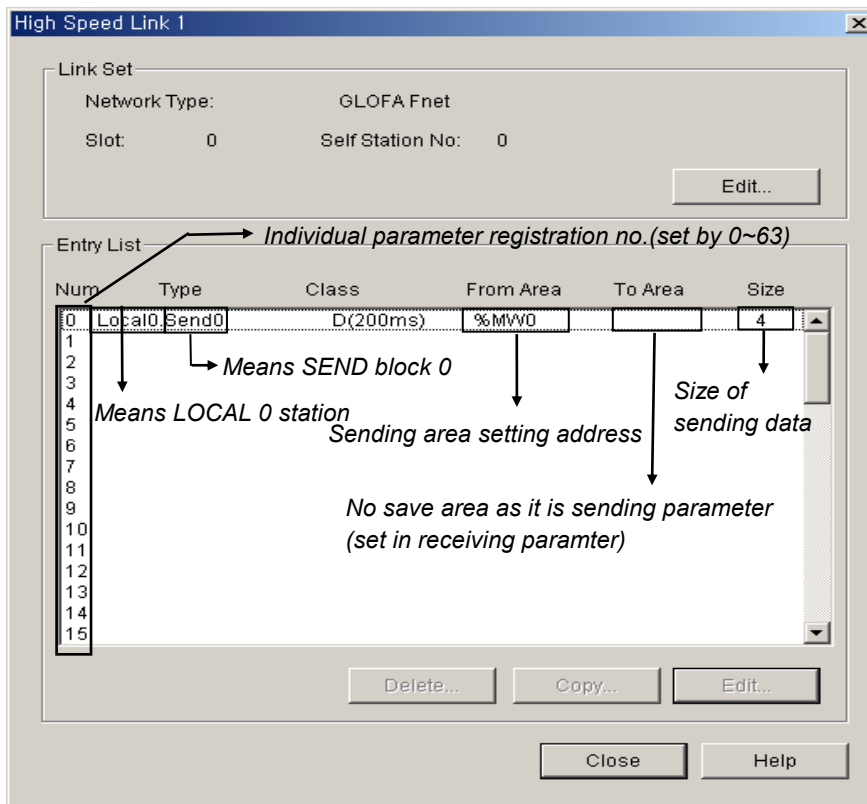

- **Entry List Num:** a serial no. indicating the order registered. Available to set 64 no.(from 0~63). Not related to the order of sending/receiving.
- **Station type:** this is the item to determine the type of other station to receive/send. Select remote type to communicate with Smart I/O.
- **Station no. :** in case that other station to communicate is local type, it is required to set the self station no. for sending and other station no. for receiving while in case of remote type, set other station no. all for sending/receiving. Thus, it is required to set the remote station no. when sending/receiving as Smart I/O series because it does not have parameter setting function in the remote station itself.
- **Mode:** this is the item to determine whether or not to send/receive data of the corresponding block. When receiving, select 'receive". The number of sending/receiving block is available to set max. 32 and if setting more than 32, the parameter error occurs and the normal communication does not work.
- **Block no. :** this is the parameter to send/receive lots of data of various area, from one station and distinguish the data of various block, form each other. Generally, the station no. and block no. set by sending station is transmitted together with sending data and if the receiving station wants to receive this data, it is required to receive it as the corresponding block no. sent by sending station. The block no. of sending/receiving for one station is available to set max. 32 and it is not allowed to set the same block no. for the same station no. For remote station, it is set differently regardless of sending/receiving.
- **Area:** after selecting data area to send/receive, enter the address direct and set the area.

Remote sending: read any data of the self station (designate one from %MW, %IW, %QW within the area to read) and designate which area of remote station is sent to (%QW is only available to designate in the storage area. Remote sending data is available to send in the remote output side.)

Remote receiving: read any area of other remote station not the own station (%IW is only available to designate in the storage area. It is available to read the remote input data) and designate position of the own station to save from %MW, %IW, %QW. As memory map is different according to CPU models,

please refer to memory map described on the corresponding manual.

The following shows the setting available area according to station type.

Setting Area according to Station type

Remarks		Sending			Receiving		
		%IW	%QW	%MW	%IW	%QW	%MW
Remote	Area to read	O	O	O	O	X	X
	Storage area	X	O	X	O	O	O

O: setting available X: setting not available

Remark

- 1) The address of Smart I/O series is allocated as %IW0.0.0 ~ %IW0.0.1 in case of input, and %QW0.0.0 ~ %QW0.0.1 in case of output.

- **Size:** data size to send/receive unit is 1 word (16 points).

- **Sending/Receiving period:** *High-speed Link* is the service to carry out the sending/receiving by the parameter set by the user at the point that PLC program ends. Thus, when PLC program scan time is short within several ms, communication module begins to transmit the data according to every program scan which result in increasing the communication amount and reducing the effectiveness of overall communication system. Thus, to prevent this, the user can set the sending/receiving period from min. 20ms to max. 10sec. If not setting, it shall be set as basic value of 200ms automatically. Sending/Receiving period means the sending period in case that the corresponding block is set as 'sending' and the data receiving check period of the corresponding block in case that it is set as 'receiving'. If PLC program scan time is longer than the setting sending period, it shall be sent at the point that PLC program scan ends and the sending period becomes to be equal to PLC program scan time.

Data Sending Delay Time (PLC program scan time > sending period)

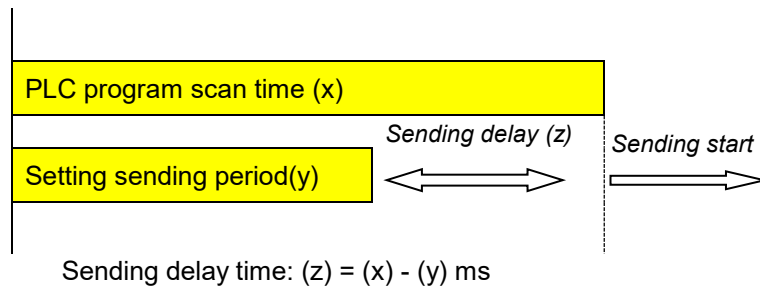

Data Sending Delay Time (PLC program scan time < sending period)

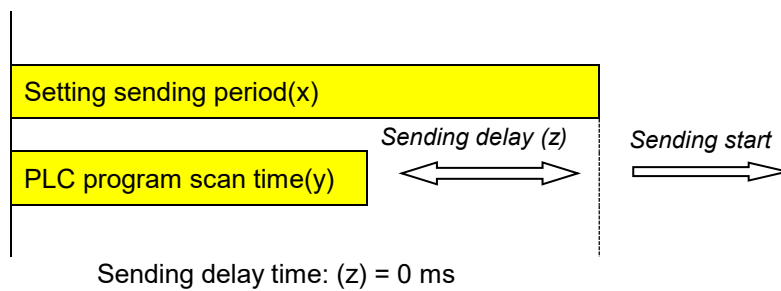

Remark

- 1) When setting the receiving period, the user can check if it is set as the value greater than the period of the corresponding block set by other station to receive normally.

(4) High-speed Link operation

When *High-speed Link* parameter setting is completed, execute 'make' from compile menu of GMWIN and then write parameter with PLC CPU. After that, if starting the *High-speed Link* service, *High-speed Link* service by parameter setting will begin. The start order of *High-speed Link* is as follows.

Parameter Write

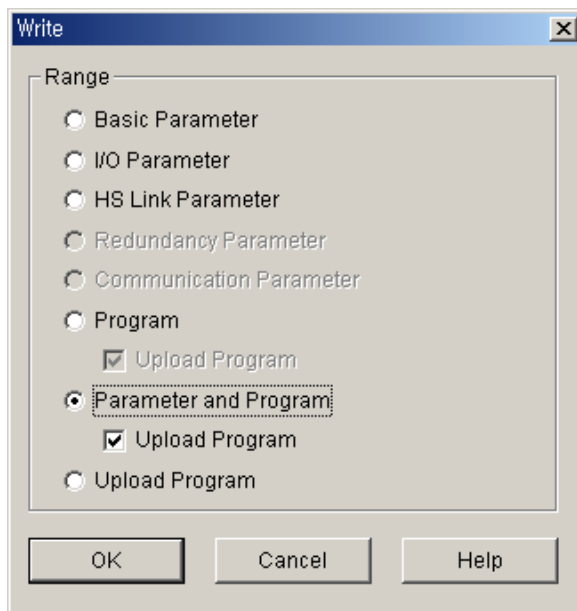

After saving *High-speed Link* parameter written by the user in GMWIN project file and connecting to PLC through 'online connect' of GMWIN basic menu, select 'write' and the window 'write' appears as above. If you select '*High-speed Link* parameter' or 'parameter and program' from the above menu and download the selected parameter, the corresponding contents shall be downloaded.

In this case, Link Enable which is *High-speed Link* start information shall be OFF. Therefore User has to click on the appropriate item of *High-speed Link* in link Enable setting.

(5) High-speed Link start

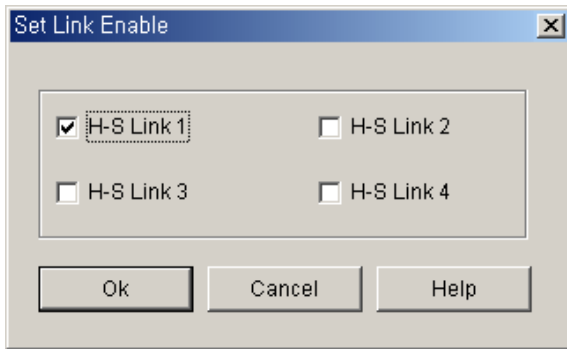

After 'parameter write', *High-speed Link* maintains all 'stop' but after the user sets Link Enable, *High-speed Link* runs.

'Set Link Enable' is available only for PLC stop mode. And if 'set *High-speed Link* Enable' starts, *High-speed Link* runs regardless of PLC action mode. Also, parameter and link enable information shall be preserved by having battery backup in PLC CPU even when power is off.

Relation of PLC mode and High-speed Link

Classification	Parameter download	Set Link enable	<i>High-speed Link</i> action	Remarks
PLC RUN	X	X	O	<i>High-speed Link</i> Only if allowed Act
PLC STOP	O	O	O	
PLC PAUSE	X	X	O	
PLC DEBUG	X	X	O	

4.2.5 KGLWIN Link Parameter Setting

In case of KGLWIN, its function is the same as that of GMWIN and its operating method and setting is also the same. Select 'Link' from KGLWIN project menu and program it.

(1) High-speed Link project setting

If selecting 'Link' from Project menu, *High-speed Link* parameter basic screen will appear.

KGLWIN Project Basic Screen

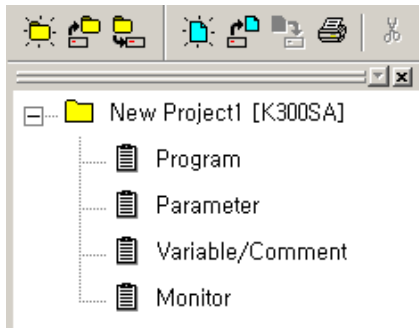

(2) Link parameter selection

(a) Setting method: select 'parameter'-'link' from project screen.

KGLWIN Parameter menu

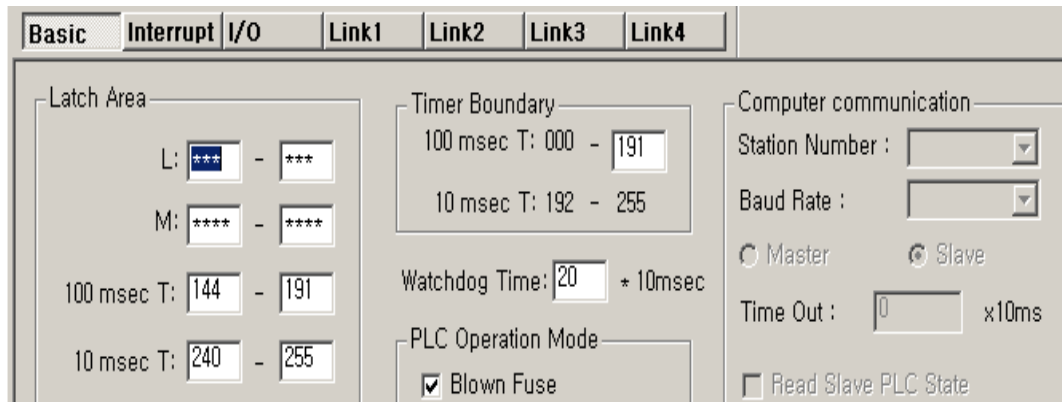

(b) Setting function: KGLWIN link 1~4 means max. Installation No. of communication module according to master PLC CPU types.

- 1) If using one communication module, select link 1.
- 2) Only one *High-speed Link* parameter is available to set for one communication module.

(3) Link initial setting

KGLWIN contains all general contents necessary for communication setting in link items, and the setting method is the same as that of GMWIN.

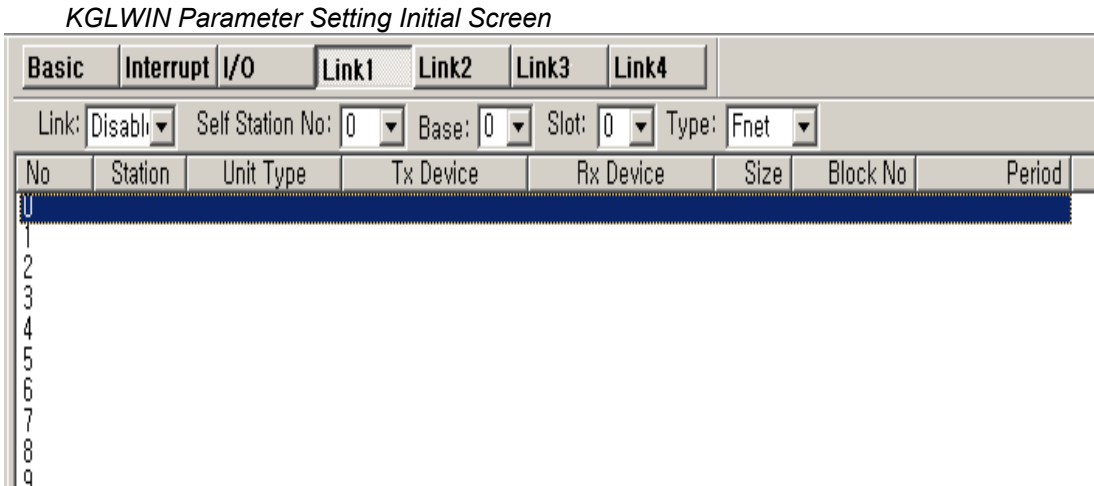

Parameter setting initial screen is composed of two items such as 'Link setting' and 'Entry list'. The setting method and function per each item is as follows.

(a) Link

Link is the Enable condition to carry out *High-speed Link* of the setting parameter.

- Permit: High-speed Link is ON*
- Prohibit: High-speed Link is OFF*

(b) Self Station no.

Enter its own station no. that is set on the station no. switch of communication module front side. It is available to set 0~63 by decimal number. Self station number is a unique number to distinguish communication module in the same network system, so don't use duplicated station number.

(c) Slot

Set the slot no. that the desired communication module to set is installed by selecting one from the range of '0'~'7'.

(d) Type

Designate master communication type to communicate with Smart I/O module.

- Rnet: Fieldbus communication module*
- Pnet: Profibus-DP communication module*
- Dnet: DeviceNet communication module*

(4) Link Setting Details

This is KGLWIN link item modification menu. If the user set the sending/receiving with the device to communicate actually, the parameter setting is completed.

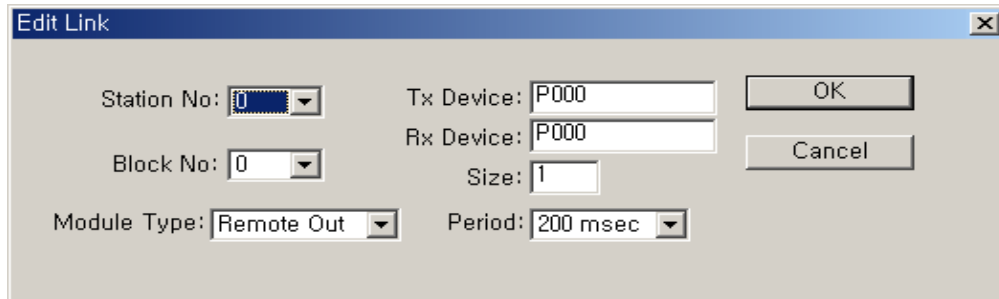

(a) Station no.

Sets the station No. of other station (remote station) to communicate with Smart I/O station.

(b) Block no.

This is the parameter to be set to send/receive lots of data of various area from master and distinguish the data of various block forms from each other. For remote station, it is set differently regardless of sending/receiving.

(c) Communication type

This designates the communication method that master will carry out. Also, distinguishes the communication type for local station and remote station.

Local sending: sets data sending between local stations

Local receiving: sets data receiving between local stations

Remote sending: sets data sending to remote station (Smart I/O)

Remote receiving: sets data receiving from remote station (Smart I/O)

(d) Tx device/Rx device

This means the area of sending/receiving and for setting, please refer to the table as below.

Classification	Mode	Setting available area	Remarks
Remote output	Tx	P, M, L, K, F, D, T, C all area	Sending area of its own station
	Rx	P area	Receiving area of remote station
Remote input	Tx	P area	Sending area of remote station
	Rx	P, M, L, K, D, T, C area	Receiving area of its own station

(e) Size

Sets the size of sending/receiving data and the basic unit is **Word**.

(But, in case of **DeviceNet**, basic unit is **Byte**.)

(f) Communication period

High-speed Link is the service to carry out the sending/receiving by the parameter set by the user at the point that PLC program ends. Thus, when PLC program scan time is short within several ms, communication module begins to transmit the data according to every program scan which results in

increasing the communication amount and reducing the effectiveness of overall communication system. Thus, to prevent this, the user can set the sending/receiving period from min. 20ms to max. 10sec.

(5) High-speed Link operation

High-speed Link in KGLWIN is performed automatically with the program download according to communication setting.

4.2.6 XG5000's Link Parameter Setting

High-speed Link is a parameter setting method to set device region and data size easily to communicate between CPU module and Communication module (Master module and Slave module) by using XG5000.

(1) Dnet/Pnet High-speed Link Contents

Contents		High-speed Link			
Communication module setting	Communication module setting	Module Type	Selecting Dnet	Selecting Pnet	
		Base No.	Max: 0 ~ 7, Setting range differ according to CPU module.		
		Slot No.	Max: 0 ~ 11, Setting range differ according to base Type.		
	Communication period setting (Period Type)	Select among 20ms, 50ms, 100ms, 200ms, 500ms, 1s, 5s, 10s -default is 20ms.			
	Output data setting when emergency	CPU Error	Latch	Maintain previous output status.	
			Clear	Clear all output.	
		CPU Stop	Latch	Maintain previous output status.	
			Clear	Clear all output.	
	Mode *1	Sending: Deliver data from Master module to Slave module. Receiving: Deliver data from Slave module to Master module.			
	Station No. *1	Slave Station No. *1 (Range: 0 ~ 63)			
	Communication type *1	Indicate communication type between Master and Slave. (Poll, Bit-Strobe, COS, Cyclic)			
	Reading area (Master module → Slave module)	Address	Sending device's first device Available device: P, M, K, F, T, C, U, Z, L, N, D, R, ZR		
		Size*1 (Byte)	Indicate I/O point into Byte. - Consider less than 8 bit I/O module as 1 Byte		
	Storage area (Slave module → Master module)	Address	Receiving device's first device Available device: P, M, K, F, T, C, U, Z, L, N, D, R, ZR		
		Size*1 (Byte)	Indicate Slave module's I/O point into Byte. - Consider less than 8 bit I/O module as 1 Byte		
PLC connection	CPU module's RS-232C or USB port				
Control condition	Control is available regardless of location (RUN, STOP) of RUN module switch of CPU module.				
Max. communication point	Sending 28,672 point, Receiving 28,672 point each 3584 byte				
Max. Block No.	63 (setting range: 0~62)				
Max. point per block	255 Byte (2,040 point) (Setting range 1 ~ 255)				
High-speed link setting No.	Max. 12				

Notice

- *1: 1) The above category is not set in XG5000.
 2) This data is uploaded value from XG5000 which is set in SyCon.
 3) Set according to the following sequence.
 First: Set parameter by SyCon → download
 Second: XG5000 → I/O Information Reading → SyCon Upload → High-speed Link parameter setting → parameter download → High-speed Link approval
 If you follow the wrong sequence, it may cause change of setting value.
- ▶ When you change High-speed Link contents, you should download parameter again.
 - ▶ It is available to set and use only one High-speed Link per one communication module.
 - ▶ Written parameter (basic, High-speed Link, P2P) is stored in CPU module.
 When changing CPU module, download backup parameter set in XG5000 and write it to new CPU module.

(2) How to use XG5000

How to use XG5000 for Dnet I/F Module is as follows.

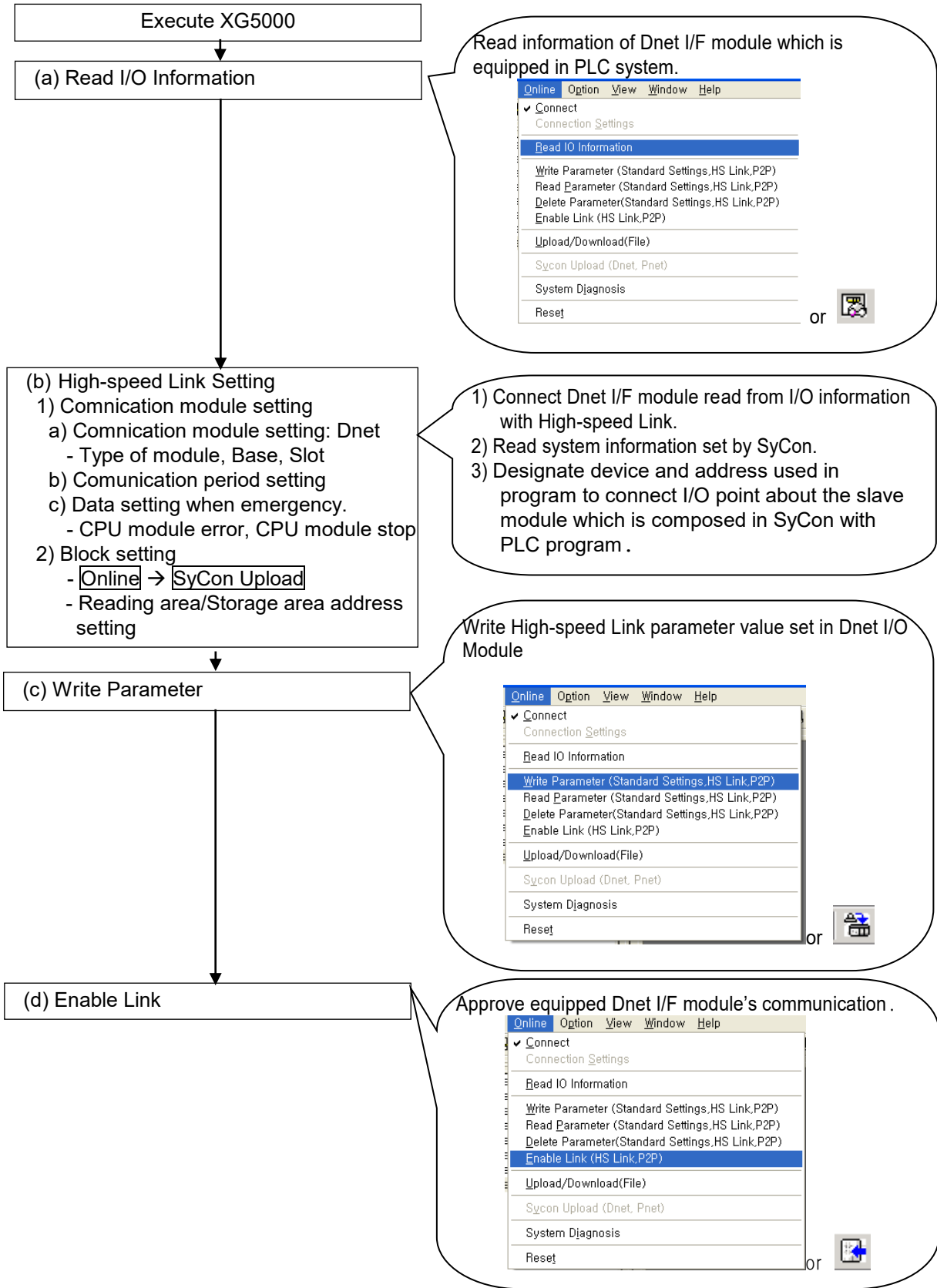

4.2.7 High-speed Link communication status flag information (GM/MK)

(1) High-speed Link information function

To confirm the reliability of data read from other station through *High-speed Link*, it provides the user with the method to confirm the *High-speed Link* service as *High-speed Link* flag information. It has individual information such as HS_STATE, TRX_STATE, DEVICE_MODE, ERROR that informs the communication status per 64 registration items in the flag of run-link, link-trouble and parameter that informs the overall status of *High-speed Link*. The user can utilize the above information by combining with *High-speed Link* sending/receiving data as keyword type when writing the program in case of emergency or maintenance.

High-speed Link information

Classification	Run-link	Link-trouble LINK_ TROUBLE	Sending/ receiving status TRX_MODE	Action mode DEV_MODE	Error DEV_ERROR	High-speed Link status HS_STATE
Information type	Overall information	Overall information	Individual information	Individual information	Individual information	Individual information
Keyword name (□=HS link no. 1,2,3,4)	_HS□RLINK	_HS□LTRBL	_HS□TRX[n] (n=individual parameter no.0~63)	_HS□MOD[n] (n=individual parameter no. 0~63)	_HS□ERR[n] (n=individual parameter no. 0~63)	_HS□STATE[n] (n=individual parameter no. 0~63)
Data type	BIT	BIT	BIT-ARRAY	BIT-ARRAY	BIT-ARRAY	BIT-ARRAY
Monitoring	Available	Available	Available	Available	Available	Available
Program	Available	Available	Available	Available	Available	Available

(1) Run-Link (_HS□RLINK)

This is the overall inform set by the user. Once 'ON', it maintains 'ON' until link enable is 'OFF' and if the following condition that shows whether or not *High-speed Link* is running normally by the parameter condition is given, it shall be 'ON'.

- ① when link enable is 'ON'.
- ② when parameter registration list setting is set normally all.
- ③ when sending/receiving all data that corresponds with parameter registration list within the setting period.
- ④ when all other station status set in the parameter is 'RUN' and at the same time there is no error.

RUN-LINK ON condition

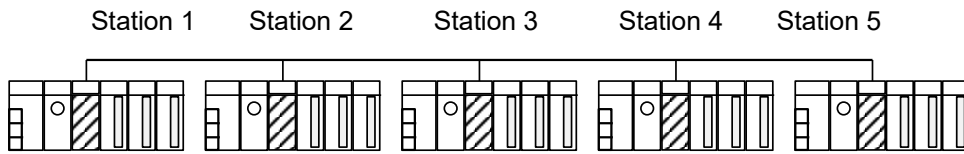

(a) High-speed Link system configuration

Station 1	Station 2	Station 3	Station 4	Station 5
Sending: 2words	Sending: 2words	Sending: 2words	Sending: 2words	Sending: 2words
Receiving: 2words (station 2)	Receiving: 2words (station 1)	Receiving: 2words (station 1)		
Receiving: 2words (station 3)	Receiving: 2words (station 4)	Receiving: 2words (station 5)		

(b) Examples of High-speed Link parameter setting for each station

The figure shows High-speed Link system configuration to explain RUN-LINK ON condition. In case that 5 communication modules are connected by network as shown (a) of the figure and carry out High-speed Link as the content of parameter of figure (b), RUN-LINK ON condition of Station 1 is as follows.

- ① when in the self station (station 1), Enable Link is 'ON',
- ② when the self station (station 1) is RUN status,
- ③ when the self station (station 1) is not the error status,
- ④ when the sending parameter data set in the self station (station 1) is sent properly for the sending period,
- ⑤ when the data receiving from station 2,3 is received properly for the receiving period,
- ⑥ when the action mode of other station (station 2, 3) to send the data to the self station (station 1) is RUN mode and not the error status and it is communicated properly for the sending/receiving period,
- ⑦ when in the other station (station 2,3) of the self station (station 1), the action mode of other other station (station 4,5) set in the parameter is RUN mode and not the error status and it is communicated properly for the sending/receiving mode.

If the above 7 items are satisfied, RUN-LINK of station 1 shall be ON. If using RUN-LINK contact associated with program in the system where PLC of various stations performs interlocking through High-speed Link, it is available to carry out the mutual monitoring of sending/receiving data and the reliable communication. But, once RUN-LINK contact is 'ON', it maintains 'ON' status until Enable Link becomes 'OFF'. Thus when monitoring the abnormal status such as communication error, it is required to use link trouble information contact together as follows.

(2) Link-Trouble (_HS□LTRBL)

When RUN-LINK violates the condition of RUN-LINK ON in the status that RUN-LINK is ON, LINK-TROUBLE shall be 'ON' and if recovered, it shall be 'OFF'.

(3) Sending/Receiving status ($_TRX\Box STATE[0..63]$)

When the parameter action that is set in the individual parameter registration no.(0~63) respectively and is carried out properly in accordance with sending/receiving period, the corresponding bit shall be 'ON' and if not carried out, it shall be 'OFF'.

(4) Action mode ($_HS\Box MODE[0..63]$)

It describes the parameter action mode information that is set in the individual parameter registration no.(0~63). If the station set in the registration item is RUN mode, the corresponding bit shall be 'ON' and in case of STOP/PAUSE/DEBUG mode, it shall be 'OFF'.

(5) Error ($_HS\Box ERR[0..63]$)

It describes the parameter error information that is set in the individual parameter registration no.(0~63). The error indicates generally the status that the PLC does not carry out the user program normally. If it is 'OFF', this means that the PLC of other station works normally, and if 'ON', this means that the other station is in the abnormal status.

(6) *High-speed Link* status ($_HS\Box STATE[0..63]$)

It describes the general information for registration list by collecting all individual information per item. That is, if the sending/receiving status of the corresponding list is normal and the action mode is RUN and there is no error, it shall be 'ON' and if violating the above condition, it shall be 'OFF'.

Remark

Among the keywords used in (1)~(6) items

\Box : describes *High-speed Link* no.(1,2,3,4) used when setting the parameter.

(if the installed communication module is one, *High-speed Link* 1 shall be used.)

[0..63] : describes individual parameter registration no.

(check the communication status of each parameter that is in the registration no.0~63.)

Remark

1) In case of Profibus-DP module, it has other *High-speed Link* flag. For further information, please refer to '5.3.12 *High-speed Link* information in GMWIN'.

4.2.8 High-speed Link communication status flag information (XGT)

Communication Flag List corresponding to High-speed Link Number High-speed Link No.1~12.

No.	Keyword	Type	Contents	Contents Explanation
L000000	_HS1_RLINK	Bit	All stations of High-speed Link No.1 are normal.	It indicates normal status of all stations which operate according to parameter set in the High-speed Link. If the following condition is met, It would be turned On. 1. All stations set in parameter are RUN mode and there is no Error. 2. All data blocks set in parameter operate properly. 3. When parameter of each station in parameter communicates normally, after Run_Link is On, Run_Link maintains On continuously unless quitted by disable.
L000001	_HS1_LTRBL	Bit	Indicates abnormal After _HS1RLINK ON	When _HSmRLINK Flag is On, if station set in parameter and communication status is same as the followings, this flag is turned On. 1. Station set in parameter is not RUN mode. 2. Station set in parameter has Error. 3. Communication status of data block set in parameter is not proper. If above condition is met, Link_Troble set On. If condition is normal, Link_Troble set Off.
L000020 ~ L00009F	_HS1_STATE[k] (k=000~127)	Bit Array	Indicates High-speed Parameter No.1 Kth Block's total status	It indicates total status about each data block set in parameter. HS1STATE[k]=HS1MOD[k]&_HS1TRX[k]&(~_HSmERR[k])
L000100 ~ L00017F	_HS1_MOD[k] (k=000~127)	Bit Array	Run Mode of High-speed Parameter No.1 Kth Block	It indicates operation mode of station set in Kth block of parameter.
L000180 ~ L00025F	_HS1_TRX[k] (k=000~127)	Bit Array	Indicates normal Communication status with High-speed Parameter No.1 Kth Block	It indicates whether communication status of parameter's Kth data block operates normally or not according to setting.
L000260 ~ L00033F	_HS1_ERR[k] (k=000~127)	Bit Array	Error Mode of High-speed Parameter No.1 Kth Block	It indicates whether communication status of parameter's Kth data block has error or not.
L000340 ~ L00041F	_HS1_SETBLOC K[k]	Bit Array	Indicates setting of High-speed Parameter No.1 Kth Block	It indicates whether Kth data block of parameter is set or not.

* In case of Dnet and Pnet, Kth block indicates slave's station number.

Notice

High-speed Link Number	L Region Address Number	Reference
2	L000500~L00099F	When [Table 1]'s High-speed Link is 1, other Flag address number is as follows according to simple calculation. *Calculation: L region address number = L000000 + 500 X (High-speed Link Number-1) In the case of using the High-speed Link Flag for the program and monitoring, use Flag Map registered in the XG5000.
3	L001000~L00149F	
4	L001500~L00199F	
5	L002000~L00249F	
6	L002500~L00299F	
7	L003000~L00349F	
8	L003500~L00399F	
9	L004000~L00449F	
10	L004500~L00499F	
11	L005000~L00549F	

K indicates information about 128 Blocks from Block No.000 to 127 through 8 word (Each word consist of 16 block.). For example, mode information (_HS1MOD) has information about block 0 ~15 in the L00010. (16~31, 32~47, 48~63, 64~79, 80~95, 96~111, 112~127 in the L00011, L00012, L00013, L00014, L00015, L00016, L00017)

4.2.9 High-speed Link Speed Calculation

(1) Overview

High-speed Link data transmission speed can be determined by various factors.

Data transmission from one communication station to another communication station shall be performed through the following path.

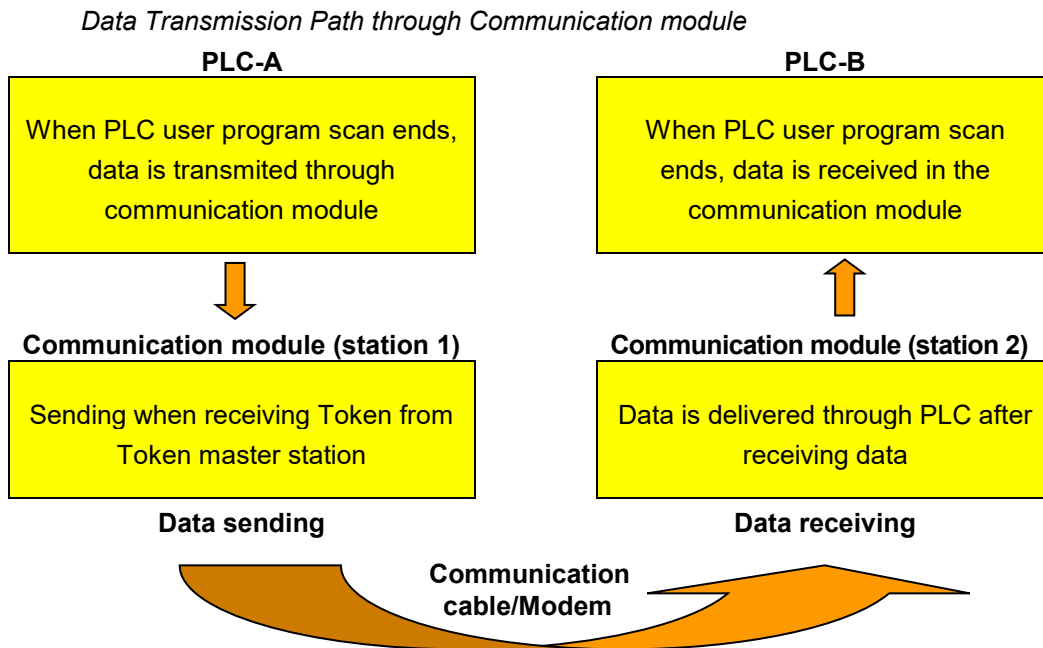

As shown on the above figure, there are 3 kinds of path to send data to other station through communication module and the sum of time to take for each path determines the sending time.

The table below describes the major path of data transmission and the factor that influences the transmission time per path.

Data Transmission Path and Time Factor

Path	Time factor
PLC CPU(A) --> communication module (station 1)	PLC-A program scan time
Communication module (station 1) --> Communication module (station 2)	Communication scan time + Communication O/S scan time
Communication module (station 2) --> PLC CPU(B)	PLC-B program scan time

As data delivery between PLC CPU and communication module is executed at the point when the user program of PLC ends, program scan time shall be the major factor of data transmission. Program scan time monitor can know the current program scan time

from program tool. And as data sending/receiving is carried out after obtaining the Token from communication module which allocates tokens so that communication module sends its own data, this time also is included in the communication delay time.

The following figure shows PLC program scan time and the sending point according to communication scan time.

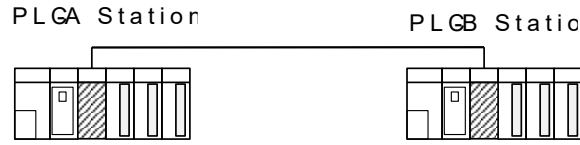

Relation of PLC scan time and Communication scan time

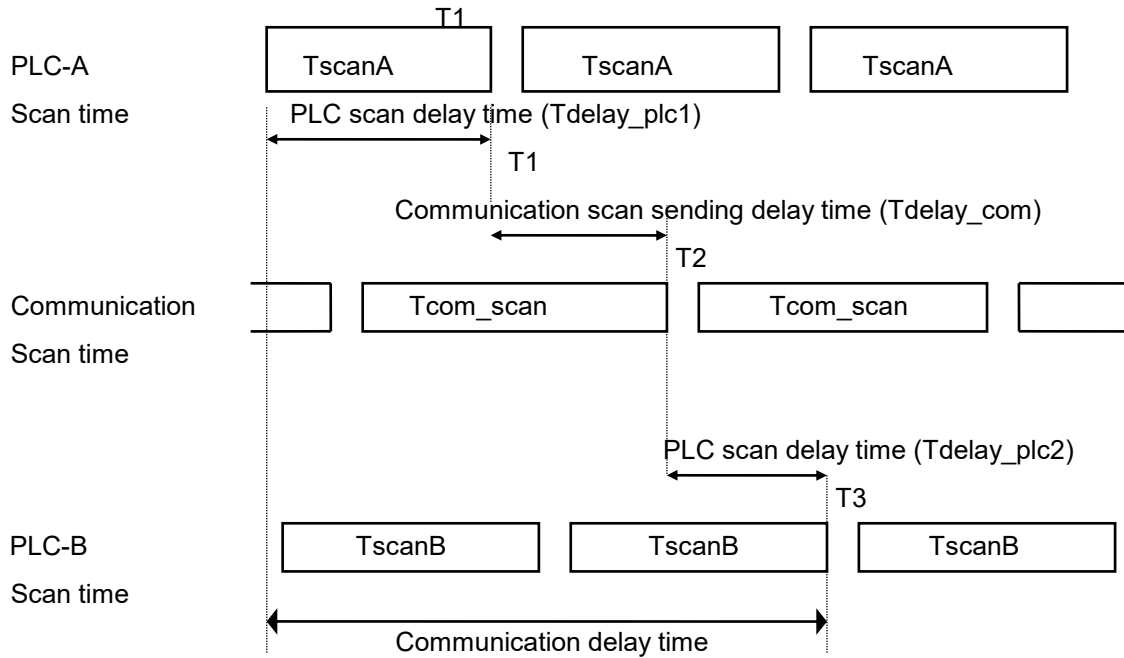

From the above figure, total communication delay time is $T1+T2+T3$.

As above, communication delay time shall be determined by various variables such as total no. of communication station, program size and O/S scan time of communication module. As these variables are difficult to calculate its value, we recommend the example of simple *High-speed Link* communication speed as follows.

(2) High-speed Link speed calculation method

High-speed Link speed shall be calculated with maximum time to take to send one block data from PLC-A to PLC-B by using the above figure as an example. As communication delay time is different according to the no. of overall communication station and program size, we divide into two cases such as complicated system that the sending data no. more than 10 communication station exceeds total 512 bytes and the simple system less than 512 bytes. It calculates *High-speed Link* speed as follows.

(a) Simple system

In the system that total communication station is below 10 stations and total sending data size is less than 512 bytes, you can calculate *High-speed Link* speed by using the following formula.

$$St = P_scanA + C_scan + P_scanB \text{ ----- [formula 4-1]}$$

St = *High-speed Link* max. Transmission time

P_scanA = PLC A max. Program scan time

C_scan = max. Communication module scan time

P_scanB = PLC B max. Program scan time

Each item shall be determined as follows.

$$\textcircled{1} C_scan = THT \times Sn \text{ ----- [formula 4-2]}$$

THT = Token Hold Time: Token use time per one station

Sn = Total Station Number: Total communication station number

$$\textcircled{2} \text{Token Hold Time (THT)} = \frac{Fnet}{Sn} \text{ ----- [formula 4-2]}$$

(b) Complicated system.

In the system that total communication station is more than 10 station and total sending data size is more than 512 bytes, you can calculate *High-speed Link* speed by using the following formula.

$$St = Et \times To \times Ntx + Mf \text{ ----- [formula 4-3]}$$

Et = Effective Tx Ratio (Effective transmission Ratio)

To = Octet time (1 byte sending time)

Ntx = Total Tx number

Mf = Margin Factor

Each item shall be determined as follows.

- ① $E_t = S_n \times N_f$ ----- [formula 4-4]
 S_n = Total communication station number
 N_f = network factor and constant number value according to the communication system characteristic. In Fnet system, it is 1.5.
- ② T_o = Octet Time. The time to take to transmit one byte data to the serial data.
 - Fnet : 8 μ S
- ③ N_{tx} = total sending data number including Function Block/Instruction number and it is determined according to Fnet system as follows.
 - Fnet : sum of *High-speed Link* sending byte number + Variable F/B(Instruction) number $\times 256$
- ④ M_f = margin value for the factors not described like the above formula such as O/S scan time of communication module. Fnet is set as the following value.
 - Fnet : 16 ms

4.3 Function Block

4.3.1 Overview

Function Block is the function to write or read the specific data of the self station or the specific variable data in the specific area or specific variable area of other station when the regular event occurs, and it can be used diversely according to the purpose.

Program of Smart I/O series using the Function Block is limited all in Modbus Snet.
For further information, please refer to 'Chapter 8 Modbus Communication'.

4.3.2 Start of GMWIN Function Block

When programming by using Function Block, please refer to the following. Function Block carries out the variable setting by input section and output section. For the setting method, please refer to the corresponding Function Block.

It describes based on GLOFA GM7 Function Block.

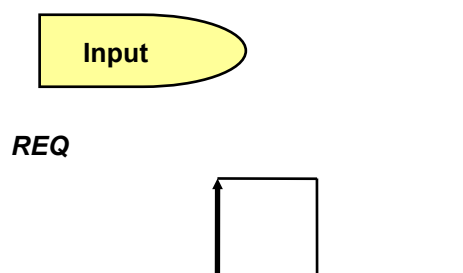

This is used as the start condition of mode bus Function Block and it starts at the rising edge from '0' to '1'. Once started, Function Block is not influenced until receiving the response from other station. After setting NDR or ERR bit, it shall be reset in next scan.

SLV_ADDR:

This sets the remote station number to communicate by performing this *Function Block*.

FUNC:

This enters modbus function code. For further information, please refer to 'Chapter 8 Modbus Communication'.

ADDRH:

This designates the starting address and middle/high address from the starting address to read in remote station.

ADDRL:

This designates the low address from the starting address to read in remote station.

NUMH:

This designates the high address of data size to read from starting address in remote station.

NUML:

This designates the low address of data size to read from starting address in remote station.

Output

NDR:

After *Function Block* starting, if data receiving is OK, it shall be 'ON'. When the corresponding scan ends, it shall be 'OFF'. If using this bit as other *Function Block* input condition, it is available for carrying out the reliable communication.

ERR:

After *Function Block* starting, if on error occurs, it shall be 'ON' and maintains 'ON' until the next *Function Block* starts again and then 'OFF'. If on error occurs, it is not available to receive data.

STATUS:

It describes the detailed code value for the error when on error occurs after starting *Function Block* and maintains the value until the next *Function Block* starts again and then 'OFF'.

Remark

Requirements of Function Block

- 1) Function Block requirements (REQ) start shall be executed after the previous execution is completed normally (after 'NDR' ON).

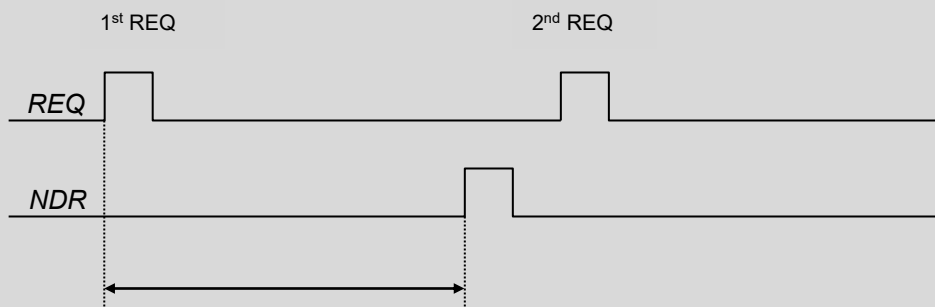

In communication = internal processing time + response wait time
(internal processing time : approx. 50 ~ 60ms)

4.4 Execution of KGLWIN Instruction

MASTER-K Instruction executes the programming by using KGLWIN Modbus Instruction.
Please refer to the Instruction execution method and available address area.
(Refer to Chapter 8.4.2 MASTER-K series (Modbus communication))

Chapter 5 Profibus-DP Communication

5.1 Overview

Profibus is an open type field bus that the manufacturer selects independently to apply and manufacture (Vendor-independence). Also, It is used widely for processing automation. DP among them is the most frequently used Communication profile and the network suitable for FA environment of Field Level and also is suitable for master-slave communication between master automation machine and distribution slave I/O machine. It is designed to install with low cost and is the most suitable item to replace the existing system such as 4~20mA or Hart system together with 24V parallel signal transmission to the production automation system.

Smart I/O module communication supports Profibus-DP through GM3/4/6 master module. (G3L-PUEA/ G3L-PUEB/G4L-PUEA/ G4L-PUEB/G6L-PUEA/ G6L-PUEB/XGL-PMEA/B/C)
 For further information for Profibus-DP, please refer to 'Profibus Association's homepage'. (<http://profibus.com>)

5.2 Communication Specification

Classification	G3/4/6L-PUEA	G3/4/6L-PUEB	XGL-PMEA/B/C
Module type	Master		
Network type	Profibus-DP		
Standard	EN 50170 / DIN 19245		
Media access	Logical Token Ring		
Communication method	RS-485 (Electric)		
Topology	Bus		
Modulation method	NRZ		
Communication cable	Shielded Twisted Pair		
Communication distance	1,200 m (9.6k ~187kbps)		
	400 m (500kbps)		
	200 m (1.5 Mbps)		
	100 m (3M ~ 12Mbps)		
Max. Node/network	126 Stations		
Max. Node/segment	32 Stations		
Max. I/O data	1 Kbyte	7 Kbytes	6 Kbytes
Communication parameter setting	Parameter setting by using GMWIN High-speed Link parameter and SyCon or nConfigurator		
Configuration tool	nConfigurator(XGL-PMEB/C), SyCon		
Configuration port	RS-232C configuration port supported (Except XGL-PMEB)		

5.3 Basic Performance

5.3.1 Overview

Profibus-DP Master module is available to set as the following function.

- (1) Supports only High-speed Link communication.
- (2) Uses parameter setting in GMWIN/KGLWIN/XG5000 and Configuration Tool (LS ELECTRIC provided tool: SyCon, nConfigurator).
- (3) Sets only sending/receiving area from GMWIN/KGLWIN/XG5000 high-speed link parameter setting.
- (4) Sending/receiving data shall be saved continuously from the setting area and sent. (this is similar to the continued MAP of MASTER-K.)
- (5) Uses SyCon to set sending/receiving number and slave area per slave station and uses Configuration Port to download as master module.
- (6) Sending/receiving number is available up to 512bytes/3,584bytes respectively according to the type of Daughter board.
- (7) Sending/receiving number per slave station is set as byte unit. (set in SyCon)
Communication begins through GMWIN/KGLWIN/XG5000 High-speed Link enable set.

5.3.2 Operation by High-speed Link

- (1) If Master module is the product of LS ELECTRIC (G3/4/6L-PUEA/PUEB, XGL-PMEA), it configures Profibus Network using SyCon.
- (2) It downloads Profibus Network Configuration as master module.
- (3) It sets High-speed Link parameter of master in GMWIN and downloads it.
- (4) It performs High-speed Link enable set.
- (5) If using other maker's product as Master, configure Profibus Network using Configuration Tool of the corresponding product.

Note

- 1) If using XGL-PMEB/C, it is required to use nConfigurator for the network configuration. The manual of nConfigurator can be downloaded from <http://www.lselectric.co.kr>

5.3.3 SyCon

If using master module provided by LS ELECTRIC (G3/4/6L-PUEA/PUEB, XGL-PMEA), it is required to configure Profibus Network using SyCon and download the information to the corresponding master module. As Profibus Network Configuration Tool is different from each master module, if using LS ELECTRIC master module (G3/4/6L-PUEA/PUEB,XGL-PMEA), it is required to use only SyCon.

SyCon execution



If there is no project using before executing SyCon, the initial screen same as the above figure will appear and if you are preparing the project, the latest project will be open.

Initial screen

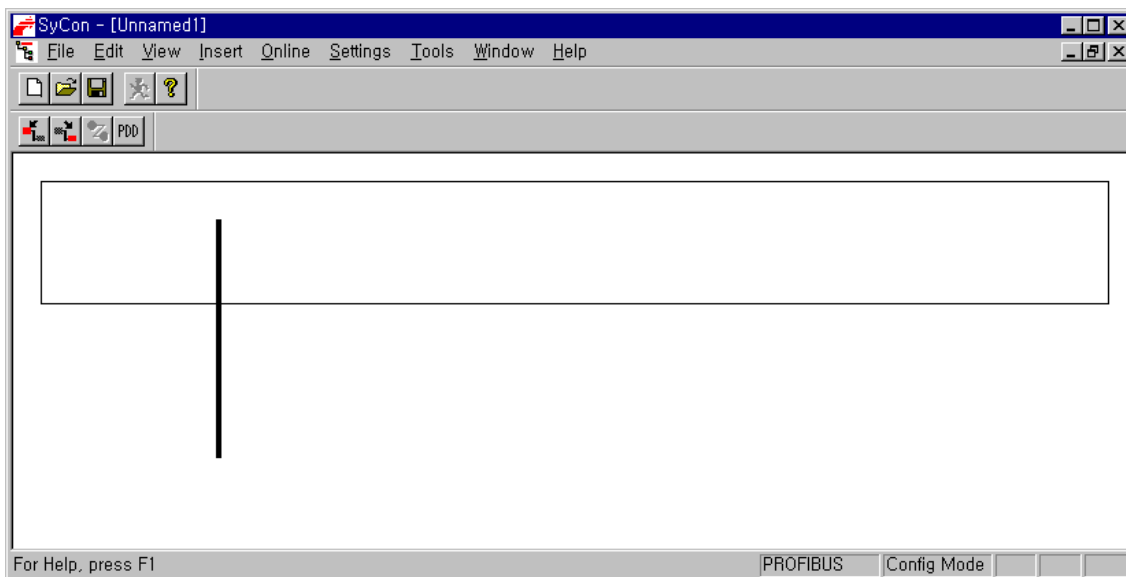

5.3.4 Insertion of Master Module

Select  from the left top tool bar and click the proper point of left top from the window below.

Tool bar

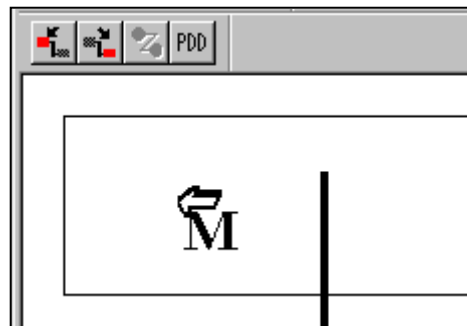

If Insert Master window is open as the above figure, select **COM-DPM/PKV20-DPM** if the using master module is **G3/4/6L-PU EA** and click Add button in the middle. If using master module is **G3/4/6L-PU EB**, select **COM-PB/PKV20-PB** and click Add button in the middle. If using master module is **XGL-PMEA**, select **COM-C-DPM** and click Add button in the middle part. Confirm Station address and if necessary, it is available to change Description. If pressing OK button, master module shall be inserted.

Master Insert

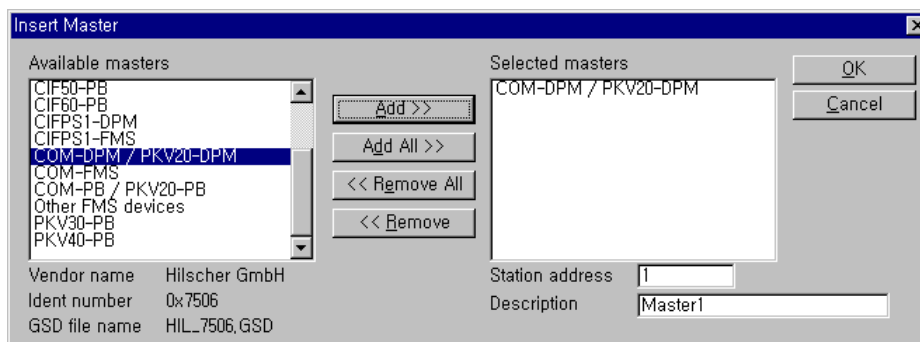

Inserted master module

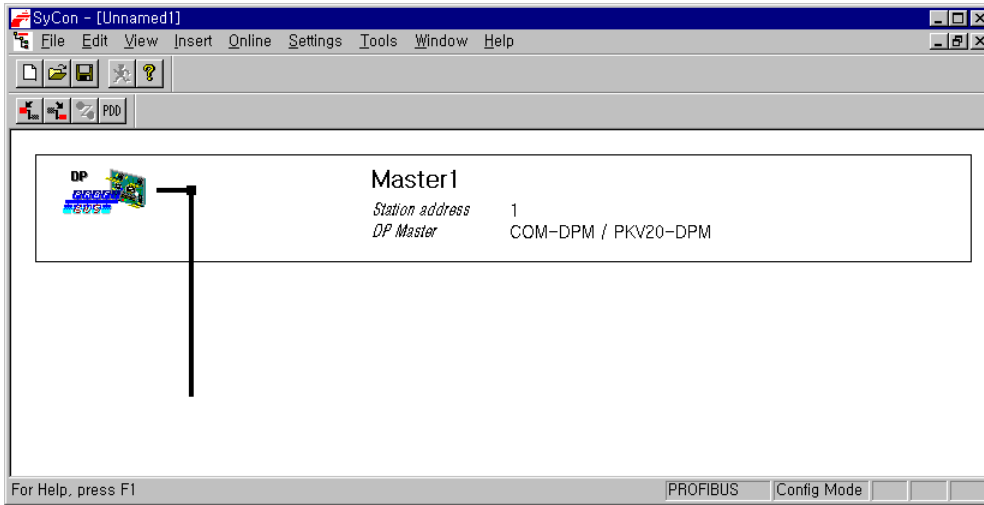

5.3.5 Master Module Setting

If you click the right side of mouse on the inserted master module and select “Master Settings...” from the appeared popup window, the following window will be open. Select “Controlled release of the communication by the application program” from “Parameter to user interface”, “Little Endian (LSB-MSB)” from “Storage format (word module)” and select “Buffered, host controlled” from “Handshake of the process data” in order.

Master Module Setting

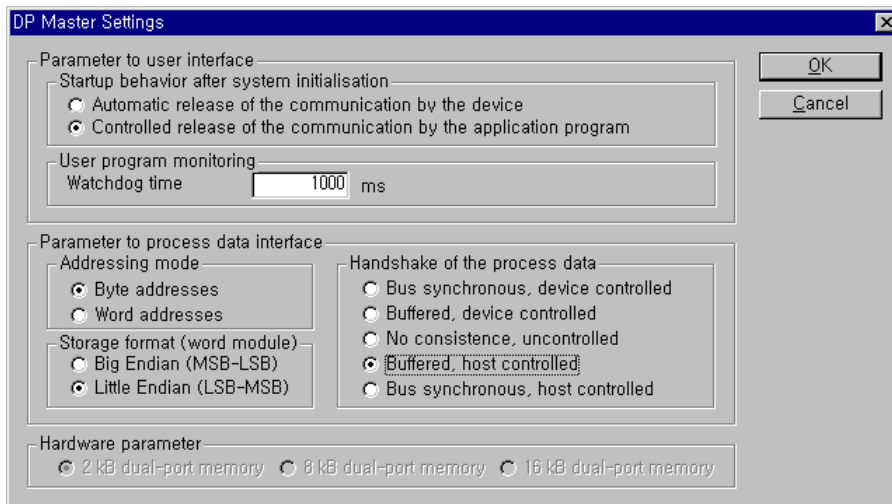

5.3.6 Insertion of Slave

Similar to master, select  from left top tool bar and click master bottom, and Insert Slave window will appear as below.

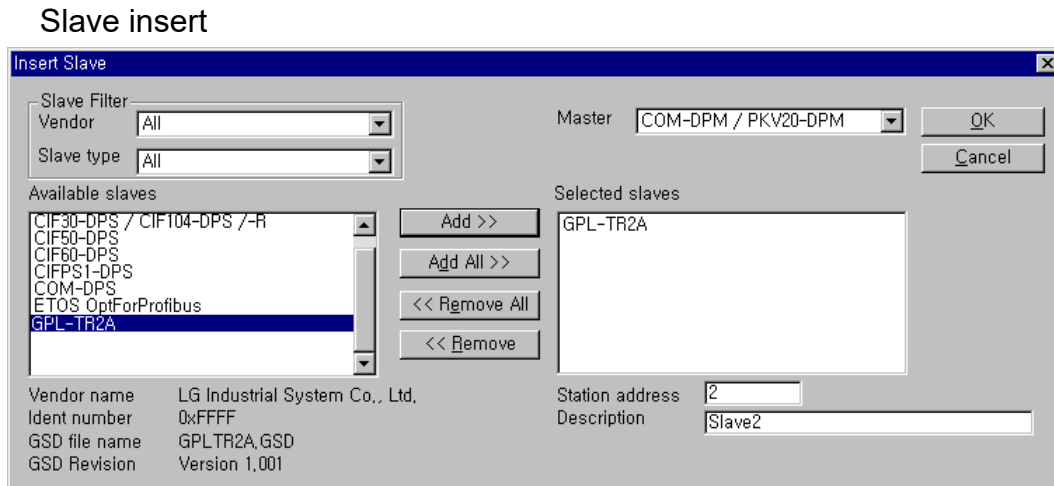

If using GPL-TR2A, select “GPL-TR2A” from the left side “Available slaves” and click “Add” button in the middle part. If there are several masters, select one from the right side “Master” and confirm “Station address” and “Description”, and then click “OK” button.

Remark

- 1) If there is no slave to use in the slave list (Available slaves) of insert slave window, copy “GSD file” which is the original self-information supplied by the module manufacturer, from the directory below. Then, try SyCon again and insert slave.

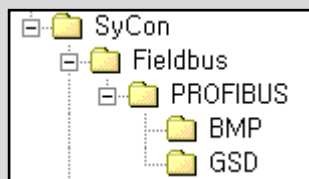

5.3.7 Slave Configuration

Click the inserted slave icon with the right button of mouse and select “Slave configuration” from the appeared popup window. (or double-click the left button of mouse on the slave icon.)

Slave Configuration

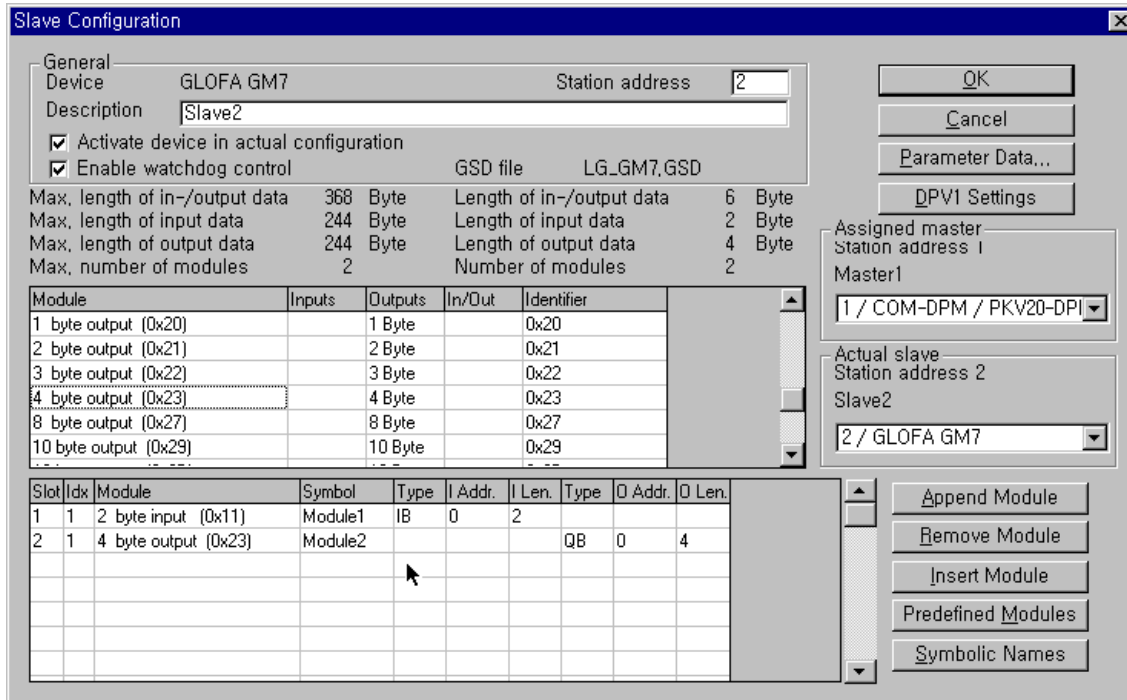

List box in the middle part shows all available modules. If you select the module having the necessary point and click “Append Module” button on the right bottom, it shall be inserted to the list box below. In this case, it is required to insert input module first and then insert output module in the bottom. And the numbers of available module are 2.

5.3.8 Bus Parameter Setting

Bus Parameter Setting

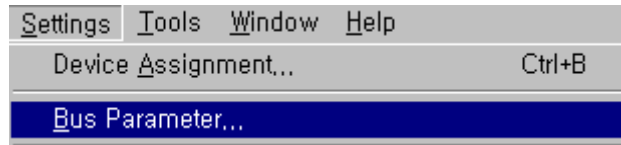

Bus parameter setting is the setting about Profibus-DP network. Select “Settings/Bus Parameter...” from the menu. Optimize field contains “Standard” and “user definition” setting. Speed setting (Baud rate) contains 9.6kbps ~ 12Mbps setting. Basically, Baud rate is set as 1.5Mbps and Optimize is set as ‘standard’.

Bus Parameter

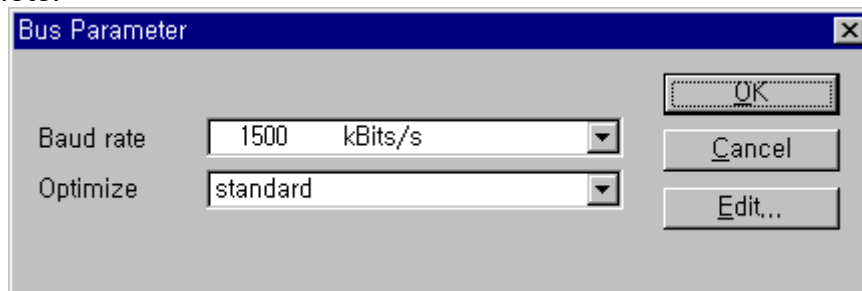

Remark

- 1) Communication speed is related to transmission distance.
- 2) When using 12Mbps, you should use the connector only for 12Mbps and exclusive cable.
- 3) When using 12Mbps, min. Distance between stations shall be set as more than 1m.
- 4) When using 12Mbps, if the communication is cut off (especially, the station far from master), search the proper end resistance value and set it random.

5.3.9 Device Allocation

It is required to download the prepared configuration to the master module. In this case, click the left button of mouse and select master module icon to set which device to use. Select "Setting/Device Assignment..." from the menu.

Device Allocation

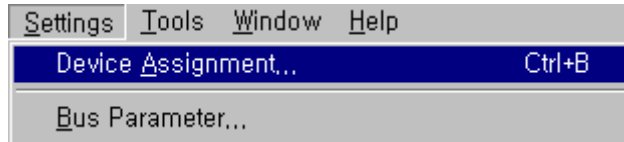

Driver Selection



If driver selection window is open, select "CIF Serial Driver".

Remark

- 1) Driver to be provided by G3/4/6-PUEA/B, XGL-PMEA type master module is only RS-232C port. Thus, "CIF TCP/IP Driver", "CIF Device Driver" is not available.

Driver Selection of CIF Serial Driver

Device Assignment CIF Serial Driver

Driver Description
Device Driver: CIF Serial Driver

Board Selection

	Name	Type	Version	Date	Error	
<input checked="" type="checkbox"/> COM 1	DPM	COM-DPM	V01.147	14.04.00	0	Connect COM 1
<input type="checkbox"/> COM 2					0	Connect COM 2
<input type="checkbox"/> COM 3					-20	Connect COM 3
<input type="checkbox"/> COM 4					-20	Connect COM 4

② If the corresponding module information is shown, check the "COM1" check box.

① "Connect COM1" press the button to confirm if the corresponding module information is indicated.

③ If everything ends normally without any error, press "OK" button.

This connects PC serial port and Configuration Port of Profibus-DP master module. Also it applies the power of master module. Press "connect COM1" or other button according to PC serial port and confirm if the corresponding module is selected. On the figure, "Version" and "Date" may have different value. If there is no error, check the check box of the left side and click "OK" button.

Remark

- 1) When pressing "Connect COM1" button, if the module information does not appear normally and the error occurs, check the connection of cable for configuration and the cable condition first.
- 2) If Cable is OK, it means that module must be poor. In this case, contact the customer service center.

5.3.10 Configuration Download

If you select “Online/Download” from the menu, ‘Download’ begins to run. In this case, all LED shall be OFF and only “READY” LED shall be blinking. After downloading, all LED show its function. If you carry out ‘Download’ in the status that the communication between the current master and slave is open, the warning window with the message **“if the download is done during the bus operation, the communication between the master and the slaves is stopped.”** will appear. After confirming if there is a problem by communication cutoff, click “Yes(Y)” button and ‘Download’ will run normally.

Configuration download

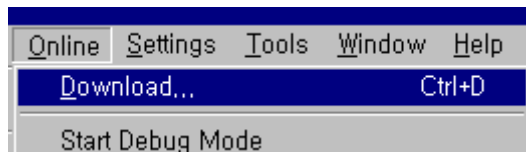

Download processing window

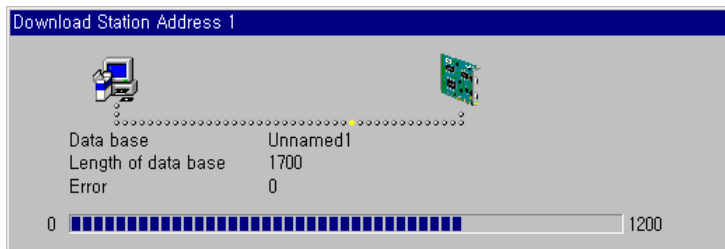

Warning message

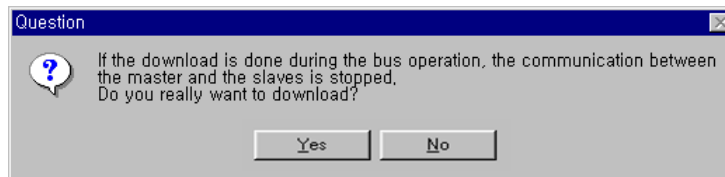

5.3.11 High-speed Link Parameter Setting in GMWIN

In the previous article, we explained the method to set Configuration and the method to download this to the master module. **High-speed Link parameter setting should be done after downloading Configuration** and High-speed Link parameter selects link parameter from GMWIN project screen and sets the corresponding items and the setting order. Its functions per item are as follows.

(1) High-speed Link parameter setting in GMWIN

Open High-speed Link parameter from Project basic screen and enter into the High-speed Link parameter setting menu.

High-speed Link parameter basic screen

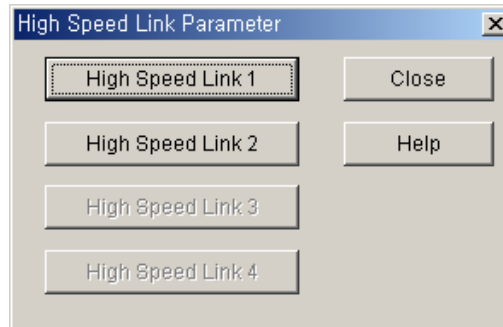

High-speed Link item of the above figure means the maximum Installation number of communication module according to PLC CPU type. High-speed Link button available for setting is active and in this case, High-speed Link no. is not related to the installed slot no. and the slot no. should be set in the individual parameter setting screen and only one High-speed Link parameter is available to set for one communication module.

Max. Installation number per GLOFA-GM CPU model

Classification	Available communication module	Max. installation number	Remarks
GM3-CPUA	G3L-PUEA, G3L-PUEB	4	If combined with other communication module using HS link, installation number shall be limited.
GM4-CPUA/B	G4L-PUEA, G4L-PUEB	2 (A type) / 4 (B type)	
GM6-CPUA/B/C	G6L-PUEA, G6L-PUEB	2	
XGK/I-CPU	XGL-PMEA	12	

(2) Link parameter setting

If you select the corresponding parameter from parameter setting basic screen, the High-speed Link parameter setting initial screen will appear as shown in the following figure.

Parameter setting initial screen

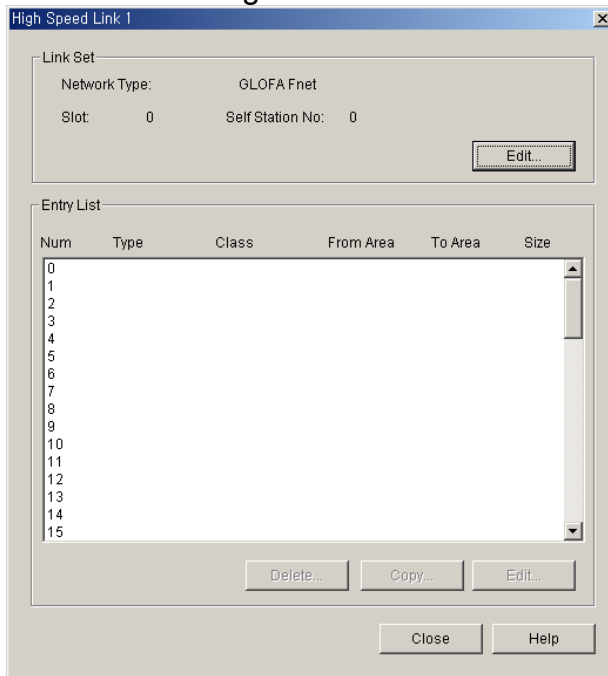

Parameter setting initial screen is composed of two items such as 'link set' and 'Entry list'. The setting method per each item and its function are as follows.

1) High-speed Link setting

High-speed Link setting is the item to set the basic items of the desired communication module to set. Select 'modify' button of link setting and set module type, slot no. the self station no. from High-speed Link setting screen respectively.

High-speed Link set screen

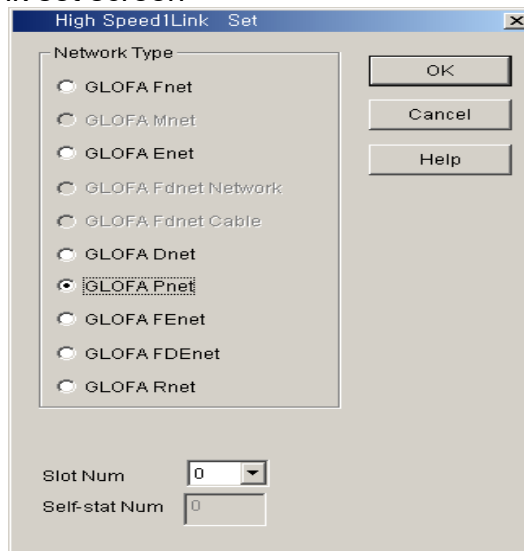

- Network Type: It sets the installed communication module type and GLOFA Pnet should be set.
- Slot Num: It sets the position that the communication module to set is installed. (0 ~ 7 slot).
 - Self-station Num: The master module shall be set in SyCon and the slave module shall be set by rotary switch. It is not available to change here.

2) Entry List setting

Registration list is the area to register the sending/receiving information of actual data after link setting, it is required to set in the registration no.'0' of Entry list area, and the major setting items are shown on the top of registration list menu. Select (or double-click) the corresponding list from High-speed Link setting screen and the user can set the corresponding item from High-speed Link item modification window as shown on the figure below.

High-speed Link item modification screen

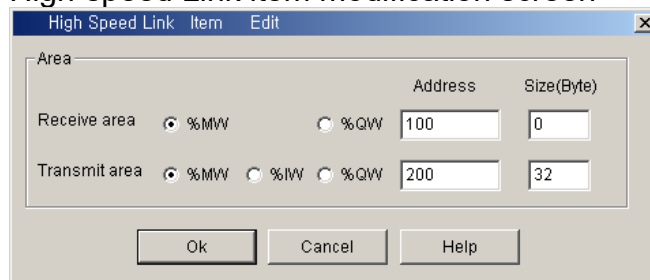

The following shows the screen after setting the sending/receiving parameter. Double-click the corresponding registration no. to modify the parameter.

Sending/Receiving parameter setting completion screen (example)

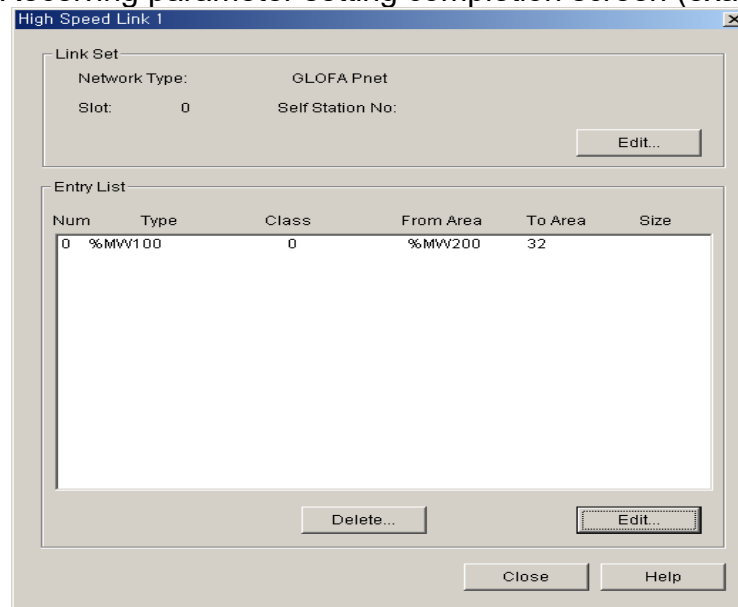

The function of each registration item is as follows.

- Area: When sending, set the area to read the data to send and set the storage area of the received data when receiving.
- Size: This means the data size to send/receive and the unit is 1 byte, and it is available to set total sending/receiving as 1Kbyte for G3/4/6L-PUEA and 7Kbytes for G3/4/6L-PUEB.

Remark

- 1) The size of sending/receiving area is total I/O contact number made in SyCon.
- 2) The order of programming is carried out as G4L-PUEA 1 and GPL-TR2A (16 points), GPL-TR4A (32 points), GPL-D22A (16 points) and when setting the sending area as %MW0, the receiving area as %MW100,
 - Sending area : %MW0
 - Receiving area : %MW100
 - Size of sending area : 6 bytes (total output contact number)
 - Size of receiving area : 2 bytes (total input contact number)And,
 - %MW0 data -> GPL-TR2A output
 - %MW1 ~ %MW2 data -> GPL-TR4A output
 - GPL-D22A input -> %MW100 saving
- 3) The setting order programmed in SyCon has the priority when sending/receiving the data than station no. and cable connection.

5.3.12 High-speed Link Information in GMWIN

(1) High-speed Link information function

High-speed Link service provides the user with the method to confirm High-speed Link service status to confirm the reliability of the data read from other station through High-speed Link as High-speed Link information because this is data exchange between more than 2 communication stations.

That is, the communication module provides the user with the high link information every regular time by collecting all data received until then about whether the High-speed Link action is done by the parameter set by the user or not. The High-speed Link information contains the overall information such as RUN-LINK (`_PHSxRLINK`), LINK-TROUBLE (`_PHSxLTRBL`) that provides the user with overall information of communication network and the individual information such as `_PHSxSTATE` that informs the communication status per slave station. The user can use the above information as keyword type when preparing the program and monitor the High-speed Link status by using the High-speed Link information monitor function. When operating several PLC using High-speed Link, it is required to confirm the reliability of the sending/receiving data using the High-speed Link information such as RUN-LINK, LINK-TROUBLE etc.

1) Run-Link (`_PHSxRLINK`)

This is the overall information that shows whether or not High-speed Link is running normally by the parameter set by the user. Once 'ON', it maintains 'ON' until link enable is 'OFF' and if the following condition is given, it shall be 'ON'.

- ① When 'Link Enable' is 'ON'.
- ② When parameter registration list setting is set normally all.
- ③ When sending/receiving all data that corresponds with parameter registration list within the setting period.
- ④ When all other station status set in the parameter is 'RUN' and at the same time there is no error.

High-speed Link system configuration

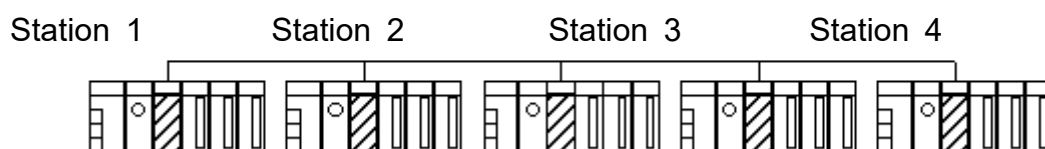

Example of High-speed Link parameter setting of each station

Station 1	Station 2	Station 3	Station 4	Station 5
sending:2 words receiving: 2words (station 2) receiving:2words (station 3)	sending:2words receiving:2words (station 1) receiving:2words (station 4)	sending:2words receiving:2words (station 1) receiving:2words (station 5)	sending:2words	sending:2words

The figure shows High-speed Link system configuration to explain RUN-LINK ON condition. In case that 5 communication modules are connected by network as shown on the above figure and carry out High-speed Link as the content of parameter, RUN-LINK ON condition of Station 1 is as follows.

- ① When in the self station (station 1), Link-Enable is 'ON',
- ② When the self station (station 1) is RUN status,
- ③ When the self station (station 1) is not the error status,
- ④ When the sending parameter data set in the self station (station 1) is sent properly,
- ⑤ When the data receiving from station 2, 3 is received properly,
- ⑥ When the action mode of other station (station 2, 3) to send the data to the self station (station 1) is RUN mode, not the error status and it is communicated properly,
- ⑦ When in the other station (station 2, 3) of the self station (station 1), the action mode of other station (station 4, 5) set in the parameter is RUN mode and not the error status and it is communicated properly.

If the above 7 items are satisfied, RUN-LINK of station 1 shall be ON. If using RUN-LINK contact associated with program in the system where PLC of various stations perform interlocking through High-speed Link, it is available to carry out the mutual monitoring of sending/receiving data and the reliable communication. But, once RUN-LINK contact is 'ON', it maintains 'ON' status until Link-Enable becomes 'OFF'. Thus when monitoring the abnormal status such as on communication error, it is required to use 'LINK-TROUBLE' information contact together as follows.

2) LINK-TROUBLE (`_PHSxLTRBL` x=High-speed Link no.(1~2))

This is the overall information indicating whether the High-speed Link is running normally by the parameter set by the user. When RUN-LINK violates the condition of RUN-LINK ON in the status that RUN-LINK is ON, LINK-TROUBLE shall be 'ON' and if recovered, it shall be 'OFF'.

3) High-speed Link status (`_PHSxSTATE[0..127]` x=the salve station no. (0~127))

This is the individual information indicating the action status of the slave station and this is available to indicate max. 127 stations High-speed Link status same as max. slave station number. That is, if the sending/receiving status of the corresponding list is normal and the action mode is RUN and there is no error, it shall be 'ON' and if violating the above condition, it shall be 'OFF'.

(2) High-speed Link information monitoring

High-speed Link information enables to monitor using the monitoring function after GMWIN online connecting. There are two kinds of method to monitor : the method to select 'variable monitor' from monitor menu and the method by link parameter monitor.

1) Variable monitor

The variable monitor is the function to monitor by using GMWIN flag monitor function and selecting the necessary item. If you select 'variable monitor' from online monitor item, the variable registration screen will appear as below. Select the flag and register by selecting directly the High-speed Link information flag from variable, flag list screen one by one. In this case, as PHSxSTATE[n] is Array type flag, the user should select the array no. directly and the array no. means the slave station no. Also, 'x' means the High-speed Link no. and it has the range 1~4 for GM3 PLC CPU, the range 1~2 for GM4 PLC CPU, and the range 1 for GM6 PLC CPU. If you register the variable in the figure below and select 'close', the monitor screen will appear and if you press 'start' from tool box shown on the right side separately, it begins to monitor.

High-speed Link information variable registration screen

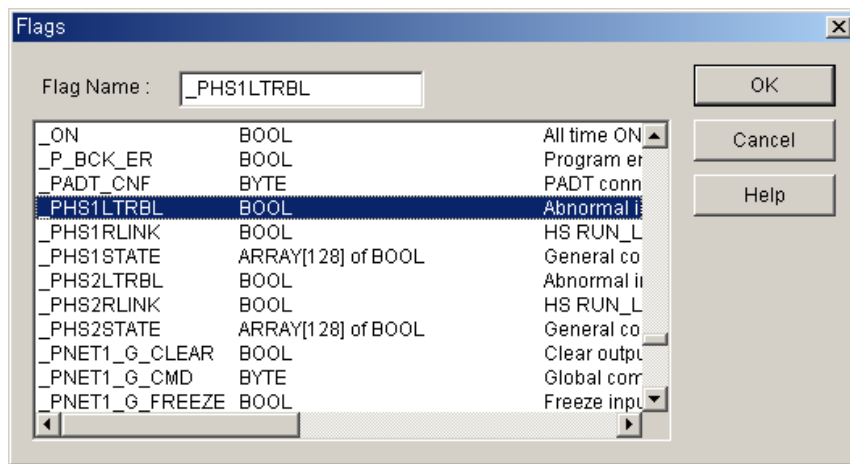

High-speed Link information monitor screen (Variable registration)

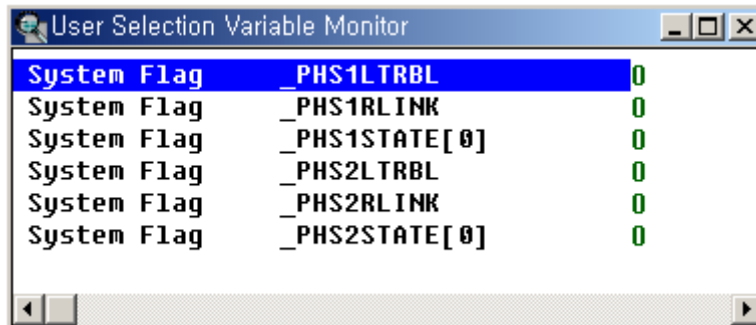

2) Link parameter monitor

If you select 'link parameter' item from monitor menu of GMWIN online connection, 'Select Link Parameter' screen will appear as shown on the figure below. If the user selects the desired item from parameter number set by himself and verify it, the High-speed Link parameter monitor screen will be open and the setting registration list will be monitored and indicated on the screen.

Link parameter selection screen

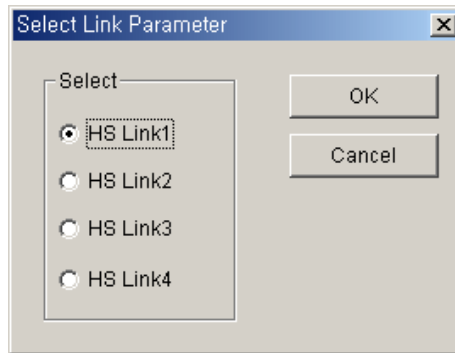

Link parameter monitor indicates the general information such as RUN-LINK, LINK-TROUBLE on the right top and the individual information for mode (action mode), communication (sending/receiving status), error with registration list no.

High-speed Link parameter monitor screen

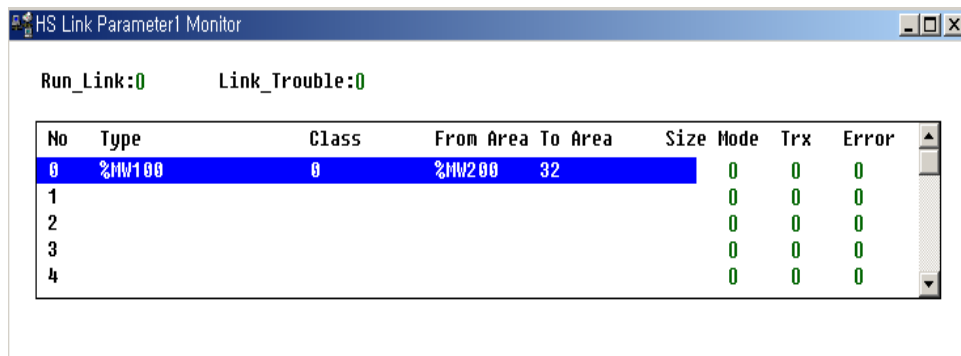

If selecting the High-speed Link information monitor as shown on the above figure, the High-speed Link parameter and information set by the user will be monitored together. And it is available to monitor the High-speed Link status with I/O data as the individual information setting value is monitored together.

5.3.13 High-speed Link Parameter Setting in KGLWIN

Profibus-DP master for MASTER-K also uses SyCon for the Configuration setting and the setting method is the same as that of GLOFA-GM. In case of MASTER-K, it should be required to set the High-speed Link parameter after downloading the Configuration to the master module and the High-speed Link parameter selects the parameter from KGLWIN project screen and set the corresponding item. The setting order and the function per item are as follows.

(1) High-speed Link parameter setting in KGLWIN

If selecting 'parameter' from the following project basic screen, the High-speed Link parameter basic screen will appear and you can select the corresponding item.

KGLWIN project basic screen

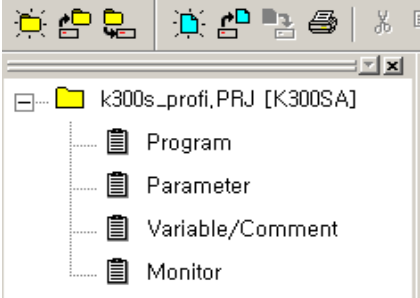

(2) High-speed Link parameter selection

1) Setting method

Select the corresponding parameter from the basic screen as shown on the figure below and enter into the parameter setting.

Parameter setting basic screen

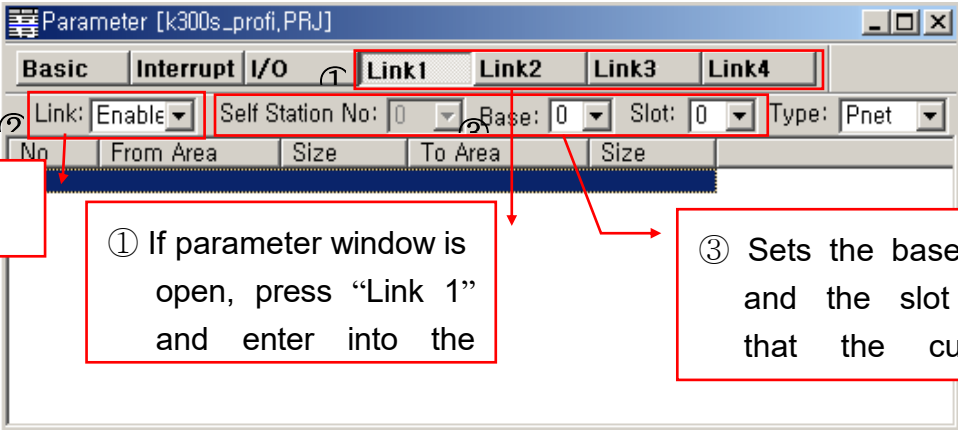

② Sets the

① If parameter window is open, press "Link 1" and enter into the

③ Sets the base No. and the slot No. that the current

The High-speed Link item tab of the above figure means max. installation number of communication module according to PLC CPU type. The High-speed Link button as much as the available setting number shall be active and in this case, the High-speed Link no. is not related to the installed slot no. and the slot no. shall be set in the individual parameter setting screen and only one High-speed Link parameter is available to set for one communication module.

The following table shows the communication model available to install per MASTER-K CPU model and max. installation number.

Max. installation number per MASTER-K CPU model

Classification	Available communication module	Max. installation number	Remarks
K1000S CPU	G3L-PUEA, G3L-PUEB	4	-
K300S CPU	G4L-PUEA, G4L-PUEB	2 /4 (Above version 3.0)	
K200S CPU	G6L-PUEA, G6L-PUEB	2	

* If combined with other communication module using the High-speed Link, the installation number shall be limited.

- Link: This is the item to allow the High-speed Link and the initial value is prohibited and it is required to set 'enable' to execute the High-speed Link.
 - Self station no. : Master module is set in SyCon and the slave module is set as rotary switch. It is not available to change here.
- Base: It sets the base position that the communication module to set is installed.
- Slot: It sets the position that the communication module to set is installed. (0 ~ 7 slot).
- Type: It sets the type of the installed communication module and sets the Pnet.

(3) Parameter setting and modification

If you double-click the corresponding parameter from the parameter setting basic screen as shown on the figure below, the High-speed Link parameter setting screen will appear.

Parameter setting initial screen

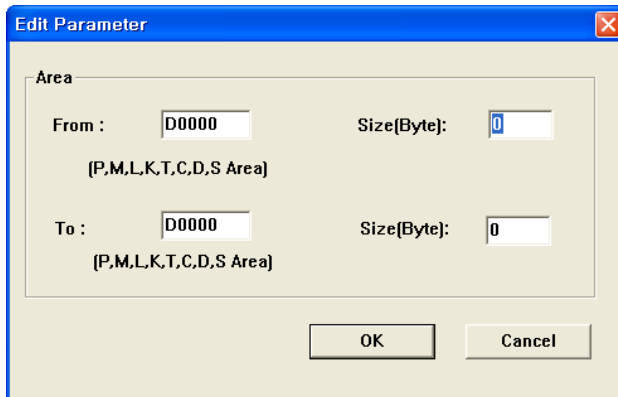

- Area: When sending, set the area to read the data to send and set the storage area of the received data when receiving.
- Size: This means the data size to send/receive and the unit is 1 byte and it is available to set total sending/receiving as 1Kbytes for G3/4/6L-PUEA and 7Kbytes for G3/4/6L-PUEB.

Remark

- 1) The size of sending/receiving area is the total I/O contact number made in SyCon.
- 2) The order of setting is carried out as G4L-PUEA 1 and GPL-TR2A(16 points), GPL-TR4A(32 points), GPL-D22A(16 points) and when setting sending area as P000, the receiving area as P010,
 - (1) Sending area : P000
 - (2) Receiving area : P010
 - (3) Size of sending area : 6 bytes(total output contact number)
 - (4) Size of receiving area : 2 bytes(total input contact number),
 And,
 - (5) P000 data -> GPL-TR2A output
 - (6) P001~P002 data -> GPL-TR4A output
 - (7) GPL-D22A input -> P010 saving.
- 3) The setting order programmed in SyCon has the priority when sending/receiving the data than station no. and cable connection.

5.3.14 High Speed Link Parameter setting in the XG5000

Set SyCon first and set XG5000.

If SyCon is not set or system is not configured normally, you can't communicate.

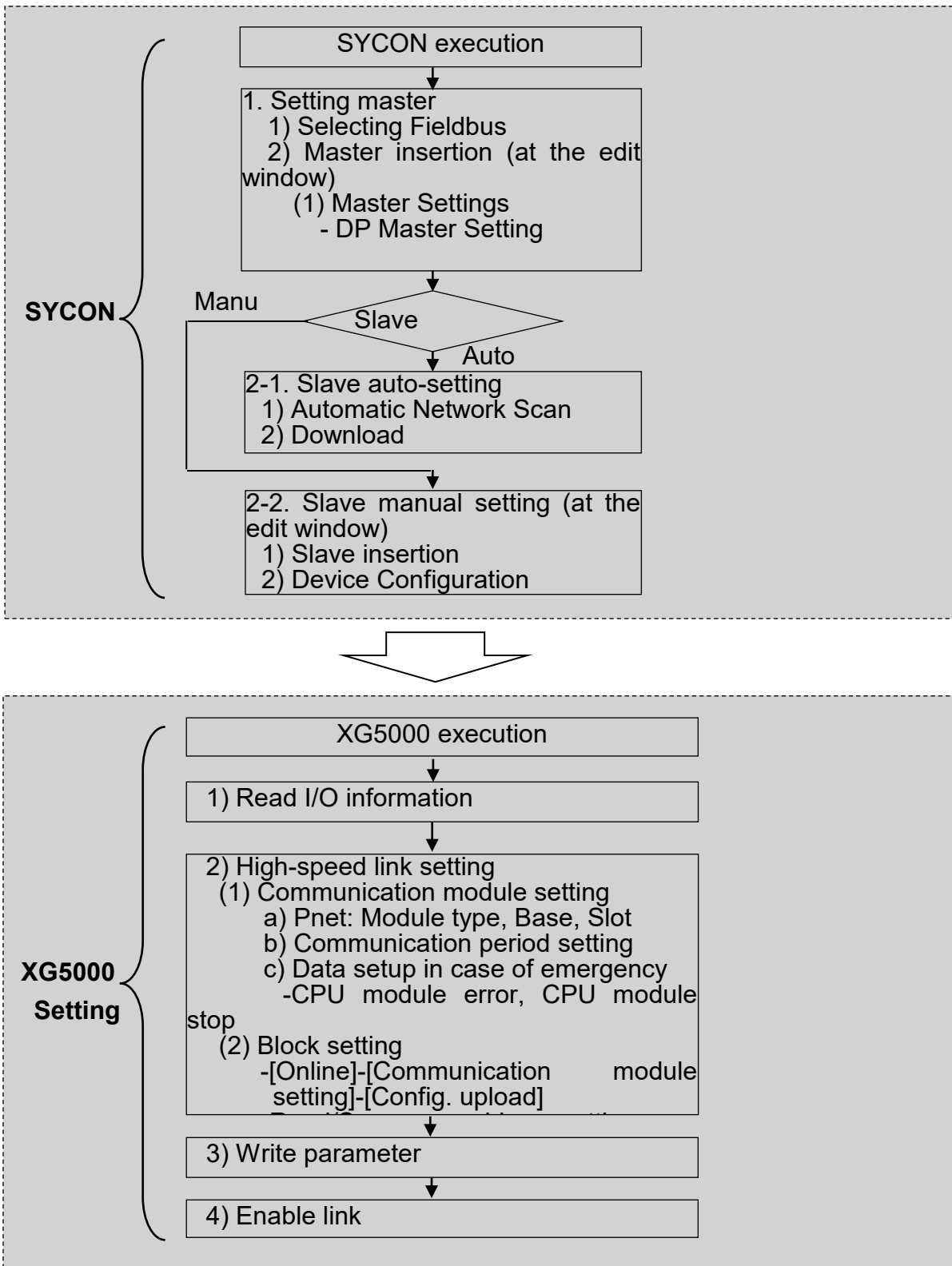

5.4 Analog I/O module Parameter Setting

5.4.1 XPL-BSSA Analog I/O module Parameter Setting

The type and parameter setting value of analog module available to be installed at XPL-BSSA are as follows.

Module type	Parameter setting	Contents		Remark
		I/O type	I/O range	
XBF-AD04A	0	0~10V	0~4,000	Initial value
	1	0~20mA	0~4,000	
	2	4~20mA	0~4,000	
	3	0~10V	-2,000~2,000	
	4	0~20mA	-2,000~2,000	
	5	4~20mA	-2,000~2,000	
	6	0~10V	0~1,000	
	7	0~20mA	0~1,000	
	8	4~20mA	0~1,000	
XBF-DV04A	0	0~10V	0~4,000	Initial value
	1	0~10V	0~1,000	
	2	0~10V	-2000~2000	
XBF-DC04A	0	4~20 mA	0 ~ 4,000	Initial value
	1	0~20 mA	0 ~ 4,000	
	2	4~20 mA	0 ~ 1,000	
	3	0~20 mA	0 ~ 1,000	
XBF-RD04A	0	pt100	Celsius	Initial value
	1	jpt100	Celsius	
	2	pt100	Fahrenheit	
	3	jpt100	Fahrenheit	
XBF-TC04S	0	K	Celsius	Initial value
	1	J		
	2	T		
	3	R		
	4	K	Fahrenheit	
	5	J		
	6	T		
	7	R		
XBF-AH04A, XBF-AD08A	0	1~5V	0~4,000	Initial value
	1		-2,000~2,000	
	2		Precise value ^{noe1)}	
	3		0~1000	
	4	0~5V	0~4,000	
	5		-2,000~2,000	
	6		Precise value	
	7		0~1000	
	8	0~10V	0~4,000	
	9		-2,000~2,000	
	10		Precise value	
11	0~1000			

Module type	Parameter setting	Contents		Remark
		I/O type	I/O range	
XBF-AH04A, XBF-AD08A	12	4~20mA	0~4,000	
	13		-2,000~2,000	
	14		Precise value	
	15		0~1000	
	16	0~20mA	0~4,000	
	17		-2,000~2,000	
	18		Precise value	
	19		0~1000	
XBF-AD04C	0	4~20mA	0~16,000	Initial value
	1		-8,000~8,000	
	2		Precise value	
	3		0~10,000	
	4	0~20mA	0~16,000	
	5		-8,000~8,000	
	6		Precise value	
	7		0~10,000	
	8	1~5V	0~16,000	
	9		-8,000~8,000	
	10		Precise value	
	11		0~10,000	
	12	0~5V	0~16,000	
	13		-8,000~8,000	
	14		Precise value	
	15		0~10,000	
	16	0~10V	0~16,000	
	17		-8,000~8,000	
	18		Precise value	
	19		0~10,000	
	20	-10~10V	0~16,000	
	21		-8,000~8,000	
	22		Precise value	
23	0~10,000			
XBF-DV04C	0	1~5V	0~16,000	Initial value
	1		-8,000~8,000	
	2		Precise value	
	3		0~10,000	
	4	0~5V	0~16,000	
	5		-8,000~8,000	
	6		Precise value	
	7		0~10,000	
	8	0~10V	0~16,000	
	9		-8,000~8,000	
	10		Precise value	
	11		0~10,000	
	12	-10~10V	0~16,000	
	13		-8,000~8,000	
	14		Precise value	
15	0~10,000			

Module type	Parameter setting	Contents		Remark
		I/O type	I/O range	
XBF-DC04C	0	4~20mA	0~16,000	Initial value
	1		-8,000~8,000	
	2		Precise value	
	3		0~10,000	
	4	0~20mA	0~16,000	
	5		-8,000~8,000	
	6		Precise value	
	7		0~10,000	

5.4.2 How to set XPL-BSSA analog I/O module parameter

How to set the analog parameter of XPL-BSSA is classified into two methods according to master module type. (Setting at Sycon and Setting at nConfigurator). For G4L-PUEC and XGK-PMEB/C, nConfigurator is used. And for other modules, Sycon is used for parameter setting

(1) Setting at SYCON

a) Double click XPL-BSSA as below

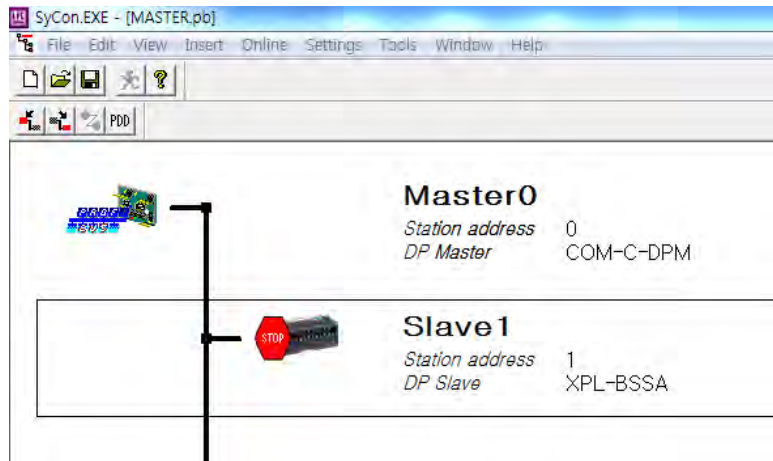

b) Click the [Parameter Data] at [Slave Configuration]

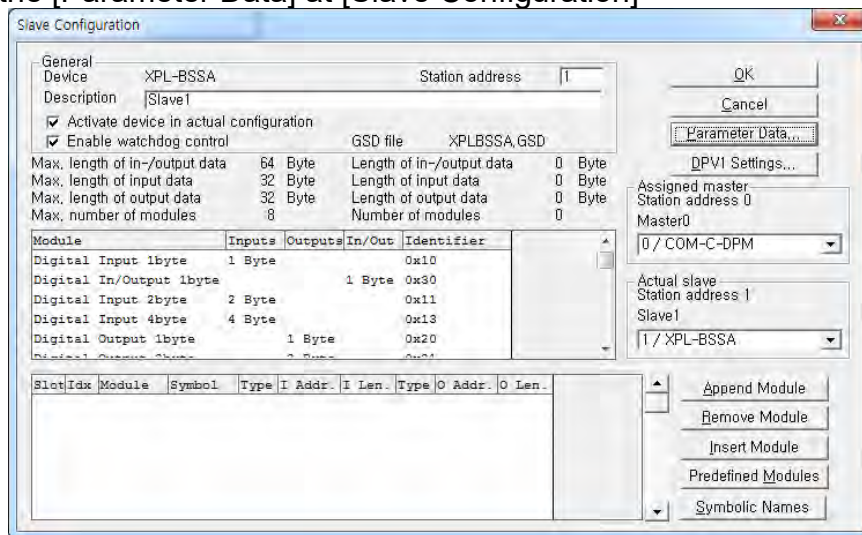

c) Set a parameter per each slot at parameter data. For parameter input, double click the slot. At this time, parameter input value is decimal number

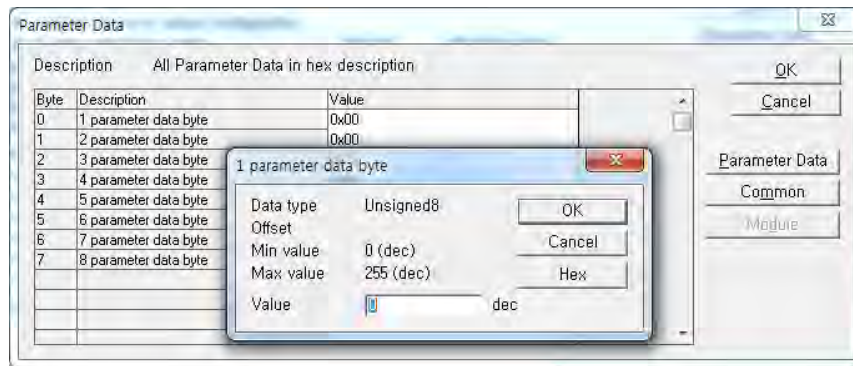

- d) After parameter setting is complete, download to a master module
 - 1) In case network is not set
After executing [SYCON]-[Online]-[Download], complete through high-speed link parameter setting of XG5000.
 - 2) In case of changing a parameter while network setting is completed
Complete through [SYCON]-[Online]-[Start Communication]

(2) Setting at nConfigurator

Click XPL-BSSA and then click [Configuration]-[Parameter settings] in menu.

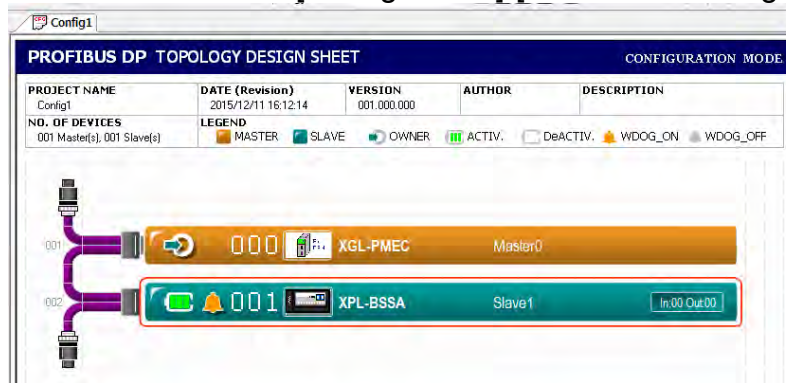

a) Click a [Parameter Data] at [Slave Configuration]

Set a parameter per each slot at Parameter Value. For parameter input, click Decimal and input a parameter. At this time, input value of each parameter is decimal number.

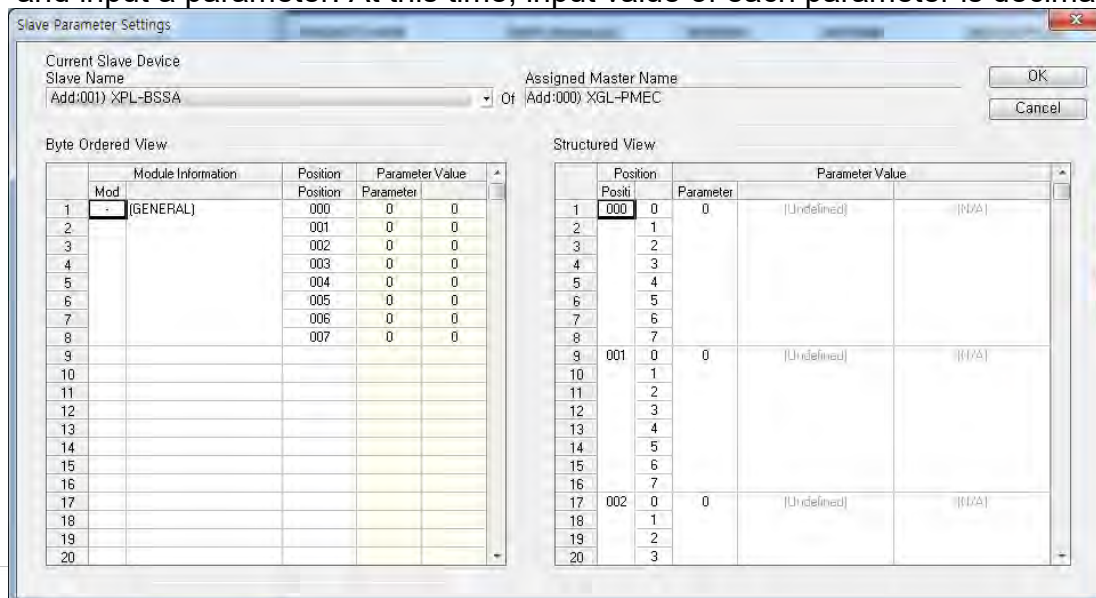

Note

- Caution in setting an analog parameter

(1) Each parameter setting is necessary for each analog module.

(2) If you don't set any parameter, module operates with initial parameter value.

(3) The parameter is sent from master to slave.

▶ Slave keeps previous value while cable is connected, regardless of power on/off.

▶ If you restart the power while cable is not connected, module operated with initial value.

5.5 Program example

5.5.1 GLOFA-GM series

1) Program example – Communication between G4L-PUEA and Smart I/O Pnet modules

The basic configuration and setting value is as follows

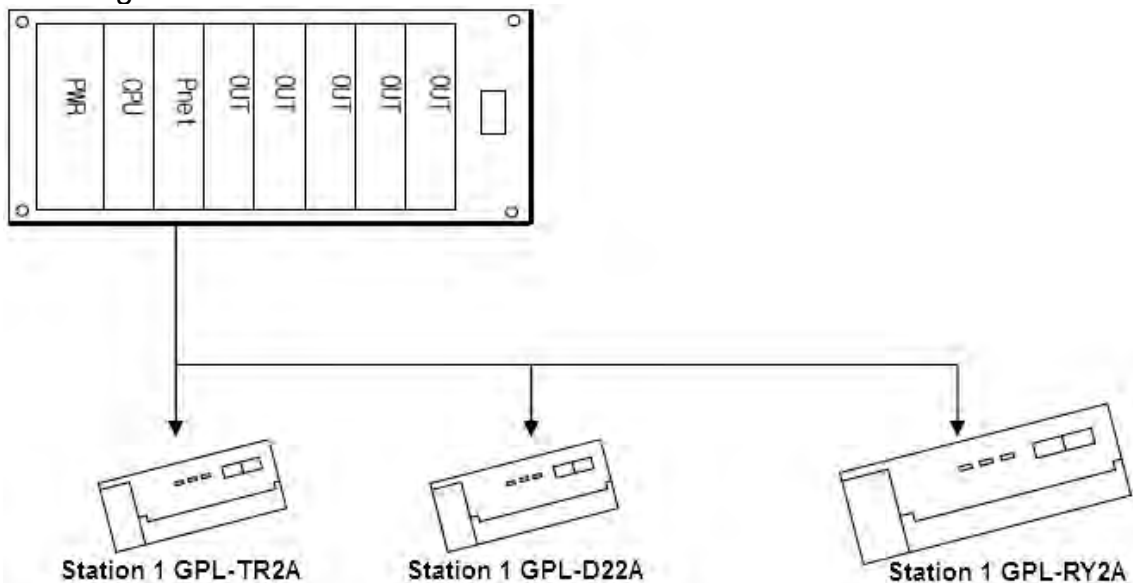

Setting category		Contents		Setting Program		
System configuration	Master	Master setting		G4L-PUEA	SYCON	
		Base no.		0	GMWIN	
		Slot no.		0	GMWIN	
		Station no.		0	SYCON	
		Communication speed		1.5Mbps	SYCON	
		HSL setting		Use HSL 1	GMWIN	
	Slave	Slave selection		GPL-TR2A, GPL-D22A, GPL-RY2A		SYCON
		GPL-TR2A Output 16 points	Station no.	1		SYCON
			Read area	Device	%MW0	GMWIN
			Size	2		
		GPL-D22A Input 16 points	Station no.	2		SYCON
			Save area	Device	%QW0.2.0	GMWIN
	Size	2				
GPL-RY2A Output 16 points	Station no.	3		SYCON		
	Read area	Device	%MW1	GMWIN		
	Size	2				
Etc.	Master setting		Modification of default value		SYCON	
	Device Assignment		Setting communication port of PC		SYCON	

- System configuration

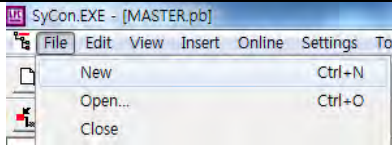
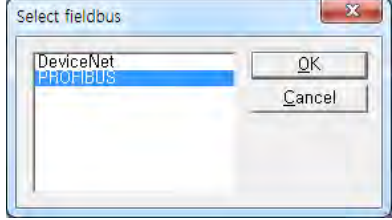

[SYCON 1st step] Master and station no. setting

Menu setting: [File] – [New]

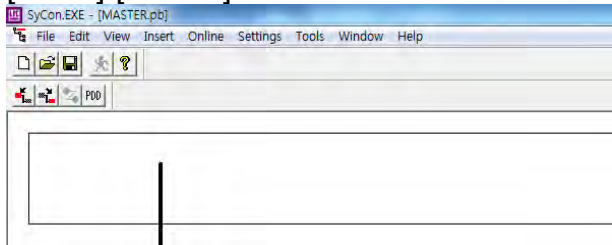
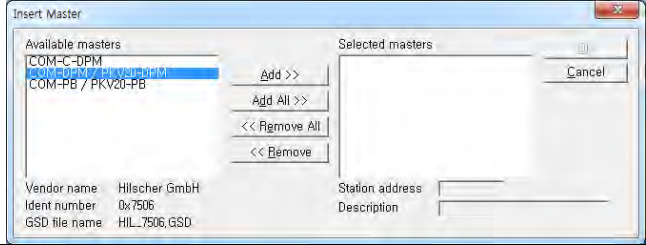
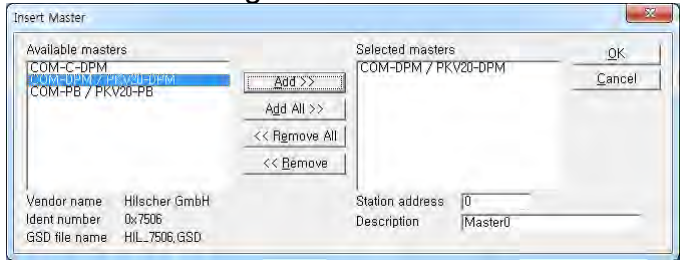
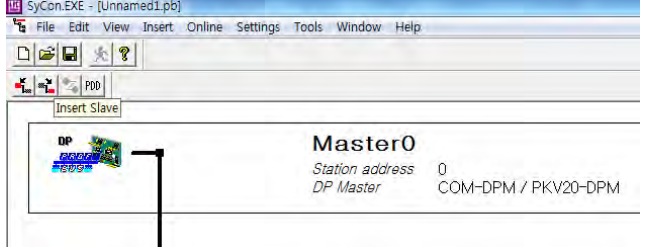
Step	Category	Screen formation and setting contents
1-1	Make a new file	 <p>New file writing</p>
1-2	Select PROFIBUS	 <p>PROFIBUS selection</p>
1-3	Master setting	<p>Recall master setting window</p> <p>[Insert]-[Master] or </p> 
1-4	Master insertion	<p>Master type selection: COM-DPM / PKV20-DPM</p> 
1-5	Station no setting	<p>Station no. setting: 0</p> 
1-6	Master setting completion	 <p>Master0 Station address 0 DP Master COM-DPM / PKV20-DPM</p>

[SYCON 2nd step] Setting of slave and station number

Menu selection: [Insert] – [Slave]

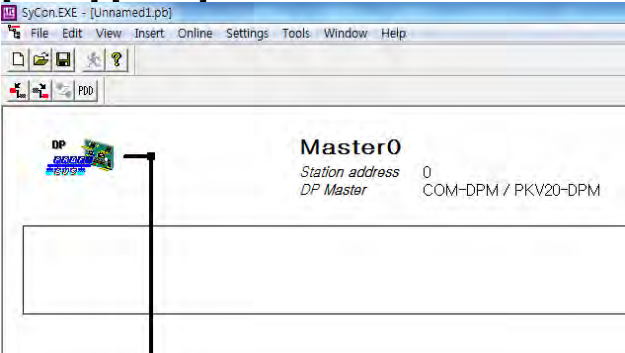
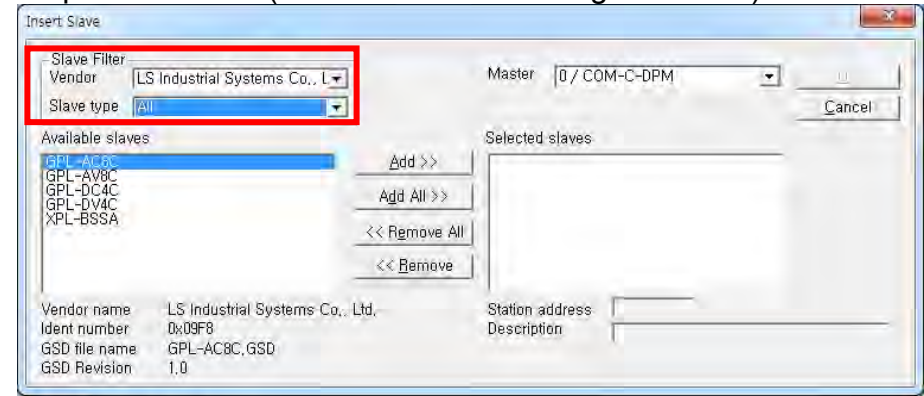
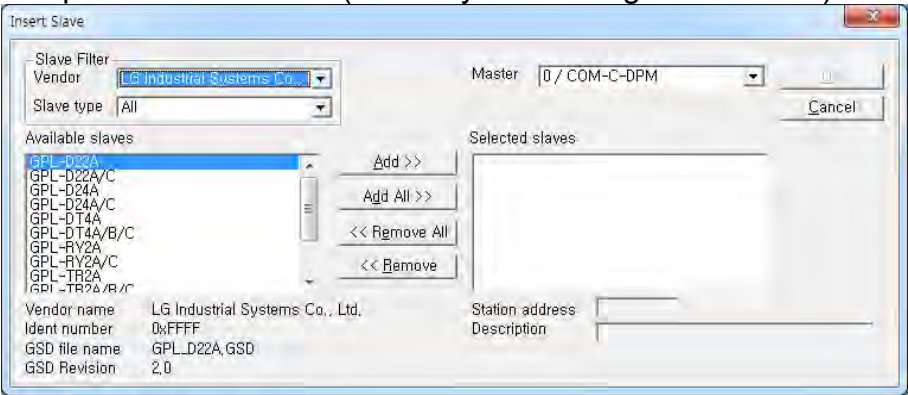
Step	Category	Screen formation and setting contents
2-1	Slave setting	<p>Recall master setting window. [Insert]-[Slave] or </p> 
2-2	Slave selection	<p>1step: Slave Filter (classification according to vendor)</p>  <p>2step: Available Device (select system configuration slave)</p> 

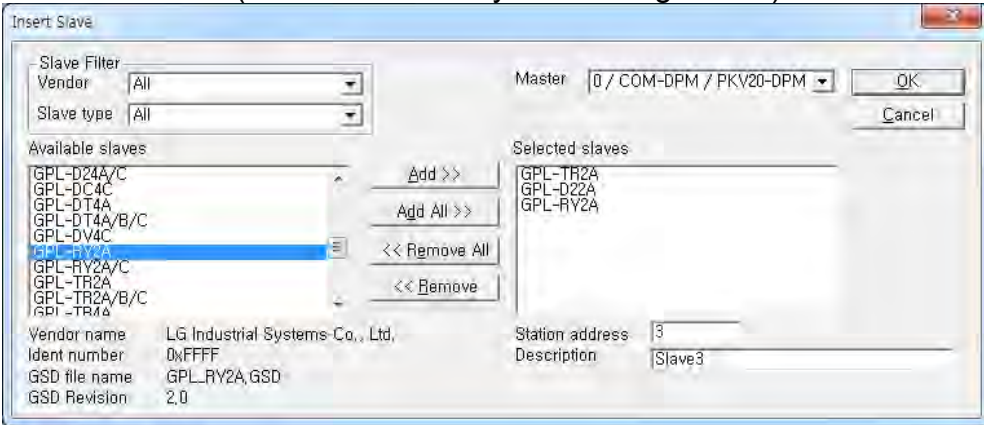
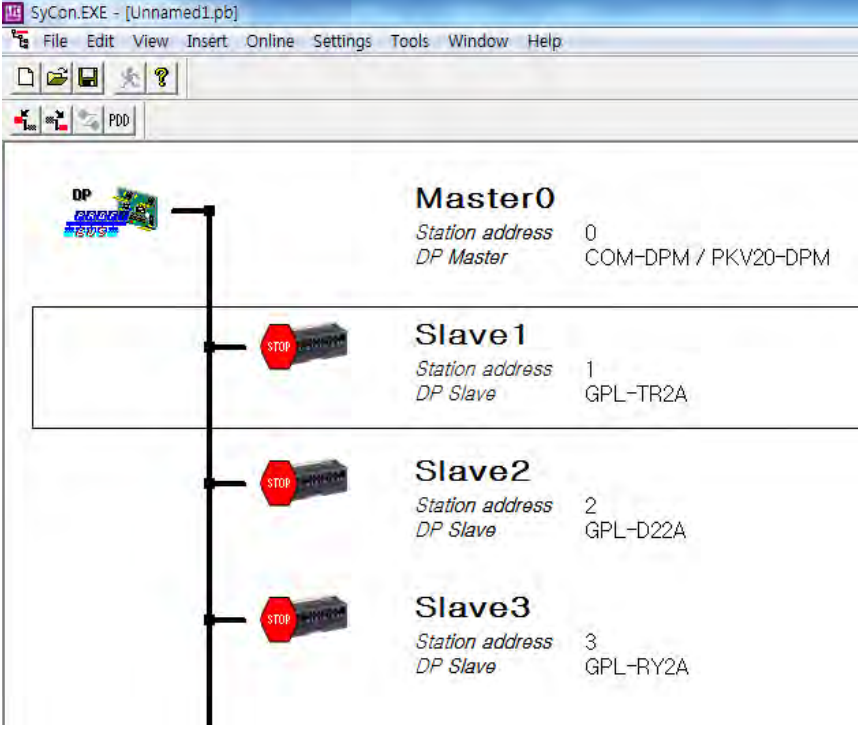
Step	Category	Screen configuration and setting contents															
2-3	Station address setting	<p>Station Address (Set slave no. of system configuration)</p> 															
2-4	Completion of slave setting	 <table border="1" data-bbox="839 1071 1257 1575"> <thead> <tr> <th>Station Name</th> <th>Station address</th> <th>DP Slave</th> </tr> </thead> <tbody> <tr> <td>Master0</td> <td>0</td> <td>COM-DPM / PKV20-DPM</td> </tr> <tr> <td>Slave1</td> <td>1</td> <td>GPL-TR2A</td> </tr> <tr> <td>Slave2</td> <td>2</td> <td>GPL-D22A</td> </tr> <tr> <td>Slave3</td> <td>3</td> <td>GPL-RY2A</td> </tr> </tbody> </table>	Station Name	Station address	DP Slave	Master0	0	COM-DPM / PKV20-DPM	Slave1	1	GPL-TR2A	Slave2	2	GPL-D22A	Slave3	3	GPL-RY2A
Station Name	Station address	DP Slave															
Master0	0	COM-DPM / PKV20-DPM															
Slave1	1	GPL-TR2A															
Slave2	2	GPL-D22A															
Slave3	3	GPL-RY2A															

[SYCON 3rd step] Serial port selection: It is same with RS-232C's wiring used in CPU module. Please use that cable.

Menu selection: [Settings] – [Device Assignment]

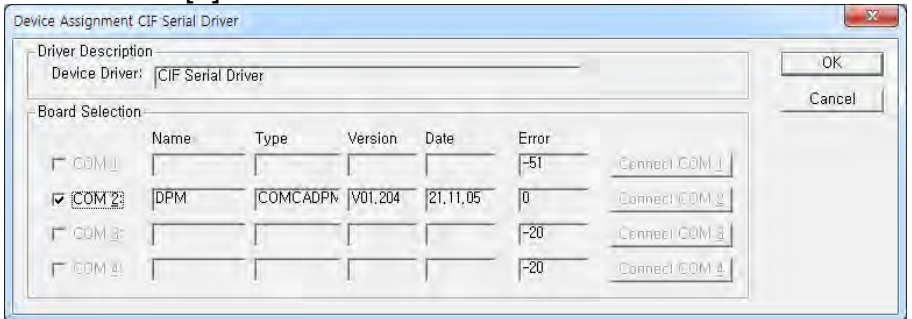
Step	Category	Screen configuration and setting contents
3-1	Setting window for serial port	<p>Serial port</p> 
3-2	Port research	<p>[Connect COM] In activated port among COM 1~4, error value is indicated as [0]</p>  <p>Marking activated port and select [OK]</p>

[SYCON 4th step] Download
Menu selection: [OnLine] – [Download]

Note

- 1) Set the size of read and save area in GMWIN same as in SYCON. When select the Smart I/O module in SYCON, size of each module's read and save area are set automatically. (You can check it in the Slave setting window)
- 2) Set as sequence of G4L-PUEA, GPL-TR2A(16points), GPL-D22A(16points), GPL-RY2A(16points) and set the read area as %MW0, save area as %MW100.
 - (1) Read area: %MW0
 - (2) Save area: %QW0.2.0
 - (3) Size of read area: 4 bytes (whole number of output points)
 - (4) Size of save area: 2 bytes(whole number of input points)
 - (5) %MW0 data -> GPL-TR2A
 - (6) %MW1 data -> GPL-RY2A
 - (7) Input of GPL-D22A -> %QW0.2.0
- 3) Either GMWIN program and SYCON setting can be set first.

[GMWIN 1st step] Programming

Step	Category	Screen configuration and setting contents
1-1	Programming	

[GMWIN 2nd step] High speed link setting in master module

Step	Category	Screen configuration and setting contents
2-1	High speed link setting (1)	
		Double click the [LINK parameter] in parameter tab and select [High speed link 1]
2-2	High speed link setting (2)	
		Click [Edit] in [High speed link 1] window and set network type and slot no.

[GMWIN 3rd step] Slave parameter setting

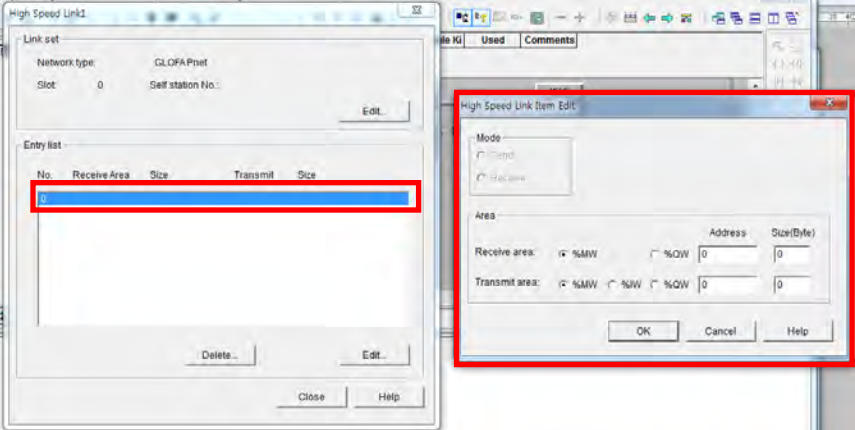
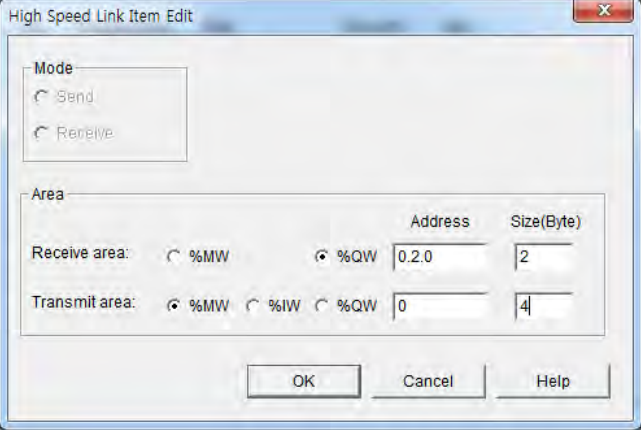
Step	Category	Screen configuration and setting contents
3-1	Transmit/Receive area setting (1)	 <p>Double click the part of No.1 in [High speed link 1] window</p>
3-2	Transmit/Receive area setting (2)	 <ul style="list-style-type: none"> - Receive area: %QW0.2.0, 2bytes - Transmit area: %MW0, 4bytes

5.5.2 Mater-K series

1) Program example – Communication between G4L-PUEA and Smart I/O Pnet modules

The basic configuration and setting value is as follows

Setting category		Contents		Setting Program	
System configuration	Master	Master setting		G4L-PUEA	SYCON
		Base no.		0	KGLWIN
		Slot no.		0	KGLWIN
		Station no.		0	SYCON
		Communication speed		1.5Mbps	SYCON
		HSL setting		Use HSL 1	KGLWIN
	Slave	Slave selection		GPL-TR2A, GPL-D22A, GPL-RY2A	SYCON
		GPL-TR2A Output 16 points	Station no.	1	SYCON
			Read area	Device: P0004 Size: 2	KGLWIN
		GPL-D22A Input 16 points	Station no.	2	SYCON
Save area			Device: M0000 Size: 2	KGLWIN	
GPL-RY2A Output 16 points		Station no.	3	SYCON	
	Read area	Device: P0005 Size: 2	KGLWIN		
Etc.	Master setting		Modification of default value	SYCON	
	Device Assignment		Setting communication port of PC	SYCON	

- System configuration

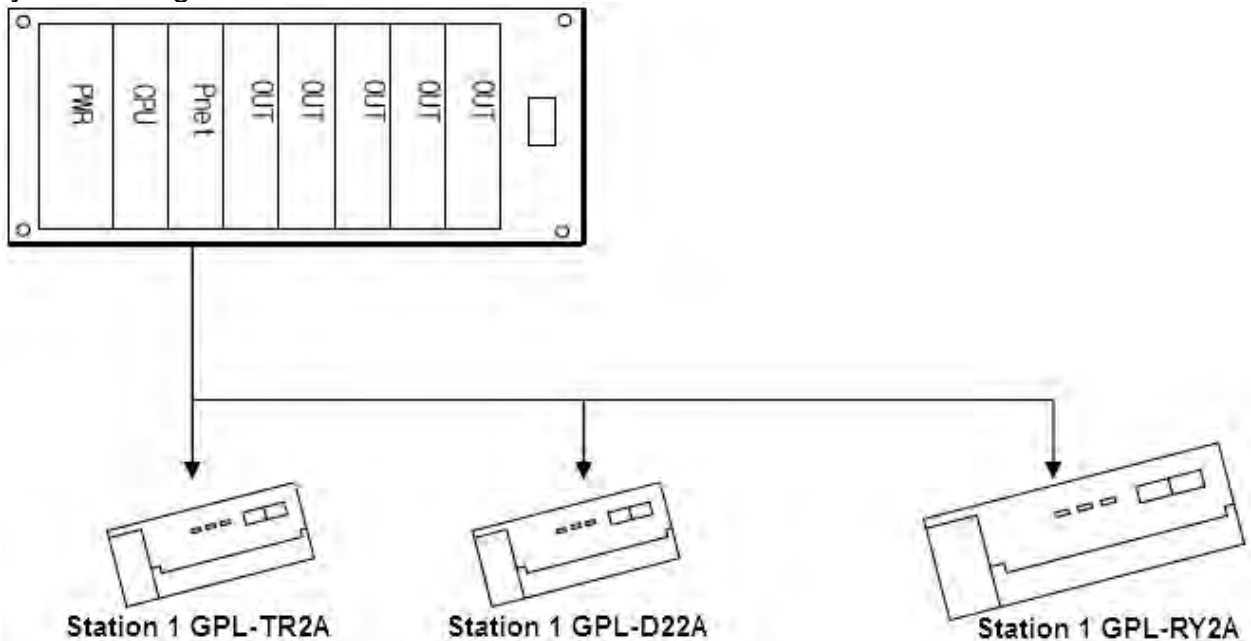

SYCON setting is same with example of GLOFA-GM series.

[KGLWIN 1st step] Programming

Step	Category	Screen configuration and setting contents
1-1	Programming	

[KGLWIN 2nd step] High speed link setting in master module

Step	Category	Screen configuration and setting contents																																																																																																																																								
2-1	High speed link setting (1)	<p>Double click [Parameter] menu on the project tree</p>																																																																																																																																								
2-2	High speed link setting (2)	<p>Select [Link1] tab and set Link(Enable), Self Station No(0), Base and slot, Type(Pnet)</p> <table border="1"> <thead> <tr> <th>No</th> <th>Station</th> <th>Unit Type</th> <th>Tx Device</th> <th>Rx Device</th> <th>Size</th> <th>Block No</th> <th>Period</th> </tr> </thead> <tbody> <tr> <td>0</td> <td></td> <td></td> <td></td> <td></td> <td></td> <td></td> <td></td> </tr> <tr> <td>1</td> <td></td> <td></td> <td></td> <td></td> <td></td> <td></td> <td></td> </tr> <tr> <td>2</td> <td></td> <td></td> <td></td> <td></td> <td></td> <td></td> <td></td> </tr> <tr> <td>3</td> <td></td> <td></td> <td></td> <td></td> <td></td> <td></td> <td></td> </tr> <tr> <td>4</td> <td></td> <td></td> <td></td> <td></td> <td></td> <td></td> <td></td> </tr> <tr> <td>5</td> <td></td> <td></td> <td></td> <td></td> <td></td> <td></td> <td></td> </tr> <tr> <td>6</td> <td></td> <td></td> <td></td> <td></td> <td></td> <td></td> <td></td> </tr> <tr> <td>7</td> <td></td> <td></td> <td></td> <td></td> <td></td> <td></td> <td></td> </tr> <tr> <td>8</td> <td></td> <td></td> <td></td> <td></td> <td></td> <td></td> <td></td> </tr> <tr> <td>9</td> <td></td> <td></td> <td></td> <td></td> <td></td> <td></td> <td></td> </tr> <tr> <td>10</td> <td></td> <td></td> <td></td> <td></td> <td></td> <td></td> <td></td> </tr> <tr> <td>11</td> <td></td> <td></td> <td></td> <td></td> <td></td> <td></td> <td></td> </tr> <tr> <td>12</td> <td></td> <td></td> <td></td> <td></td> <td></td> <td></td> <td></td> </tr> <tr> <td>13</td> <td></td> <td></td> <td></td> <td></td> <td></td> <td></td> <td></td> </tr> <tr> <td>14</td> <td></td> <td></td> <td></td> <td></td> <td></td> <td></td> <td></td> </tr> <tr> <td>--</td> <td></td> <td></td> <td></td> <td></td> <td></td> <td></td> <td></td> </tr> </tbody> </table>	No	Station	Unit Type	Tx Device	Rx Device	Size	Block No	Period	0								1								2								3								4								5								6								7								8								9								10								11								12								13								14								--							
No	Station	Unit Type	Tx Device	Rx Device	Size	Block No	Period																																																																																																																																			
0																																																																																																																																										
1																																																																																																																																										
2																																																																																																																																										
3																																																																																																																																										
4																																																																																																																																										
5																																																																																																																																										
6																																																																																																																																										
7																																																																																																																																										
8																																																																																																																																										
9																																																																																																																																										
10																																																																																																																																										
11																																																																																																																																										
12																																																																																																																																										
13																																																																																																																																										
14																																																																																																																																										
--																																																																																																																																										

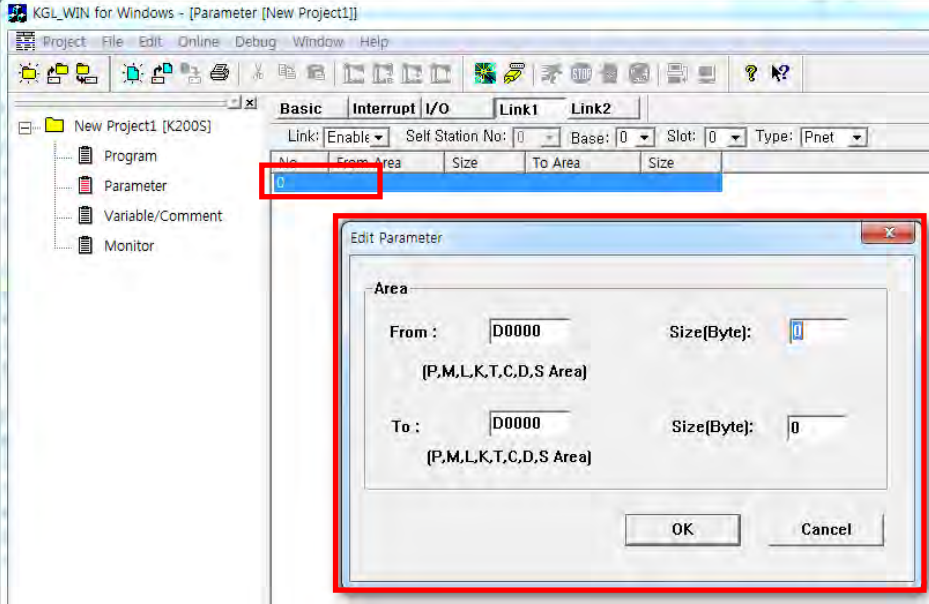
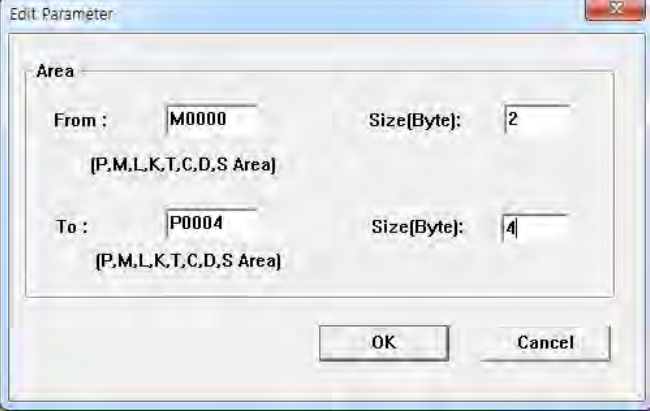
Step	Category	Screen configuration and setting contents
2-3	High speed link setting (3)	 <p>Double click the part of No.1 in [Link1] tab</p>
2-4	High speed link setting (4)	 <p>- Receive area: M0000, 2bytes - Transmit area: P0004, 4bytes</p>

5.5.3 XGT series communication

1) Program example – communication between our Smart I/O Pnet modules

The basic configuration and setting value is as follows.

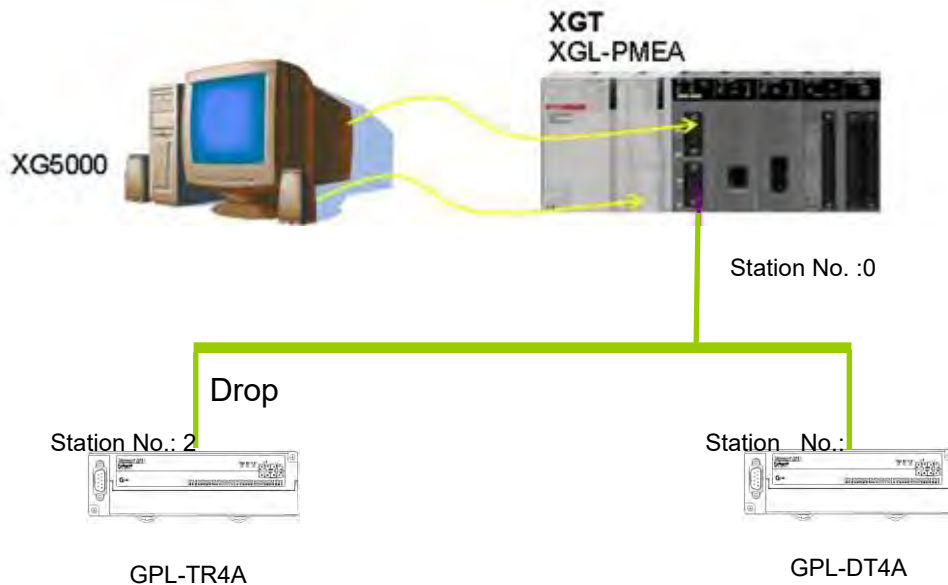

Setting category		Contents		Setting program
System configuration	master	Master setting		SyCon
		Base No.		XG5000
		Slot No.		XG5000
		Station No.		SyCon
		Communication speed		SyCon
		HSL setting		XG5000
		Communication period setting		XG5000
	slave	Slave selection		SyCon
		GPL-TR4A Output 32point	Station No.	XG5000
			Read area	XG5000
GPL-DT4A Output 16 point Input 16 point		Station No.	SyCon	
		Save area	Device	XG5000
			Size	XG5000
	Read area	Device	XG5000	
Size		XG5000		
Etc.	Master Setting		SyCon	
	Device Assignment		SyCon	

• System configuration

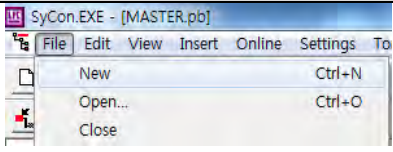
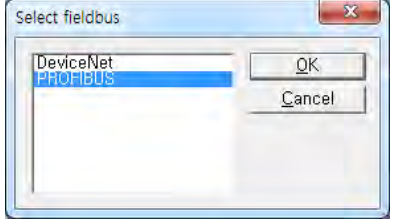

[SYCON 1st step] Master and station no. setting

Menu selection: [File] – [New]

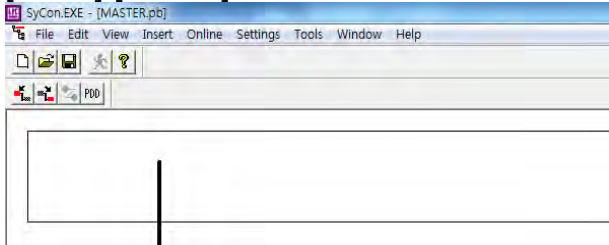
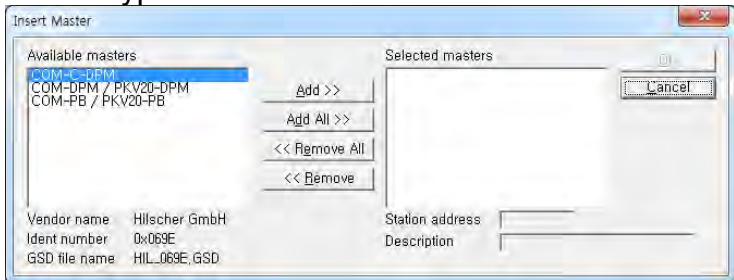
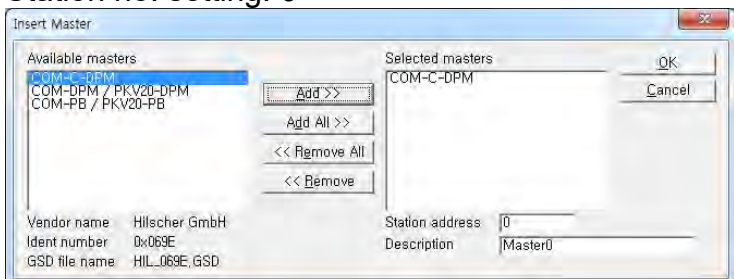
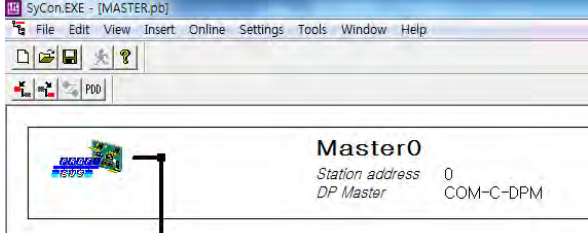
Step	Category	Screen formation and setting contents
1-1	Make a new file	 <p>New file writing</p>
1-2	Select PROFIBUS	 <p>PROFIBUS selection</p>
1-3	Master setting	<p>Recall master setting window</p> <p>[Insert]-[Master] or </p> 
1-4	Master insertion	<p>Master type selection: COM-C-DPM</p> 
1-5	Station no setting	<p>Station no. setting: 0</p> 
1-6	Master setting completion	 <p>Master0 Station address 0 DP Master COM-C-DPM</p>

[SYCON 2nd step] Basic setting modification

Menu selection: [Insert] – [Slave]

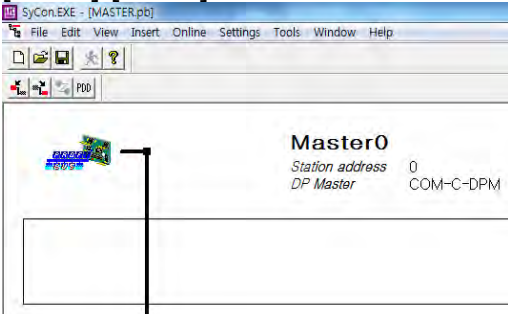
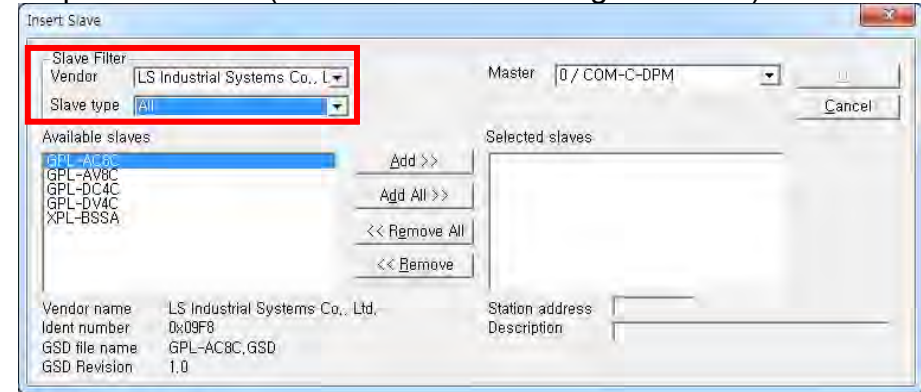
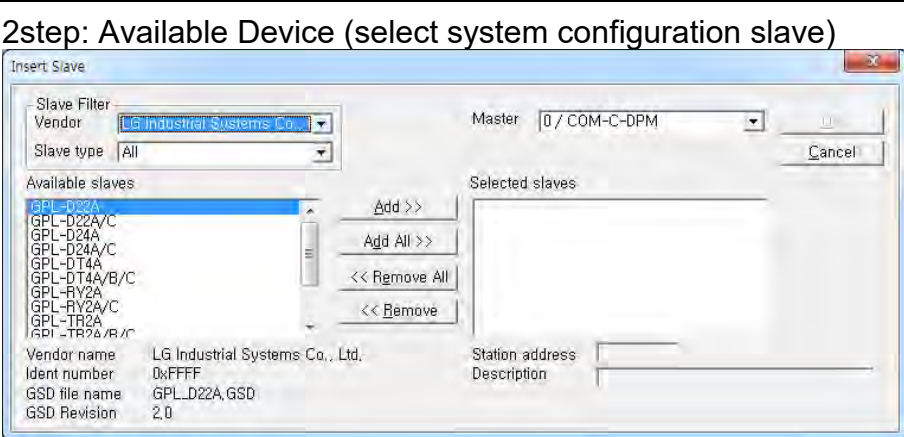
Step	Category	Screen formation and setting contents
2-1	Slave setting	<p>Recall master setting window. [Insert]-[Slave] or </p> 
2-2	Slave selection	<p>1step: Slave Filter (classification according to vendor)</p>  <p>2step: Available Device (select system configuration slave)</p> 

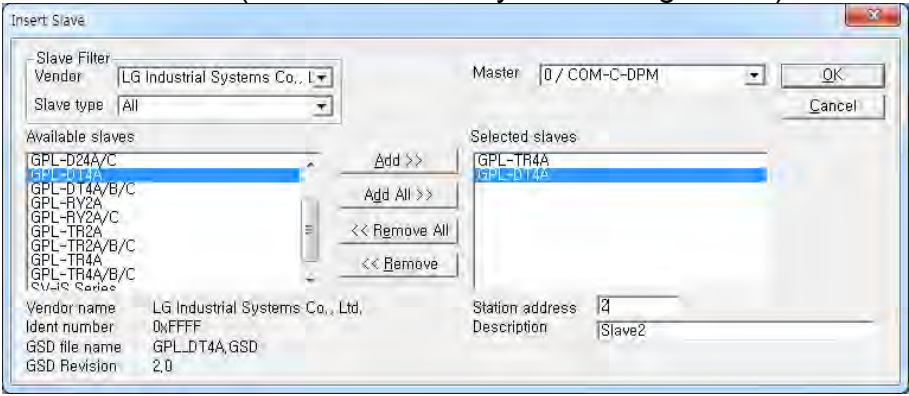
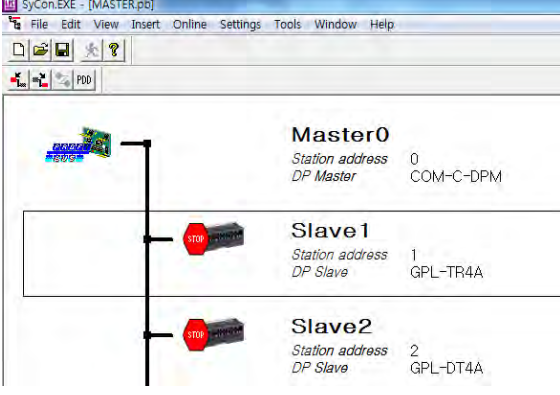
Step	Category	Screen configuration and setting contents
2-3	Station address setting	<p>Station Address (Set slave no. of system configuration)</p> 
2-4	Completion of slave setting	

[SYCON 3rd step] Serial port selection: It is same with RS-232C's wiring used in CPU module. Please use that cable.

Menu selection: [Settings] – [Device Assignment]

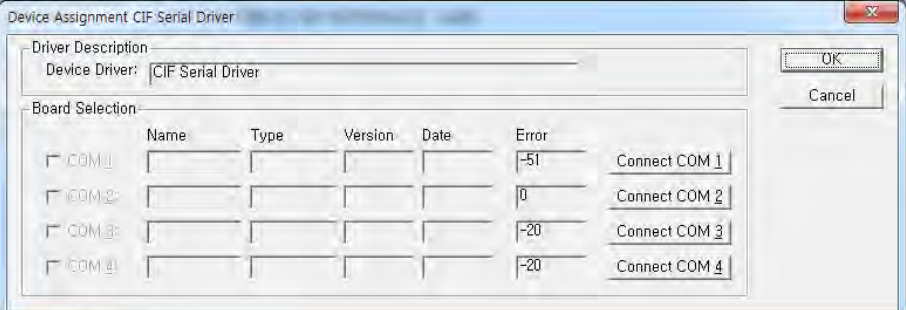
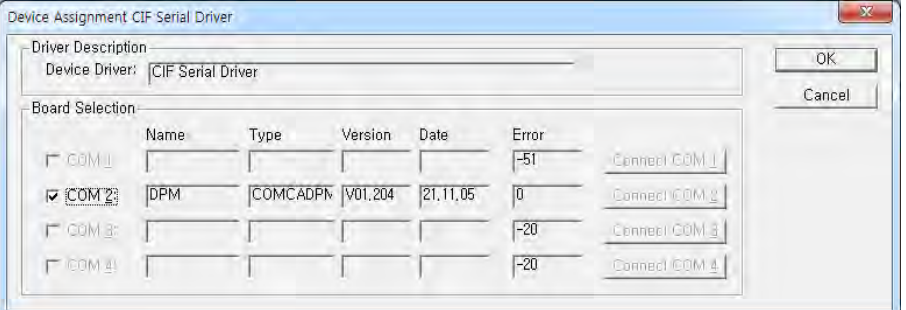
Step	Category	Screen configuration and setting contents
3-1	Setting window for serial port	<p>Serial port</p> 
3-2	Port research	<p>[Connect COM] In activated port among COM 1~4, error value is indicated as [0]</p>  <p>Marking activated port and select [OK]</p>

[SYCON 4th step] Download

Menu selection: [OnLine] – [Download]

[XG5000 1st step] Select type of CPU module

Menu selection: [Option] – [PLC type setting]

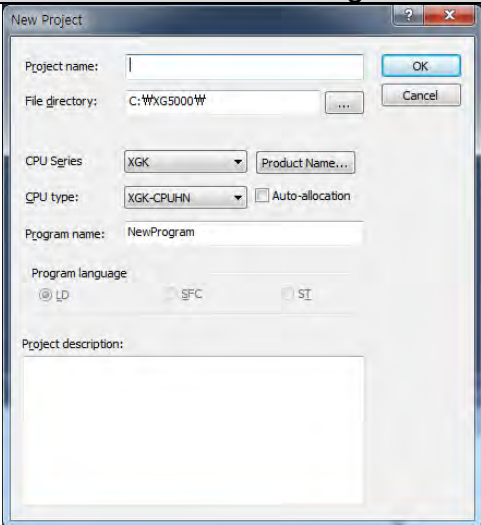
Step	Category	Screen configuration and setting contents
1-1	CPU module selection	

[XG5000 2nd step] Communication method setting

Menu selection: [Online] – [Connection setting]

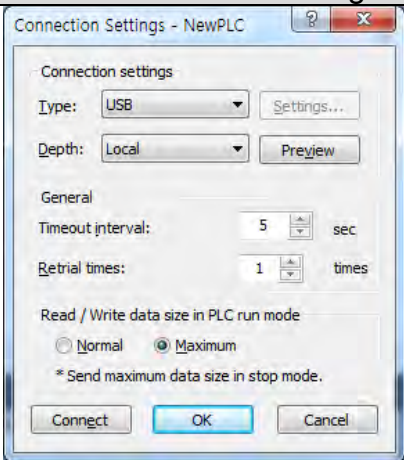
Step	Category	Screen configuration and Setting contents
2-1	Connection Settings	 <p>Connecting Type: USB Connecting Depth: local</p>

[XG5000 3rd step] Connection

Menu selection: [Online] – [Connection]

[XG5000 4th step] I/O information reading

Menu selection: [Online] – [Diagnosis] – [I/O Information] – [I/O Sync]

[XG5000 5th step] High-speed Link setting

Menu selection: Right click the XGL-PMEA module and select [Add Item] – [High-speed link communication]

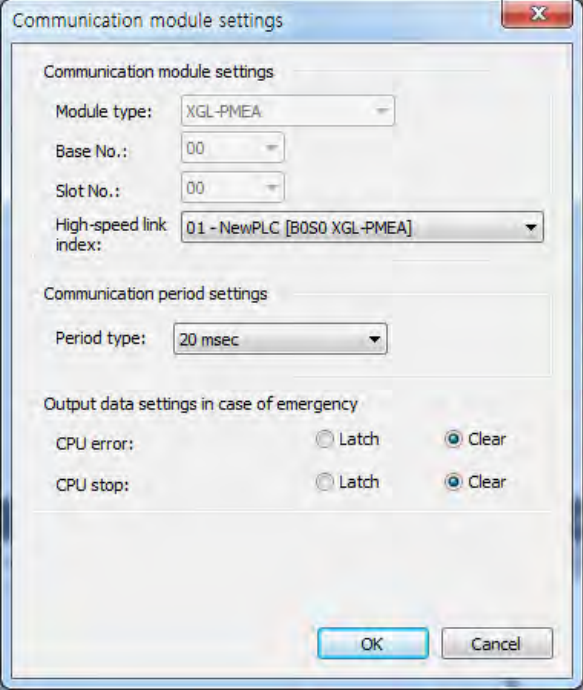
Step	Category	Screen configuration and setting contents
5-1	Communication module setting	<p>Initial screen</p> 

[XG5000 6-1st step] SYCON upload

Menu selection: [Online] – [SYCON upload (Pnet, Dnet)]

Step	Category	Screen configuration and setting contents
6-1	Communication module setting	Initial screen
		SYCON upload

[XG5000 6-2nd step] Read area / Save area setting

Menu selection: Double click the [High-speed link 01] in the project tree

Step	Category	Screen configuration and setting contents
6-1	Communication module setting	Initial screen
		High speed link block after set read/write area

[XG5000 7th step] Write High-speed link parameter

Menu selection: [Online] – [Write]

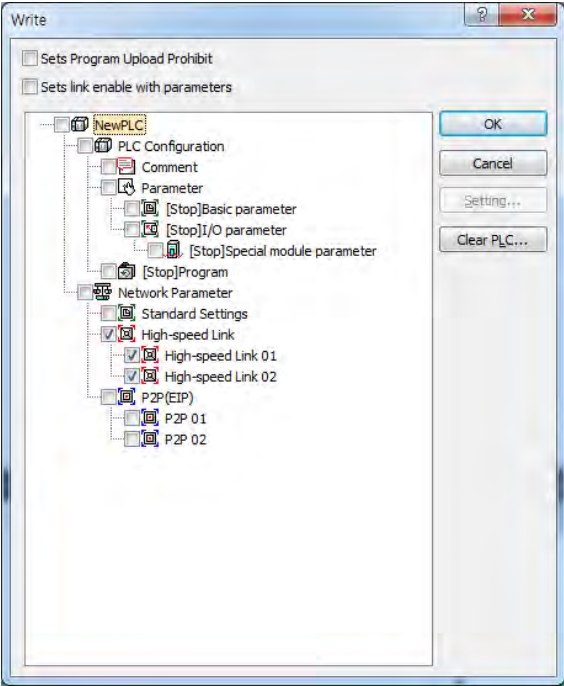
Step	Category	Screen configuration and setting contents
7-1	Write parameter	<p>Select High-speed link</p>  <p>- Press [OK], parameter is downloaded.</p> <p>- The data of parameter writing is stored in CPU module. So you should back-up High-speed link parameter when changing CPU module.</p>

[XG5000 8th step] Enable High-speed link

Menu selection: [Online] – [Communication module setting] – [Enable Link (HS link, P2P)]

2) Program example – communication between XGL-PMEA and extantion type Smart I/O Pnet module

The basic configuration and setting value is as follows

Setting category		Contents		Setting Program	
System configuration	Master	Master setting		SYCON	
		Base no.		XG5000	
		Slot no.		XG5000	
		Station no.		SYCON	
		Communication speed		SYCON	
		HSL setting		XG5000	
		Communication period setting		XG5000	
	Slave	Slave selection		SYCON	
		XPL-BSSA XBE-TN32A: Tr out	Station no.	3	SYCON
			Save area	Device	P1000
Size		14			
XBE-DC32A: DC input		Read area	Device	M200	XG5000
	Size		12		
Etc.	Master setting		Modification of default value	SYCON	
	Device Assignment		Setting communication port of PC	SYCON	

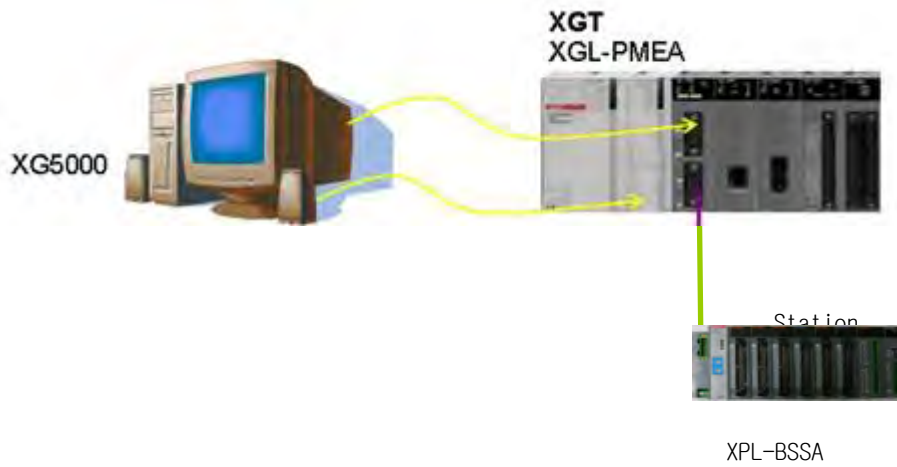

- System configuration



Slot location	1	2	3	4	5
Name	XBE-TN32A	XBE-RY16A	XBE-DC32A	XBF-AD04A	XBE-DV04A
Content	Tr out	Relay out	DC input	A/D conversion input module	D/A conversion output module
I/O data size	32 points (4 bytes)	16 points (2 bytes)	32 points (4 bytes)	64 points (8 bytes)	64 points (8 bytes)

[SYCON 1st step] Master and station no. setting

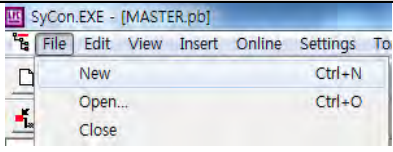
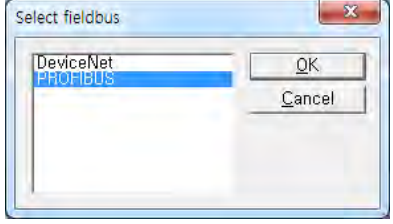
Menu setting: [File] – [New]

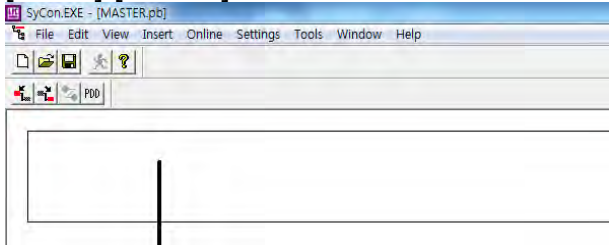
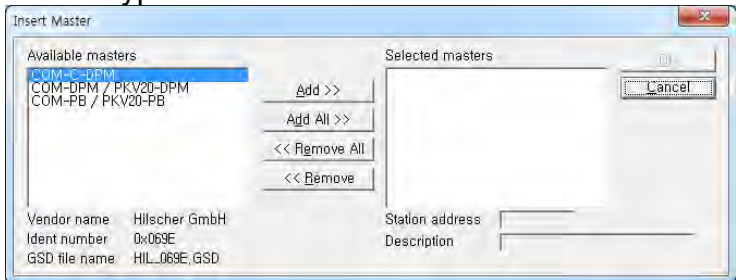
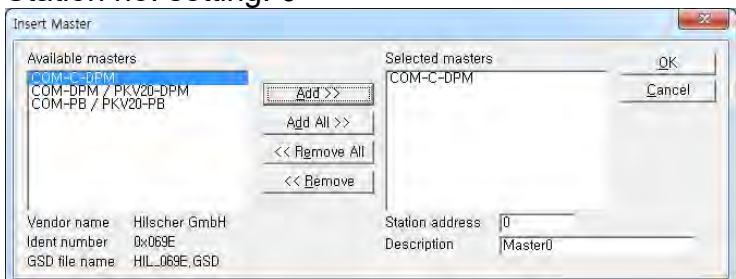
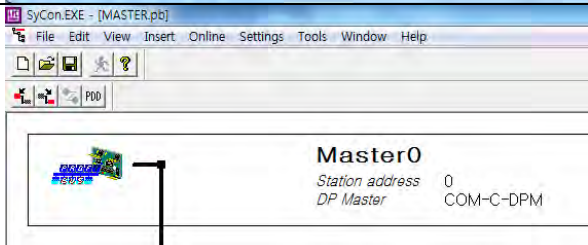
Step	Category	Screen formation and setting contents
1-1	Make a new file	 <p>New file writing</p>
1-2	Select PROFIBUS	 <p>PROFIBUS selection</p>
1-3	Master setting	<p>Recall master setting window</p> <p>[Insert]-[Master] or </p> 
1-4	Master insertion	<p>Master type selection: COM-C-DPM</p> 
1-5	Station no setting	<p>Station no. setting: 0</p> 
1-6	Master setting completion	 <p>Master0 Station address 0 DP Master COM-C-DPM</p>

[SYCON 2nd step] Setting of slave and station number

Menu selection: [Insert] – [Slave]

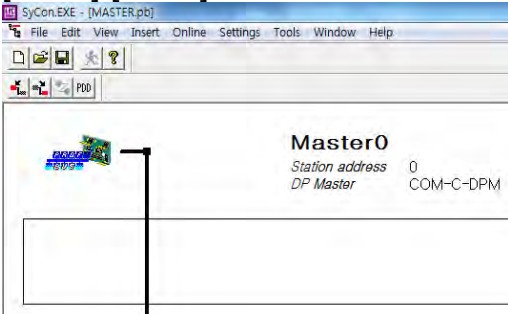
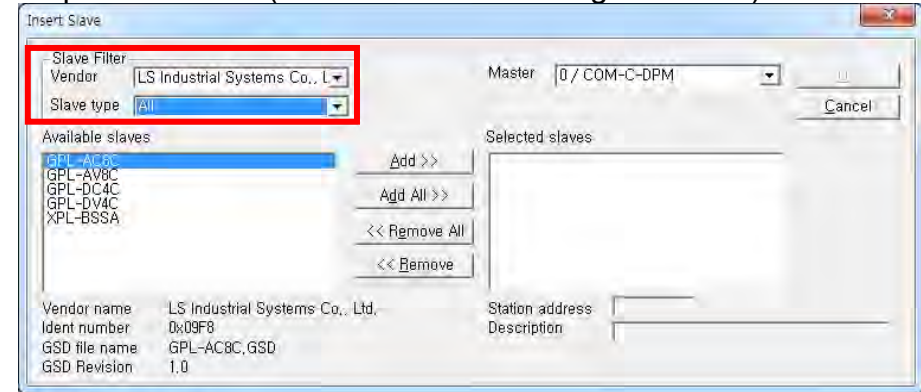
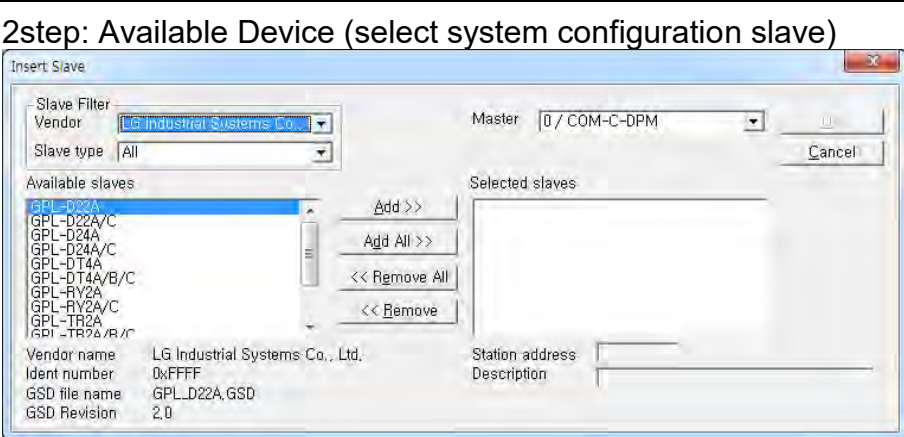
Step	Category	Screen formation and setting contents
2-1	Slave setting	<p>Recall master setting window. [Insert]-[Slave] or </p> 
2-2	Slave selection	<p>1step: Slave Filter (classification according to vendor)</p>  <p>2step: Available Device (select system configuration slave)</p> 

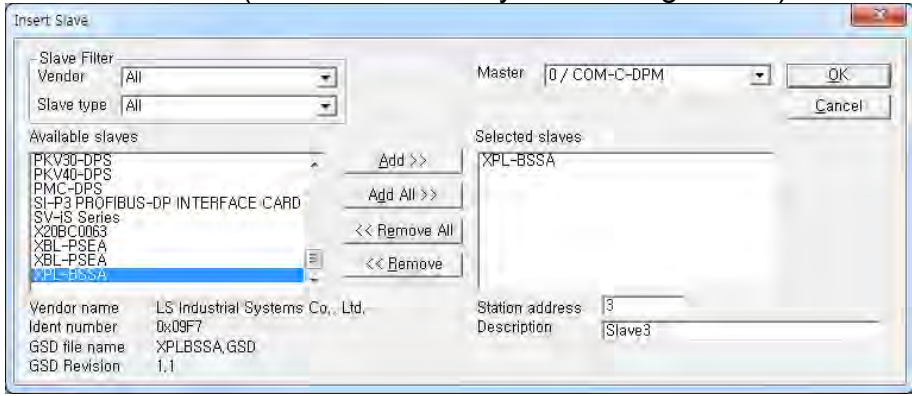
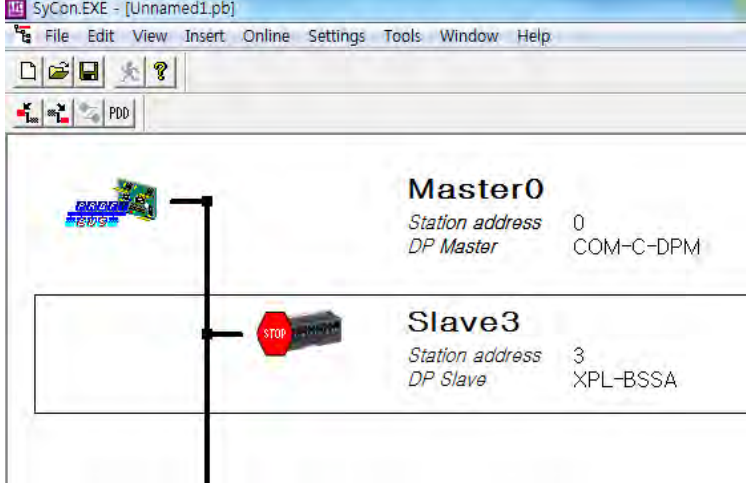
Step	Category	Screen configuration and setting contents
2-3	Station address setting	<p>Station Address (Set slave no. of system configuration)</p> 
2-4	Completion of slave setting	

[SYCON 3rd step] Set the method for slave communication – slave: XPL-BSSA
 Menu selection: Double click the slave

Step	Category	Screen configuration and setting content																																																																																					
3-1	Setting window for slave communication method	<p>Set slave</p>																																																																																					
3-2	Slave data structure	<p>Slave configuration setting: Add the module equipped at the XPL-BSSA in “Slot” consequently.</p> <table border="1"> <thead> <tr> <th>Module</th> <th>Inputs</th> <th>Outputs</th> <th>In/Out</th> <th>Identifier</th> </tr> </thead> <tbody> <tr> <td>Analog Output 4Channel</td> <td></td> <td>8 Byte</td> <td></td> <td>0x27</td> </tr> <tr> <td>Analog Input 4Channel</td> <td>8 Byte</td> <td></td> <td></td> <td>0x17</td> </tr> <tr> <td>Analog In/Out 2Channel</td> <td></td> <td></td> <td>4 Byte</td> <td>0x33</td> </tr> <tr> <td>Analog Input 8Channel</td> <td>16</td> <td></td> <td></td> <td>0x1F</td> </tr> </tbody> </table> <table border="1"> <thead> <tr> <th>Slot</th> <th>Idx</th> <th>Module</th> <th>Symbol</th> <th>Type</th> <th>I Addr.</th> <th>I Len.</th> <th>Type</th> <th>O Addr.</th> <th>O Len.</th> </tr> </thead> <tbody> <tr> <td>1</td> <td>1</td> <td>Digital Module1</td> <td></td> <td></td> <td></td> <td></td> <td>QB</td> <td>0</td> <td>4</td> </tr> <tr> <td>2</td> <td>1</td> <td>Digital Module2</td> <td></td> <td></td> <td></td> <td></td> <td>QB</td> <td>0</td> <td>2</td> </tr> <tr> <td>3</td> <td>1</td> <td>Digital Module3</td> <td>IB</td> <td></td> <td>0</td> <td>4</td> <td></td> <td></td> <td></td> </tr> <tr> <td>4</td> <td>1</td> <td>Analog Module4</td> <td>IB</td> <td></td> <td>0</td> <td>8</td> <td></td> <td></td> <td></td> </tr> <tr> <td>5</td> <td>1</td> <td>Analog Module5</td> <td></td> <td></td> <td></td> <td></td> <td>QB</td> <td>0</td> <td>8</td> </tr> </tbody> </table>	Module	Inputs	Outputs	In/Out	Identifier	Analog Output 4Channel		8 Byte		0x27	Analog Input 4Channel	8 Byte			0x17	Analog In/Out 2Channel			4 Byte	0x33	Analog Input 8Channel	16			0x1F	Slot	Idx	Module	Symbol	Type	I Addr.	I Len.	Type	O Addr.	O Len.	1	1	Digital Module1					QB	0	4	2	1	Digital Module2					QB	0	2	3	1	Digital Module3	IB		0	4				4	1	Analog Module4	IB		0	8				5	1	Analog Module5					QB	0	8
Module	Inputs	Outputs	In/Out	Identifier																																																																																			
Analog Output 4Channel		8 Byte		0x27																																																																																			
Analog Input 4Channel	8 Byte			0x17																																																																																			
Analog In/Out 2Channel			4 Byte	0x33																																																																																			
Analog Input 8Channel	16			0x1F																																																																																			
Slot	Idx	Module	Symbol	Type	I Addr.	I Len.	Type	O Addr.	O Len.																																																																														
1	1	Digital Module1					QB	0	4																																																																														
2	1	Digital Module2					QB	0	2																																																																														
3	1	Digital Module3	IB		0	4																																																																																	
4	1	Analog Module4	IB		0	8																																																																																	
5	1	Analog Module5					QB	0	8																																																																														

[SYCON 4th step] Serial port selection: It is same as RS-232C's wiring used in CPU module. So use that cable.

Menu selection: [Settings] – [Device Assignment]

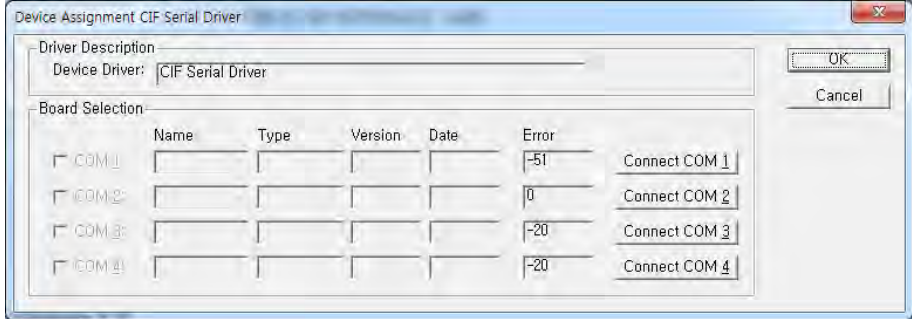
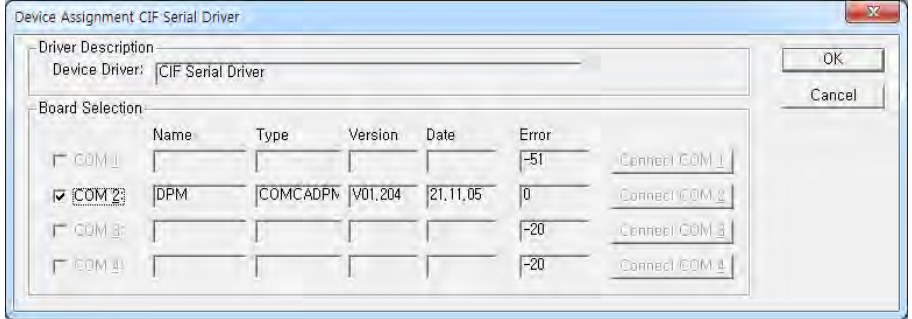
Step	Category	Screen configuration and setting contents
3-1	Setting window for serial port	<p>Serial port</p> 
3-2	Port research	<p>[Connect COM] In activated port among COM 1~4, error value is indicated as [0]</p>  <p>Marking activated port and select [OK]</p>

[SYCON 5th step] Download

Menu selection: [OnLine] – [Download]

[XG5000 1st step] Select type of CPU module

Menu selection: [Project] – [New Project]

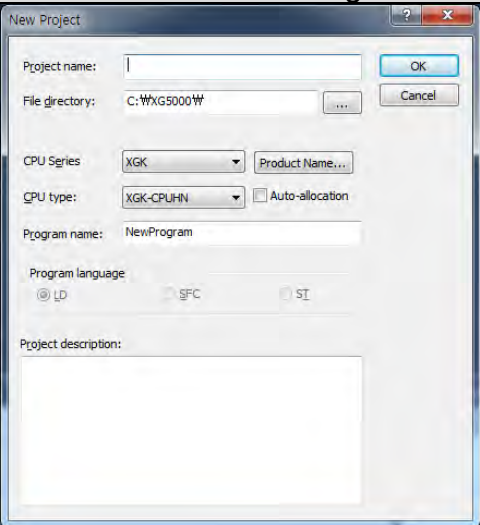
Step	Category	Screen configuration and setting contents
1-1	CPU module selection	

[XG5000 2nd step] Communication method setting

Menu selection: [Online] – [Connection setting]

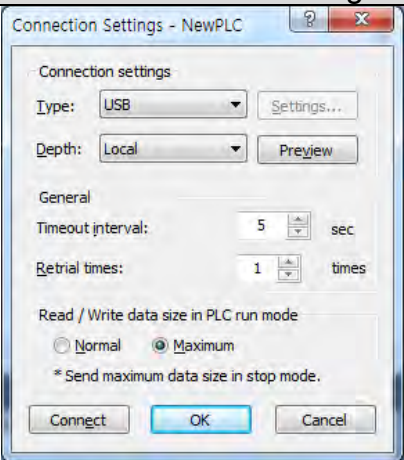
Step	Category	Screen configuration and Setting contents
2-1	Connection Settings	 <p>Connecting Type: USB Connecting Depth: local</p>

[XG5000 3rd step] Connection

Menu selection: [Online] – [Connection]

[XG5000 4th step] I/O information reading

Menu selection: [Online] – [Diagnosis] – [I/O Information] – [I/O Sync]

[XG5000 5th step] High-speed Link setting

Menu selection: Right click the XGL-PMEA module and select [Add Item] – [High-speed link communication]

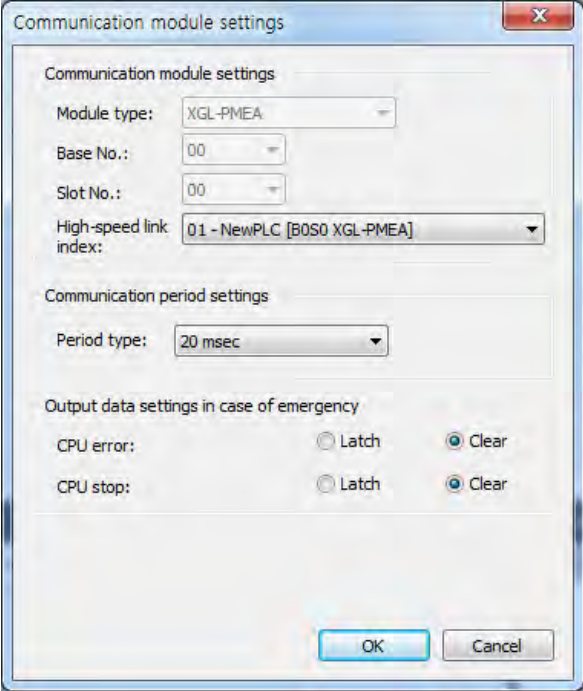
Step	Category	Screen configuration and setting contents
5-1	Communication module setting	<p>Initial screen</p> 

[XG5000 6-1st step] SYCON upload

Menu selection: [Online] – [SYCON upload (Pnet, Dnet)]

Step	Category	Screen configuration and setting contents
6-1	Communication module setting	Initial screen
		SYCON upload

[XG5000 6-2nd step] Read area / Save area setting

Menu selection: Double click the [High-speed link 01] in the project tree

Step	Category	Screen configuration and setting contents
6-2	Communication module setting	Initial screen
		High speed link block after set read/write area

Note

- Read area / Save area of slave extension module

Read area (Master → Slave)				Save area (Slave → Master)					
Device	Send data	Output module		Device	Receive data	Input module			
%MW1000	14bytes	4 bytes	TR out 32points	%MW200	12bytes	4 bytes	DC in 32points		
%MW1002		2 bytes	Relay out 16points	%MW202		2 bytes	A/Dconversion 4Channel	Ch 0	
%MW1003		2 bytes	D/A conversion 4Channel	Ch 0		%MW203		2 bytes	Ch 1
%MW1004		2 bytes		Ch 1		%MW204		2 bytes	Ch 2
%MW1005		2 bytes		Ch 2		%MW205		2 bytes	Ch 3
%MW1006		2 bytes		Ch 3					

[XG5000 7th step] Write High-speed link parameter

Menu selection: [Online] – [Write]

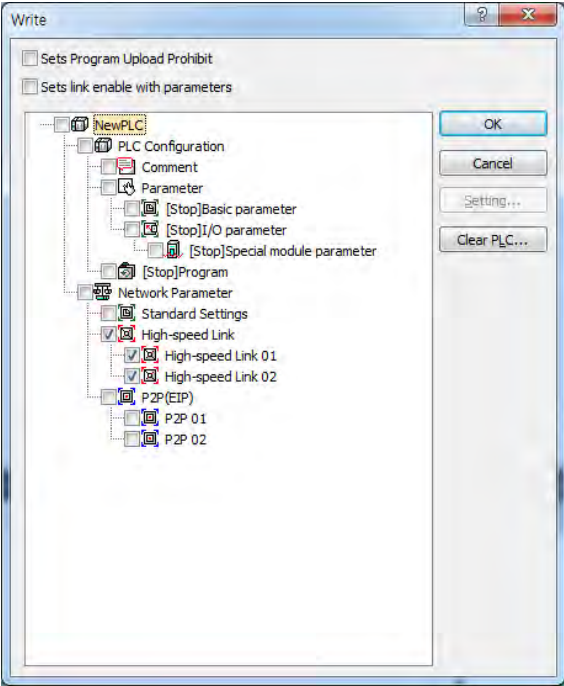
Step	Category	Screen configuration and setting contents
7-1	Write parameter	<p>Select High-speed link</p>  <p>- Press [OK], parameter is downloaded. - The data of parameter writing is stored in CPU module. So you should back-up High-speed link parameter when changing CPU module.</p>

[XG5000 8th step] Enable High-speed link

Menu selection: [Online] – [Communication module setting] – [Enable Link (HS link, P2P)]

Chapter 6 DeviceNet Communication

6.1 Overview

DeviceNet was born to meet the demand to replace the high-cost analog 4~20mA standard with simple digital standard and is the communication link to connect various kinds of industrial devices such as limit switch, photo electronic sensor, motor controller, inverter, barcode reader, panel display etc. to the network. The characteristics are low cost, simple installation, excellent compatibility with other maker's device as well as outstanding application in the network application such as Master/Slave, Multiple Master, and Peer-to-Peer etc. As DeviceNet uses CAN (Controller Area Network) protocol as it is and system response time is short, and the reliability is high, the production cost shall be low as we can use CAN chip with low cost.

DeviceNet Smart I/O module has the following characteristics.

- The real time control is available to communicate various I/O machines that are the lowest in the network system.
- One master module can control 63 slave module and max. 2,084 points I/O control is available.
- Network installation is flexible as multi drop and T branch connection is available.
- Available to connect the master module of LS ELECTIRC and various slave module of other maker.
- Available to configure the system with the slave module of LSIS and other maker's master module.
- Available to set station number (MAC Address) with hardware. (0 ~ 63 stations).
- The communication speed is set automatically according to the master setting.
- Available to install 2 master modules in GLOFA-GM4 and GM6.
- Available to equip 12 master modules in XGK/XGI.
- Available to communicate by *High-speed Link* parameter setting.
- Available to connect with various slaves I/O.
- Supports Poll, Cos, Cyclic, Strobe method as communication method.
- It is connection based communication, by using Explicit Messages, sends/receives real data through I/O message while connected with master.

It is used widely for general I/O, actuator, near-by switch, light switch, valve, inverter, A/D module, D/A module, position control, HSC, RTD etc.

6.2 Communication Specification

6.2.1 Frame Specification

Items		Performance Specification	
Transmission specification	Communication speed	125/250/500kbps	
	Communication distance (Thick) ^[*1]	500/250/100m	
	Max. drop length	125 kbps	6m(max. extension 156m)
		250 kbps	6m(max. extension 78m)
		500 kbps	6m(max. extension 39m)
	Data packet	0~8 Byte	
	Network structure	<ul style="list-style-type: none"> • Trunk/drop line • Power in the same network/signal cable 	
	Bus method ^[*2]	<ul style="list-style-type: none"> • Multi slave/ multi casting • Peer-to-Peer method • Poll, Strobe, COS/Cyclic method 	
	Max. node number	Max. 64 MAC ID/MAC Identifier	
	System type	Node insertion and removal in the status of voltage ON.	
	Action voltage	DC 24V (tolerance range: DC11~25V)	
Diagnosis function	The duplicate station check /bad station monitor /CRC error Check		

Remark

- 1) The transmission distance of Smart I/O module is in inverse proportion to data transmission ratio and when using Thin cable, the transmission distance is limited to 100m regardless of data transmission ratio.
- 2) For cable manufacturing and installation, please contact and discuss with the experts.

6.3 Communication Parameter Setting

DeviceNet should generally set the slave station that the master module will communicate with and set the station number, communication method, data size to communication, communication period necessary for the communication with the slave in order to enable to communicate. The files set as above are called "Scanlist file" with which the master module communicates with the slave module. Thus, after setting the Scanlist file such a service type, communication speed, station number etc. from *High-speed Link* parameter edit menu, Dnet I/F module begins to communicate by receiving all the setting Scanlist file from CPU.

In order to communicate with SMART I/O DeviceNet module, *High-speed Link* communication service is used. This function is used when changing the data and information of other station periodically at every specified time. By referring the changing data of the self-station or other station each other periodically, it enables to utilize the data to the system effectively and simply carry out the communication by setting the parameter.

The parameter setting method is to designate its self area and the area of other station to send or receive and data size, message type, station no. in GMWIN *High-speed Link* parameter and then carry out the communication. In XG-5000, it communicates by designating its self area and the area of other station by using XG5000.

Data size is available to communicate at least 1byte up to 256bytes (2,048 points) and the communication period is available to set min. 5ms up to 10sec. according to the communication contents. As it is available to communicate with other station by simple parameter setting, it is easy to use this program and the High-speed process of internal data enables to process lots of data at the same time periodically.

The following table shows *High-speed Link* point per communication model.

Max. Communication Point per model

Classification		Max. communication point	Max. block no.	Others
SMART I/O module	GDL-TR2A	16 points	64 (0-63)	Output module
	GDL-TR4A	32 points	64 (0-63)	Output module
	GDL-RY2A	16 points	64 (0-63)	Output module
	GDL-DT4A	32 points	64 (0-63)	Combined module
	GDL-D22A	16 points	64 (0-63)	Input module
	GDL-D24A	32 points	64 (0-63)	Input module
	XDL-BSSA	256 점	64 (0-63)	Adapter module

Remark

- 1) It is divided into A/B/C/C1 according to I/O characteristic, but communication point is same
- 2) For further information for master setting, please refer to the user's manual for DeviceNet.

6.3.1 High-speed link

High-speed link is High-speed communication service which receives and transmits data by setting the High-speed link parameter. The user can set the data size, transmitting/receiving area and storage area by using High-speed Link parameter.

(1) High-speed Link station setting function:

- (a) When there are various transmitting/receiving region, each receiving and transmitting can have max. 32 setting and total 64 setting.
- (b) The maximum setting Byte is 256 Byte per station.
- (c) The maximum link point is 2048 point.

(2) Transmitting/receiving region setting function:

According to the setting of I/O address, it is available to set the transmitting/receiving region for each station.

6.3.2 High-speed Link communication status flag information

(1) High Speed Link information function

High-speed Link flag information gives the user a method to check High-speed Link service status for reliability of data read from other station. Namely, there are TRX_STATE, DEVICE_MODE, DEVICE_ERROR's each information, which inform communication status according to each 64 register category in parameter.

The user uses it as a method for emergency or maintenance by combining the above information stored as a keyword type with High-speed Link transmitting/receiving data.

High-speed Link information

Classification	Transmitting/receiving status TRX_MODE	RUN mode DEV_MODE	Error DEV_ERROR
Type of information	Each information	Each information	Each information
Key Word Name (□=High-speed Link Number 1,2,3,4)	<code>_HS□TRX[n]</code> (n=each parameter 0~63)	<code>_HS□MOD[n]</code> (n= each parameter 0~63)	<code>_HS□ERR[n]</code> (n= each parameter 0~63)
Data Type	BIT-ARRAY	BIT-ARRAY	BIT-ARRAY
Monitoring	Available	Available	Available
Use of Program	Available	Available	Available

(a) Transmitting/receiving status ($_HS□TRX[0..63]$)

If each parameter operation set in each parameter registration number (0~63) operates according to transmitting/receiving period, each bit is On, otherwise Off.

(b) RUN mode ($_HS□MOD[0..63]$)

It indicates the mode information of parameter operation set in each parameter registration number (0~63). If the station set in registration is RUN mode, each bit is On. If STOP/PAUSE/DEBUG mode, then Off

(c) Error ($_HS□ERR[0..63]$)

It indicates the parameter error information set in each parameter registration number (0~63). The error signal means that the PLC can't execute the user program properly.

When Off, other station is not under normal operation.

When On, other station is under normal operation.

Remark

Keyword contents used in category (a) ~ (c)

□: Indicates the High-speed Link number (1, 2, 3, and 4) used in setting parameter.

(Generally, if the number of communication module equipped is 1, we use the High-speed Link 1)

[0..63]: indicates the registration number of each parameter in the left figure of [Figure 6.2.2(E)]

(Checks the communication status according to each parameter in 0~63's each registration number

6.3.3 High-speed Link information monitor (GMWIN)

After connecting the GMWIN online, we can monitor by using the monitor function. We have two methods for monitoring. (Variable Monitor and Parameter Monitor)

(1) Variable Monitor

By using the Variable Monitor, we can monitor the necessary category.

The sequence is as follows

- (a) Select the Variable Monitor in the Monitor category of online.
- (b) Select the Flag in the variable registration screen.
- (c) Select the High-speed Link information flag which you want to monitor in the variable, flag list screen and register. (`_HSxERR[n]`, `_HSxMOD[n]`, `_HSxTRX[n]` is ARRAY flag so you should input the registration number that you want to monitor in the parameter directly).

※ 'x' indicates High-speed Link No., [n] indicates the each parameter No.(0~63)

Resou...	Instance	Variable name	Variab...
Flag		._HS1ERR[1]	0
Flag		._HS1ERR[2]	0
Flag		._HS1ERR[3]	0
Flag		._HS1ERR[4]	0
Flag		._HS1ERR[5]	0
Flag		._HS1ERR[6]	0
Flag		._HS1ERR[7]	0
Flag		._HS1ERR[8]	0
Flag		._HS1TRX[1]	0
Flag		._HS1TRX[2]	0
Flag		._HS1TRX[3]	0
Flag		._HS1TRX[4]	0
Flag		._HS1TRX[5]	0
Flag		._HS1TRX[6]	0
Flag		._HS1TRX[7]	0
Flag		._HS1TRX[8]	0
Flag		._HS1MOD[1]	0
Flag		._HS1MOD[2]	0
Flag		._HS1MOD[3]	0
Flag		._HS1MOD[4]	0
Flag		._HS1MOD[5]	0
Flag		._HS1MOD[6]	0
Flag		._HS1MOD[7]	0
Flag		._HS1MOD[8]	0

Registration screen of High-speed Link information variable

(2) Link parameter monitor

You can monitor the communication status in the parameter category directly by using this function. If you select the parameter window category in the [View] menu of the GMWIN online connection, the parameter monitor screen opens and registration list set in the above shows.

In the link parameter monitor, each information about mode (run mode), communication (transmitting/receiving status) and error is indicated according to the parameter category.

Run_Link: 0 Link_Trouble: 0 HS Link 1

No	Type	Class	From Area	To Area	S Mode	Trx	Error
0					0	0	0
1					0	0	0
2					0	0	0
3					0	0	0
4					0	0	0
5					0	0	0
6					0	0	0
7					0	0	0
8					0	0	0
9					0	0	0
10					0	0	0
11					0	0	0
12					0	0	0
13					0	0	0
14					0	0	0
15					0	0	0

Example of High-speed Link monitor screen (example)

The meaning of value monitored above figure is as follows.

- **Mode 1:** It indicates that station address (6 stations) set at each parameter is RUN mode
It is '0' when mode is STOP/PAUSE/DEBUG
- **Communication 1:** As contents set in parameter registration address, it executes proper communication and express minus.
- **Error 0:** As contents set in parameter registration address, it indicates that error does not occur during communication.

6.3.4 High-speed Link Service (GMWIN)

SMART I/O Dnet module sets its self station no. to communicate with the master module by using the rotary switch and the communication speed is set automatically according to the master module setting. To control the single type remote module, it is available to communicate only by *High-speed Link* parameter setting in GMWIN and easy to interface with the module of LSIS and other maker's.

The following table shows the basic configuration of the single type remote module.

Specification of single type remote module

Module name		Contents		Service mode
GLOFA-GM	GDL-TR2A	TR output 16 points		Poll, Strobe, COS/Cyclic service
	GDL-TR4A	TR output 32 points		
	GDL-DT2A	DC/TR combined 16 points		
	GDL-D22A	DC input 16 points		
	GDL-D24A	DC input 32 points		
	GDL-RY2A	Relay output 16 points		
Other maker's example	OMRON	DRT1-OD08	TR output 8 points	Poll service
	A.B	1794-OB16	TR output 16 points	Poll service
		1794-IB16	DC 24V input 16 points	

ScanList is the communication information data that the user must set so that the master module carries out the predefined communication with the slave module when the power ON. Thus, the user is required to set the information for the slave module to communicate with Dnet I/F module by using *High-speed Link* parameter.

The following is the setting method for High-speed Link parameter.

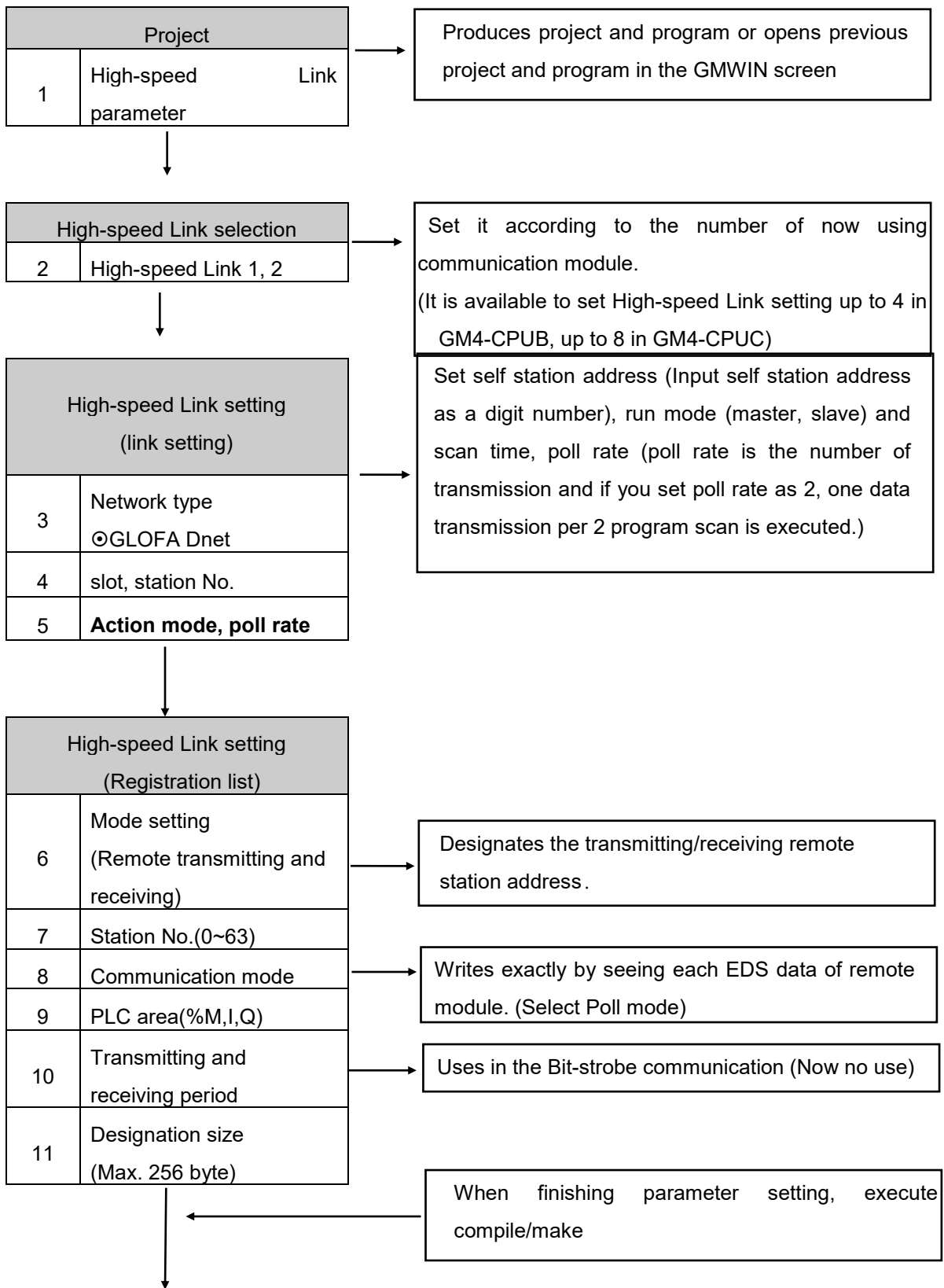

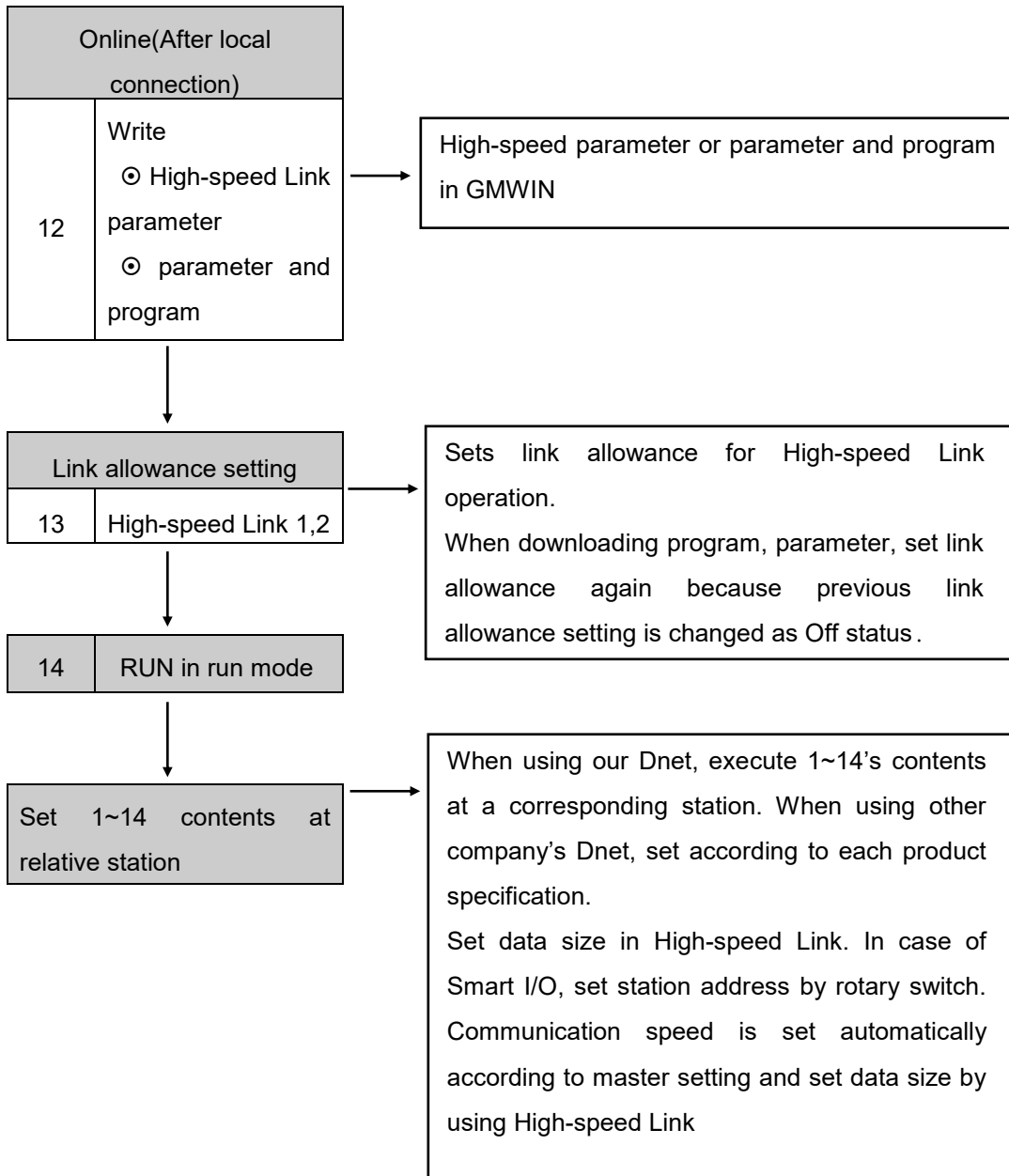

* In case of GM4-CPUB, it is available to set High-speed Link 1,2,3,4

* In case of GM4-CPUC, it is available to set High-speed Link 1,2,3,4,5,6,7,8

The following describes the method to set the Scan list by using *High-speed Link* parameter for Dnet communication.

First, select the project file which is suitable for CPU type by using GMWIN and then select *High-speed Link* parameter from the project file and finally select 'High-speed link 1'.

High-speed Link parameter selection screen

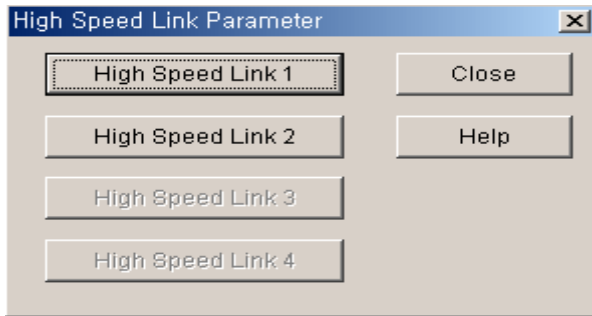

After selecting 'High-speed link 1', select '<->' mark from the below figure to set the slot position that Dnet I/F module is installed, station no, action mode and scan time and poll rate.

You can see the following screen by click 'High Speed Link 1'

Parameter setting initial screen

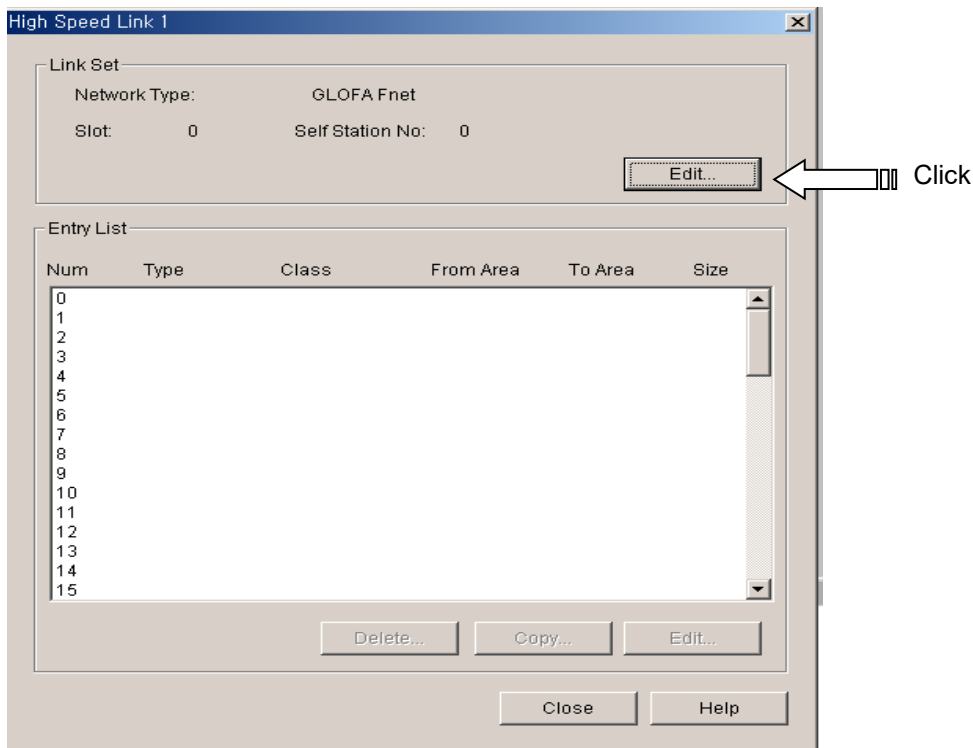

The following figure shows when you press 'Edit' button. Network type, Slot Num, Scan Time, Sele-station number and Pollate can be set

High-speed Link 1 set screen

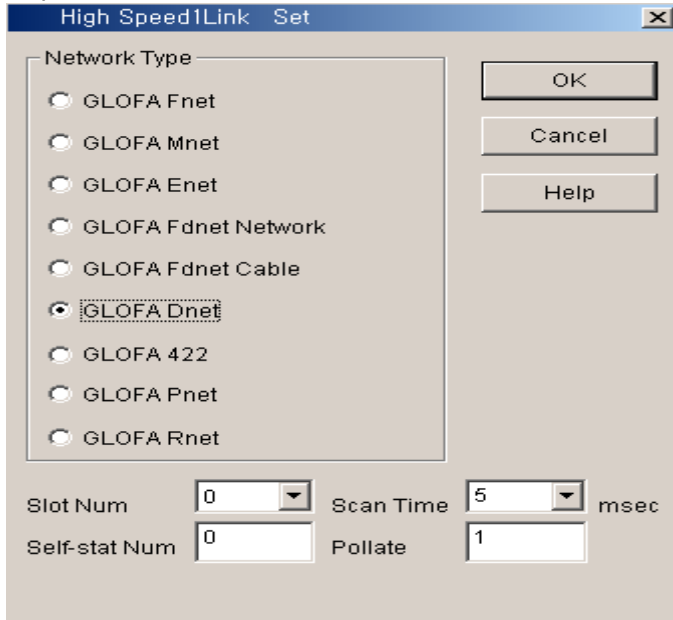

When setting the network type, slot no., self-station number, delay scan time, poll rate etc, the registration list no.'0' shall be set automatically in the self-station and for the registration list no.1~63, the module that the user wants to communicate shall be set.

The following screen shows when you click 'entry list 1'. Output slave module's information is registered.

Mode and Communication area setting screen (GDL-TR2A/B/C1/C)

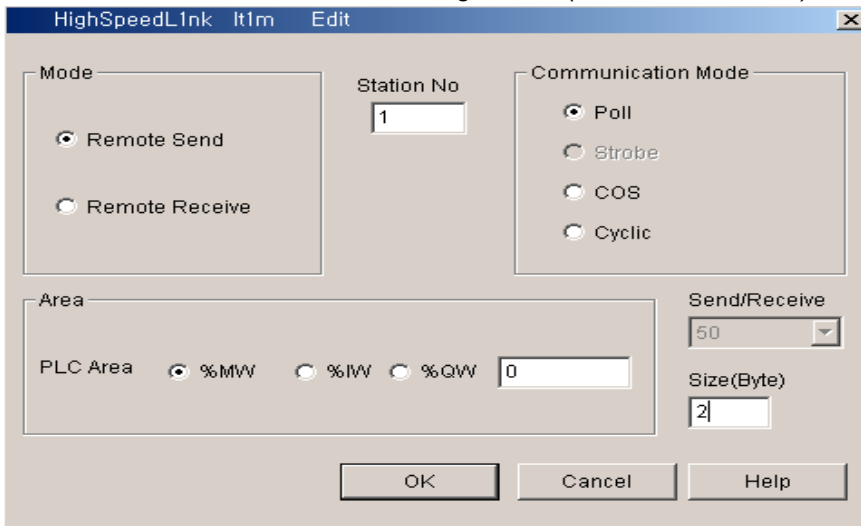

The following describes the sending data setting method of smart I/O output module. From the parameter menu, you set module's type (Input or output) in the 'mode', slave module's station address in the 'station addresses', and set as Poll which is communication method of slave module in the 'communication mode', set self data area to send in the 'area', set output module's data size as 2 byte in the 'size'. Slave module don't have parameter to set, according to communication speed, it is controlled by master module.

Link setting description

Classification	Description
Network type	This is to set the communication module type by 'GLOFA Dnet'
Slot no.	For the slot no. that the desired communication module to set is installed, select one from the range 0~7. (The right side of CPU module is '0' slot.)
Self station no.	Enter the self-station no. that is set in the station number switch of communication module front side. It is available to set 0~63 by decimal number but it is not allowed to use duplicate station no. as the self station no. is the unique number to distinguish communication module in the same network system.
Scan time	This is the scan delay time (msec) to delay to next scan after Dnet I/F module scanned the slave module all.
Poll rate	This is the rate that Dnet I/F module scans the slave module. That is, if the value is '2', this means that after scanning Dnet I/F module twice, one time 'poll' shall be executed for the module of station number set in the parameter.

In order to communicate with output module (GDLTR2A(B/C/C1)/RY2A(B/C/C1)/TR4A(B/C/C1)) among Dnet remote module, it is required to set the sending only. The receiving setting is not required.

High-speed Link parameter setting description (master module setting)

Classification		Description
Mode	Remote sending	Sends the data to SMART I/O output module.
	Remote receiving	Receives the data from SMART I/O input module.
Station no.		Designates the station no. of single type I/F module to communicate.
Communication mode	Poll	Performs Poll service.
	Strobe	Performs Strobe service.
	COS	Performs COS service.
	Cyclic	Performs Cyclic service.
Area	In case of Remote sending mode	Designates the sending data area of the self-station to send to the SMART I/O output module.
	In case of Remote receiving mode	Designates the area of the self-station to save the data received from SMART I/O input module. (%IW area Disable)
Sending/receiving period (msec)		Sets the sending/receiving period of the data.
Size (byte)		Sets the data size to send/receive and in case of communication between self-station, the unit is 2bytes and in case of communication with other makers, the data size shall be set as the byte that the corresponding module requires.

In order to communicate with input module among SMART I/O DeviceNet module, it is required to set the parameter related with receiving only (one of the entry list) as shown on the figure. The sending setting is not required.

Mode and Communication area setting screen (GDL-D22A)

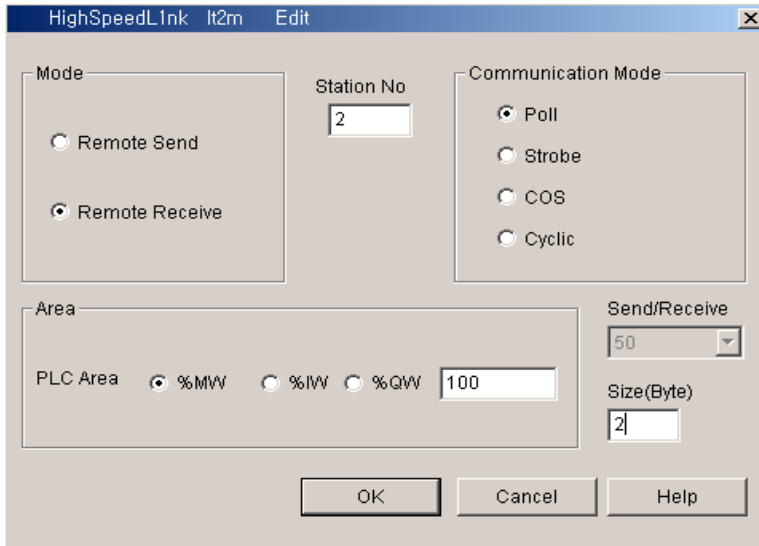

The following shows the setting to communicate with station 1,2 using Poll service.

High-speed Link parameter sending/receiving setting

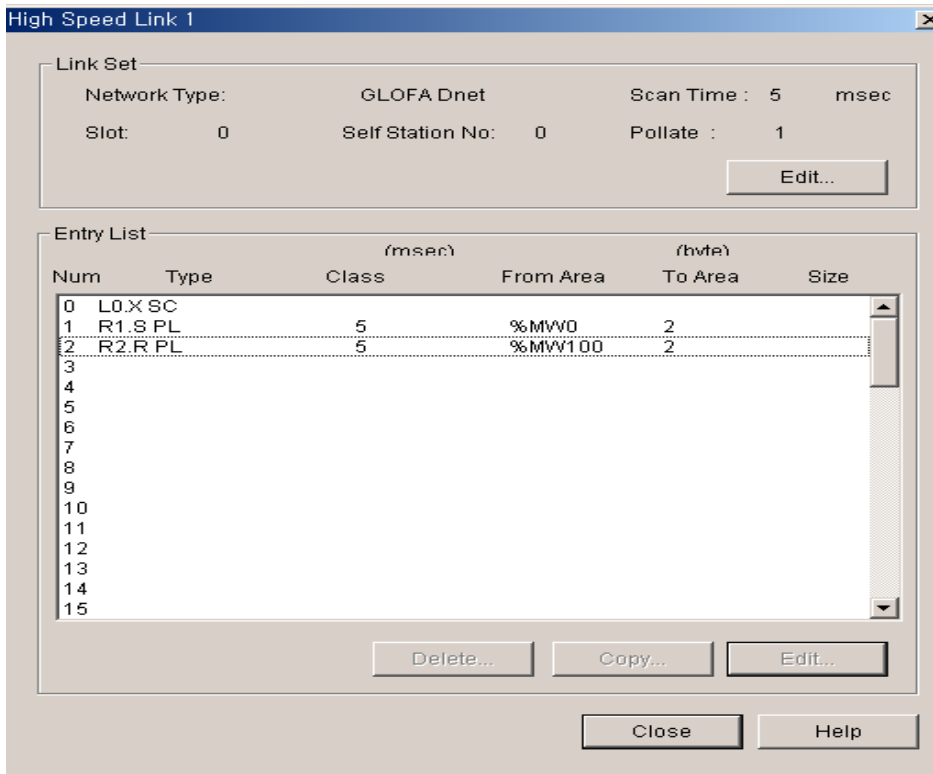

Remark

- 1) When communicating with the single type I/F module of other maker, the setting method is the same as GLOFA-GM series and only data size shall be set as follows.
 - ↳ DRT1-OD08 : 1 byte
 - ↳ 1794-OB16/IB16 : 4 bytes

- 2) When setting *High-speed Link* in the master (G4/6L-DUEA), in case of the combined module (GDL-DT4A), it is not available to connect if setting only with input. If setting only with output or the combined, the connection shall be done normally.

The meaning of Poll service setting

Scan type	Sending period	PLC area	Size	Description
R1.S PL	5×1 = 5msec	%MW0	2	Sends 2 byte data in %MW0 to the station 1 every 5msec by using Poll Request.
R2.R PL	-	%MW100	2	Saves 2 byte received by station 1 using Poll Response in %MW100.

* Here the sending period is Scan time × Poll rate.

Program Write

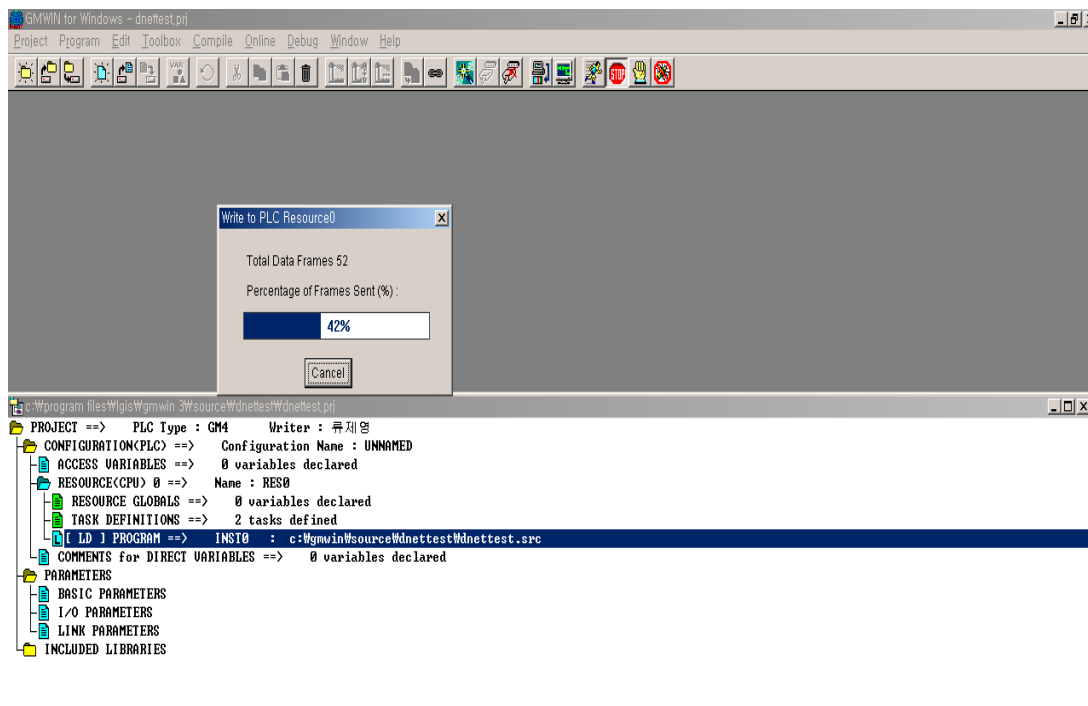

As shown above, in order to communicate with Dnet master module and Smart I/O module, the user should check the slave information correctly and then set *High-speed Link* parameter. Thus, after setting *High-speed Link* parameter correctly, the user can download it through the online connection of GMWIN.

High-speed Link Enable link

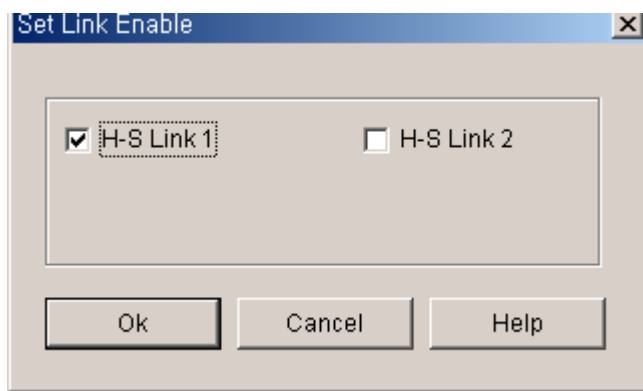

If program download is completed, Enable the 'link enable' setting in the online menu. If Enable is confirmed, change the CPU program mode with RUN. If the mode is changed with RUN, the data sharing begins immediately and the communication starts.

6.3.5 High-speed Link information monitor (KGLWIN)

We can monitor High-speed Link information by using monitoring window and [Read Info.] menu after connecting the KGLWIN online. We have the following two methods for monitoring

(1) Flag monitor

We can monitor necessary monitor which we want to check by using flag monitor menu of KGLWIN. First, if select flag monitor button in the monitoring window, the lower flag monitor screen shows. And pressing (▼) button, the flag registration screen shows. Select High-speed Link information flag and register it in flag registration screen. For flag information, refer to the Appendix's flag list. If monitor does not operate, check whether monitor mode is START MODE or not.

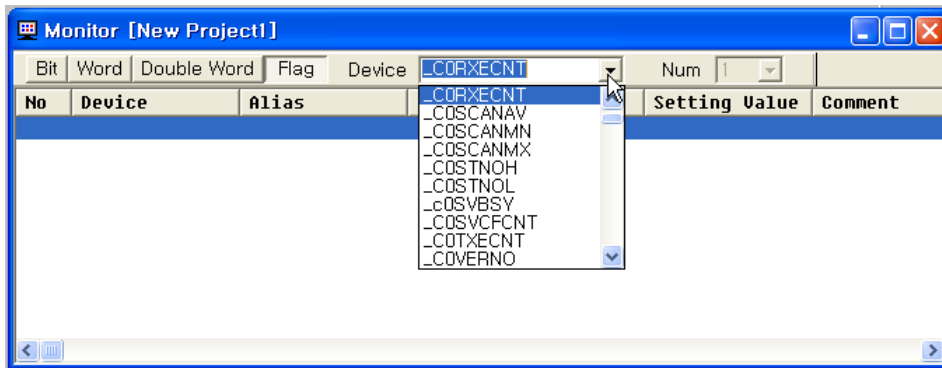

Flag monitor screen and flag registration screen.

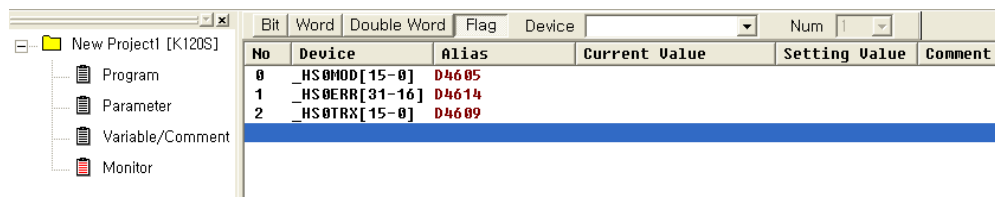

Flag monitor screen (flag is registered)

(2) High-speed Link parameter monitor in information reading

If you select High-speed Link parameter in Menu Online-Info., we can see specific information about High-speed Link parameter as follows

High-speed Link parameter monitor

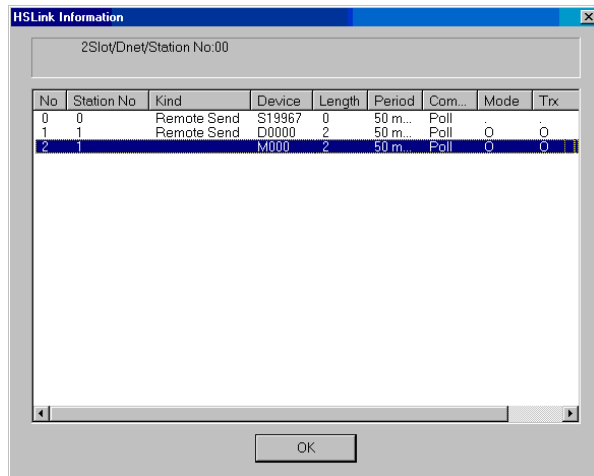

(3) Link information monitor in Read Info.

If selecting Menu Online-Read Info. - Link Info., you can monitor link status of communication module equipped according to the slot.

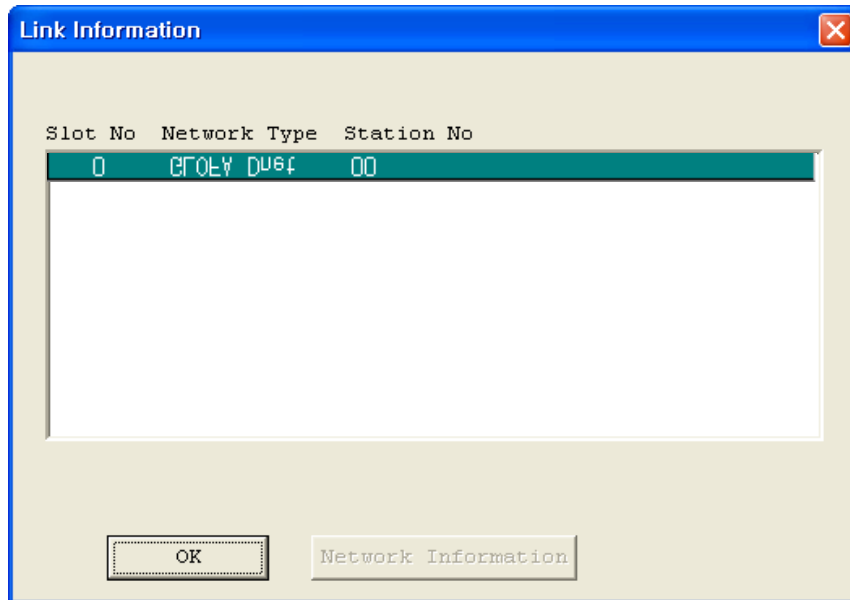

6.3.6 Sequence of High-speed Link setting (KGLWIN)

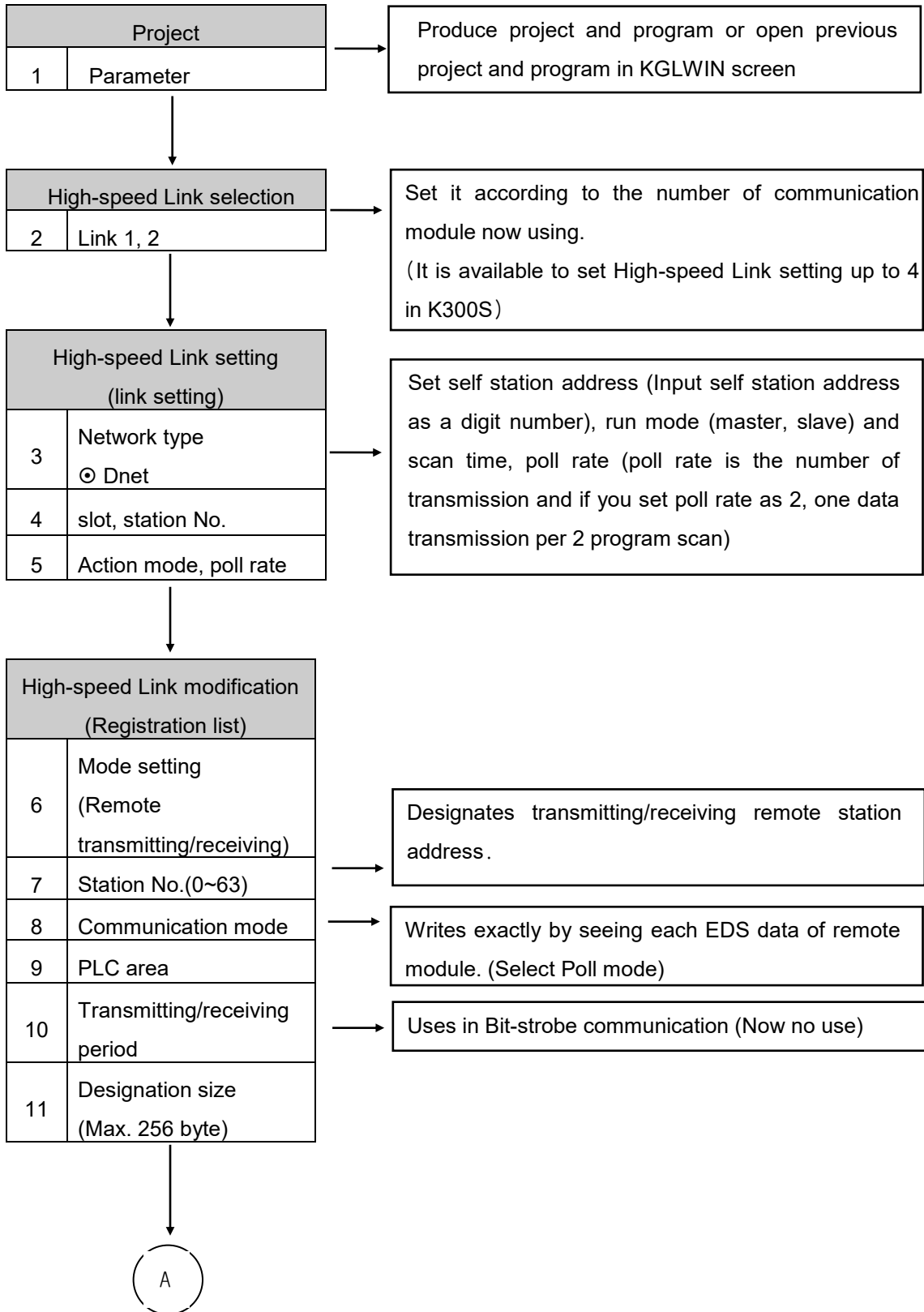

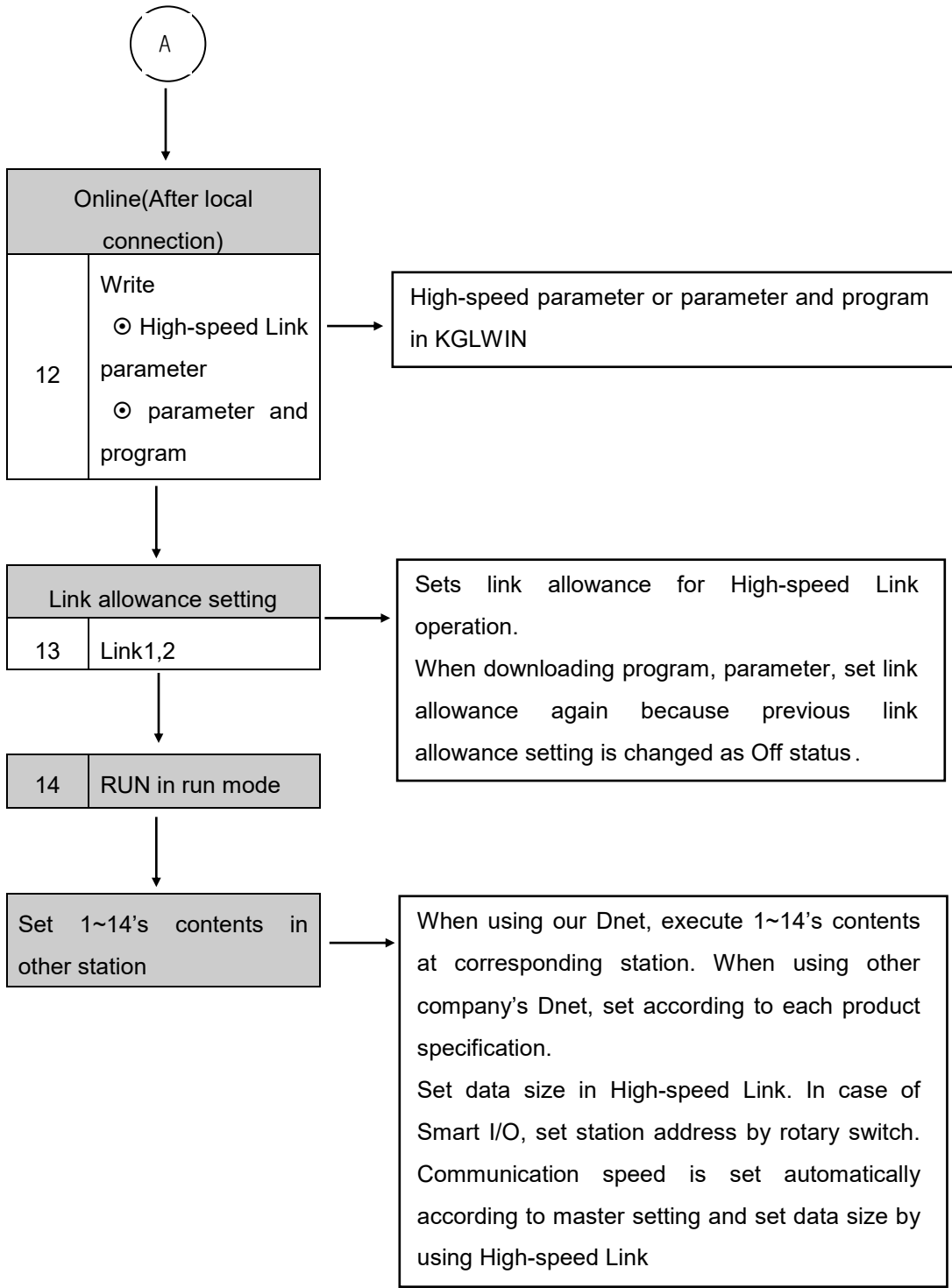

6.3.7 High-speed Link operation (KGLWIN)

After finishing parameter setting pressing [OK] button, if you execute parameter download, High-speed Link service starts. When doing this, each link should be allowance status. Next figure is screen downloading the parameter, if you select menu-online-download, the following figure shows

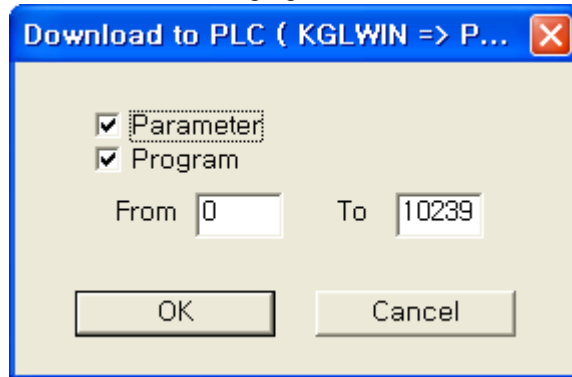

Parameter downing loading screen

High-speed Link downloading is available when PLC mode is PLC STOP mode. And if you start by High-speed Link allowance, it executes High-speed Link regardless of the PLC mode. Parameter and Link allowance information is reserved when POWER is off by battery back up. The following table explains PLC mode's relation with High-speed Link operation

PLC mode's relation with High-speed Link operation

Mode	Parameter download	High-speed Link operation	Reference
RUN	X	O	High-speed Link operates regardless of PLC mode when High-speed Link allowance
STOP	O	O	
PAUSE	X	O	
DEBUG	X	O	

6.3.8 Sequence of High-speed Link setting (XG5000)

Set the XG5000 After setting the SyCon.

If SyCon is not set properly, you can't communication.

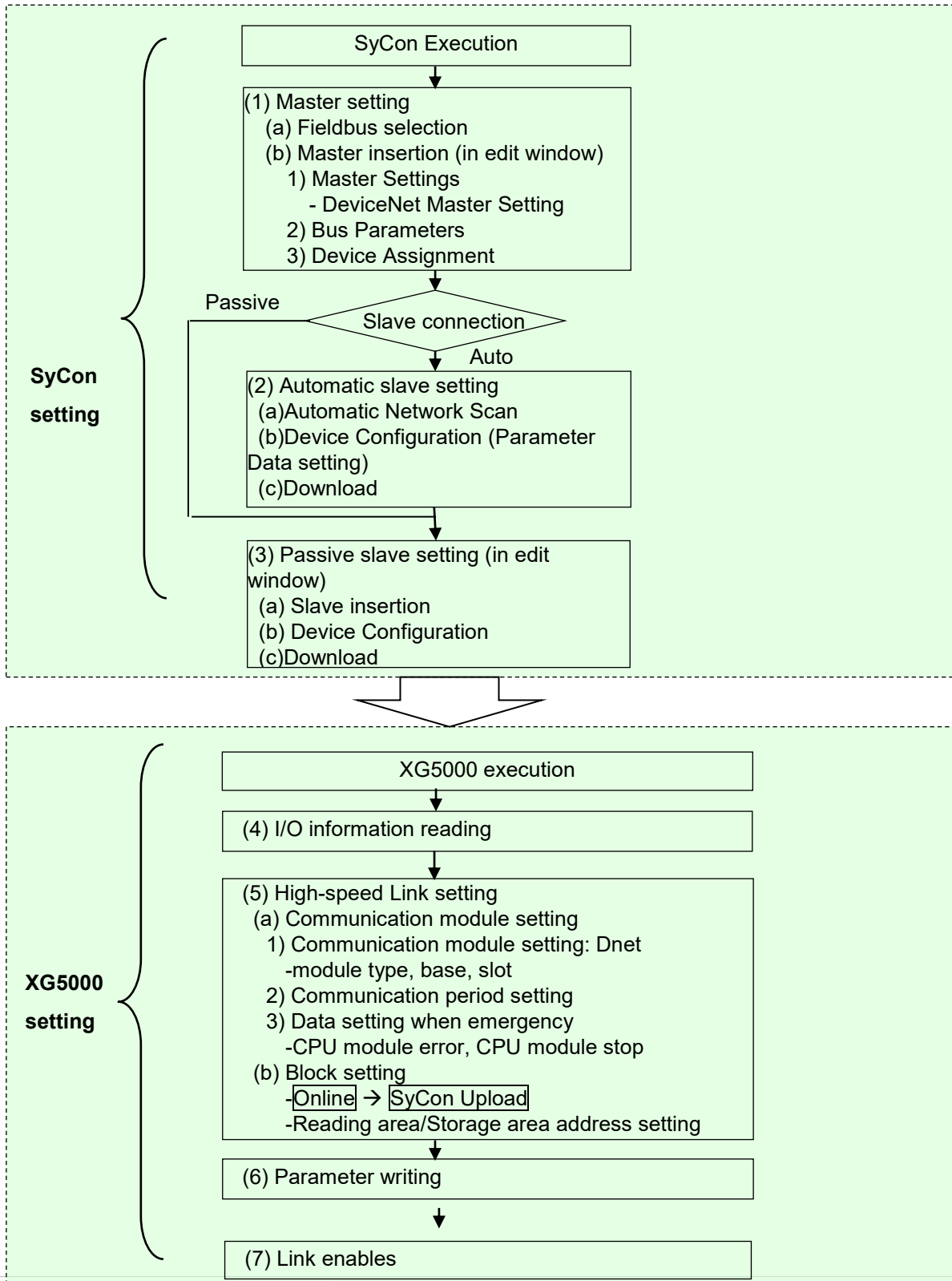

(1) SyCon execution

Sets basic parameter about Dnet communication between master and slave.

In order to configure master and slave, it has two method as follows.

(a) configuration by EDS file

Merit: setting early about actually unconnected slave

Demerit: if it is not set correctly, communication is not conducted.

(b) Auto Scan method

Merit: speed is fast and able to set parameter fast.

Demerit: it is limited to slave actually connected to network

Therefore, you should choose proper method according to user needs

1) Initial screen execution

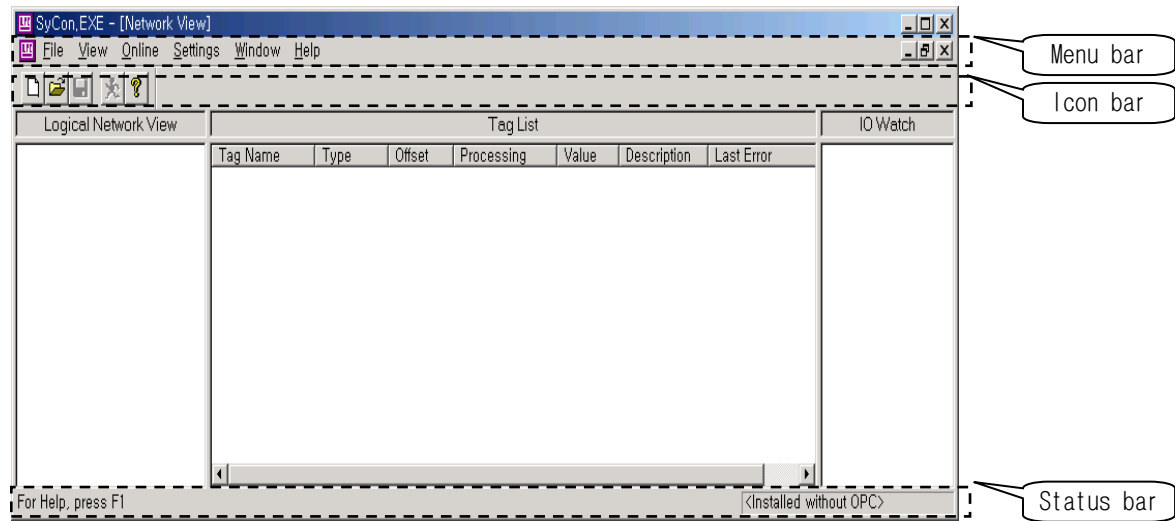

[Network screen]

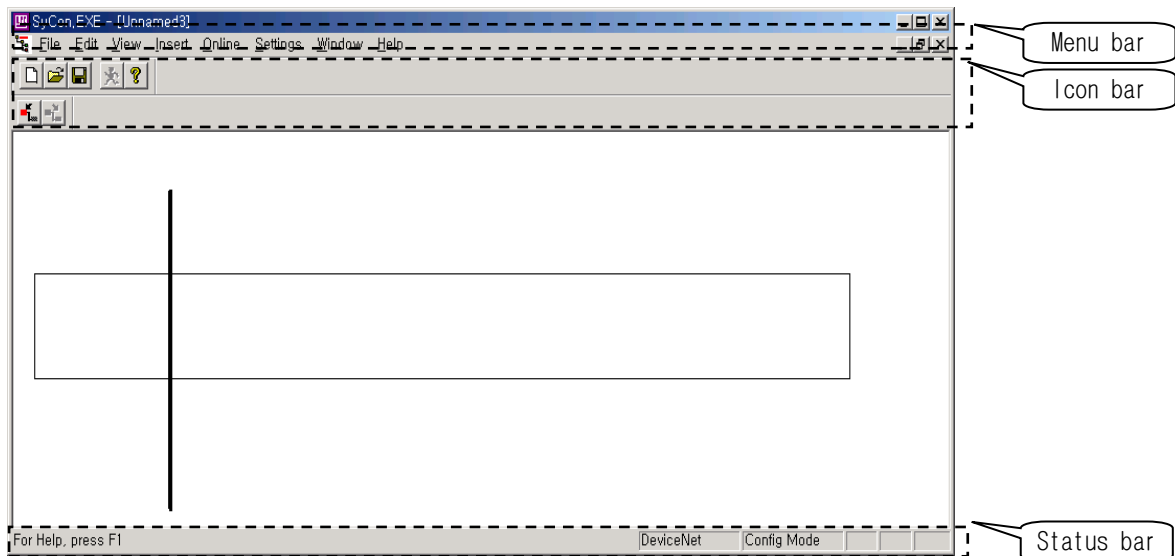

[Edit screen]

2) Configuration menu

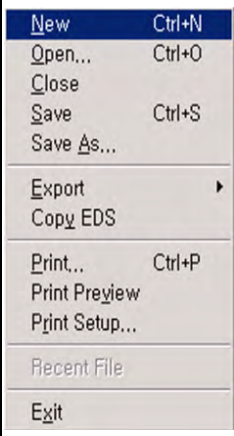
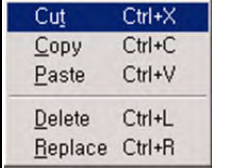
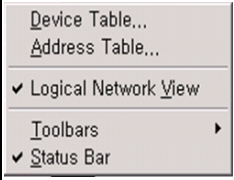
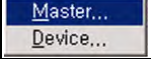
Main menu	Sun menu	Description	reference		
File		New	Make new files	M/S	
		Open	When opening the previous files	M/S	
		Close	When closing the activated files	M/S	
		Save	When saving the activated files	M/S	
		Save As	When saving the activated files as another name	M/S	
		Export	When sending the project files	M/S	
		Copy	DBM	When opening the file of DBM extension	M/S
			CSV	When opening the file of CSV extension	M/S
		Print...	Print	M/S	
		Print Preview	Preview print	M/S	
		Print Setup...	Setting the print	M/S	
		Recent File	Indicates the recent files.	M/S	
		Exit	When exiting the SyCon	M/S	
		Editor		Cut	Cut
Copy	Copy			S	
Paste	Paste			S	
Delete	Delete			S	
Replace	Replace			M/S	
Device Table	Indicates Network setting status(MAC ID,Master/Slave) as Table form			M/S	
View		Address Table	Shows address of slave module and I/O size.	M/S	
		Logical Network View	Convert as initial screen's Logical View in the edit screen.	M/S	
		Toolbars	Standard	When activating the basic menu bar.	M/S
			Fields	When activating the Insert Icon menu bar	M/S
		Status Bar	When indicates Status Bar in the SyCon basic window.	M/S	
		Insert		Master	When inserting the master module
Device	When inserting the slave module			M/S	

* M in the reference category: It means master and it is sub-menu activated when selecting the master in the edit window.

S: It means slave and it is sub-menu activated when selecting the slave in the edit window.

Main menu	Sub-menu	Description	Reference	
Online	Download	When downloading the SyCon setting file	M	
	Start Debug Mode	When seeing the present connection status	M	
	Download... Ctrl+D	Device Diagnostic	When seeing the saved diagnosis information	M
	Start Debug Mode	Firmware Download	When downloading as Firmware	M
	Device Diagnostic...	Firmware/Reset	When resetting Firmware	M
	Firmware Download...	Extended Device Diagnostic	Device's extended diagnosis	M
	Firmware / Reset...	Global State Field	When seeing the present status of communication and module	M
	Extended Device Diagnostic...	Live List	When seeing information and status according to station address	M
	Global State Field...	I/O Monitor	Shows I/O data	M
	Live List...	Message Monitor	Analysis data between master and slave	M
	I/O Monitor...	Automatic Network Scan	When setting the network automatically	M
	Message Monitor...	Get Device Attribute/ Set Device Attribute	When changing the slave characteristic value	S
	Automatic Network Scan...	Start Communication	When operating the communication	M
	Get Device Attribute / Set Device Attribute...	Stop Communication	When stopping the communication	M
	Start Communication...	Device Info	Indicates Device's manufactured data, serial number	M
	Stop Communication...	Activate Driver	When selecting the connection driver with PC	M
	Device Info...	Read project Information	Indicates project information	M
	Activate Driver...			
Read Project Information...				
Settings	Device Assignment... Ctrl+B	Device Assignment	Sets method to communicate with Host	M
	Bus Parameters...	Bus Parameters	When setting communication speed and parameter	M
	Master Settings...	Master Settings	Master module's setting	M
	Device Settings...	Device Settings	-	-
	Device Configuration...	Device Configuration	When setting slave parameter	S
	Auto Addressing	Auto Addressing	When allocating the address automatically	M/S
	Project Information...	Project Information	Sows project's information	M/S
	Path...	Path	Route of EDS setting file and project file	M/S
	Language...	Language	Language selection	M/S
Window	Cascade	Cascade	When setting window array as cascade	M/S
	Tile	Tile	When setting window array as tile	M/S
Help	1 Network View			
	2 Unnamed2			
	Help Topics...	Help Topics	Seeing HELP	M/S
	About...	About	SyCon program information	M/S

* M in the reference category: It means master and it is sub-menu activated when selecting the master in the edit window.

S: It means slave and it is sub-menu activated when selecting the slave in the edit window.

3) Make New File

You can auto-set slave through Aut0scan if you set master through 'make new file'.

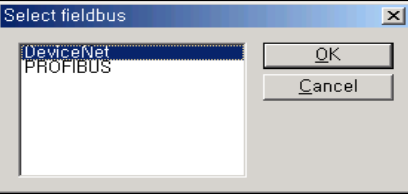
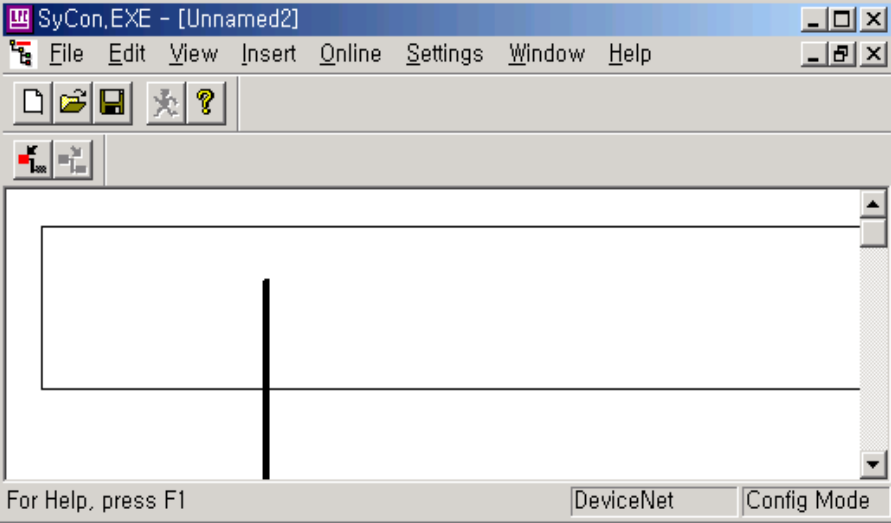
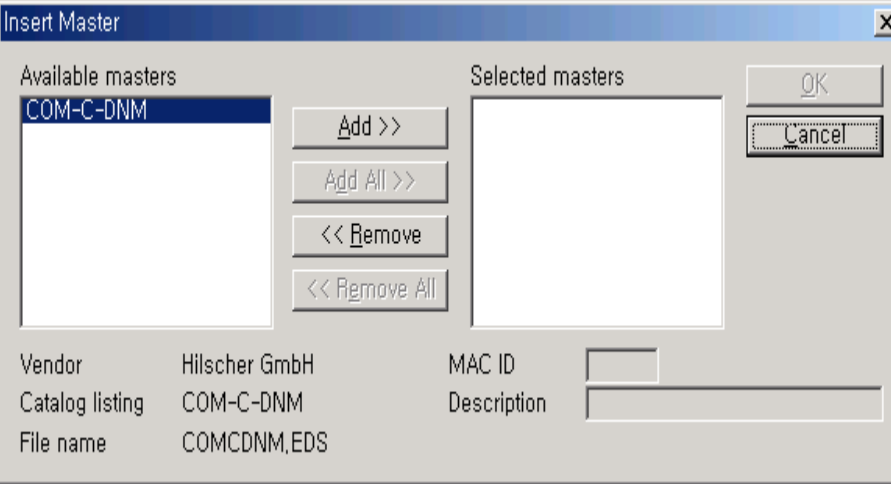
Classification	Composition screen								
Fieldbus selection									
Screen configuration									
Master selection	 <table border="1" data-bbox="393 1703 949 1805"> <thead> <tr> <th colspan="2">Master type</th> <th>EDS File name</th> <th>Master name</th> </tr> </thead> <tbody> <tr> <td>XGT</td> <td>XGL-DMEA</td> <td>COMCDNM</td> <td>COM-C-DNM</td> </tr> </tbody> </table>	Master type		EDS File name	Master name	XGT	XGL-DMEA	COMCDNM	COM-C-DNM
Master type		EDS File name	Master name						
XGT	XGL-DMEA	COMCDNM	COM-C-DNM						

4) Master/slave selection

a) Master

(1) Selection

Method	Selection sequence
Method by menu bar	Insert → Master
Method by icon	

(2) Insert

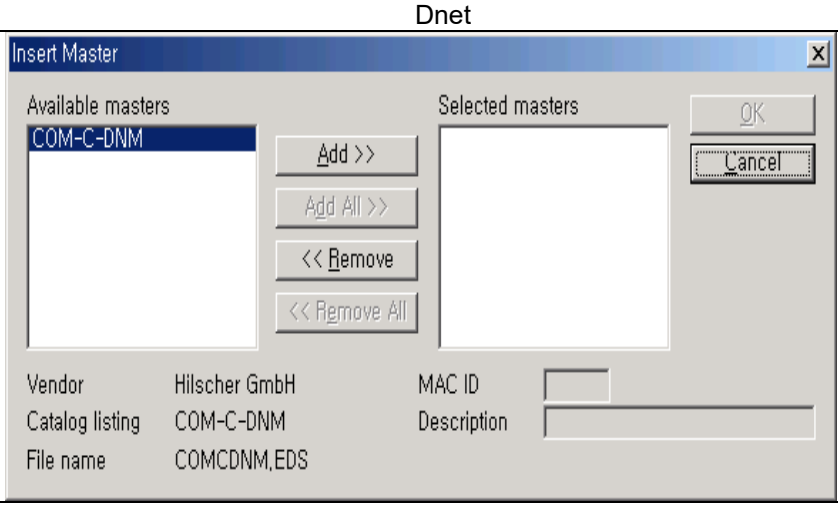
Classification	Dnet									
Master insert										
Master selection	<table border="1"> <thead> <tr> <th>Master type</th> <th>EDS File name</th> <th>Master name</th> </tr> </thead> <tbody> <tr> <td>XGT</td> <td>XGL-DMEA</td> <td>COMCDNM</td> </tr> <tr> <td></td> <td></td> <td>COM-C-DNM</td> </tr> </tbody> </table>	Master type	EDS File name	Master name	XGT	XGL-DMEA	COMCDNM			COM-C-DNM
Master type	EDS File name	Master name								
XGT	XGL-DMEA	COMCDNM								
		COM-C-DNM								

(3) Edit

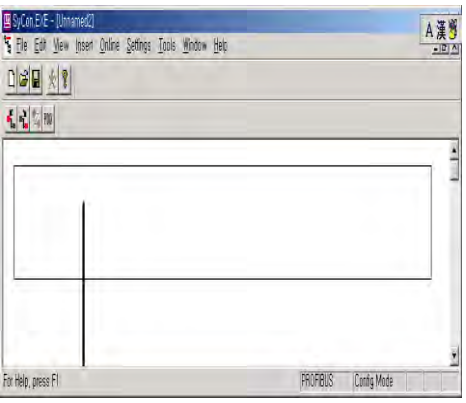
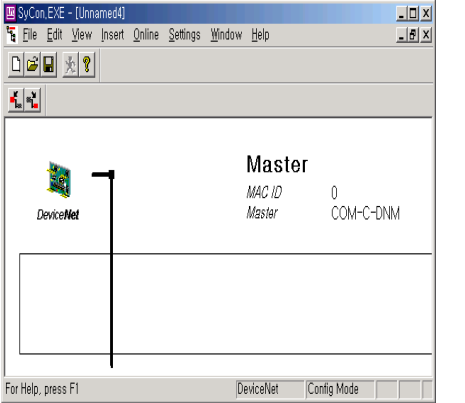
	Before edit	After edit
Master edit		

b) Slave

You can execute it after inserting master.

(1) Selection

Method	Selection sequence	Execution icon
Method by menu bar	Insert → Slave	
Method by icon		

(2) Insert

	Dnet																													
Slave insert																														
Slave selection	<table border="1"> <thead> <tr> <th>Slave type</th> <th>EDS File Name</th> <th>Slave name</th> </tr> </thead> <tbody> <tr> <td>DC input 16 point</td> <td>GDL-D22A</td> <td>GDL-D22A/D22C</td> </tr> <tr> <td>DC input 32 point</td> <td>GDL-D24A</td> <td>GDL-D24A/D24C</td> </tr> <tr> <td>DC input 16 point, Tr output 16 point</td> <td>GDL-DT4A</td> <td>GDL-DT4A/DT4A1/DT4B/DT4C/D54C1</td> </tr> <tr> <td>Relay output 16 point</td> <td>GDL-RY2A</td> <td>GDL-RY2A/R2C</td> </tr> <tr> <td>Tr output 16 point</td> <td>GDL-TR2A</td> <td>GDL-TR2A/TR2A1/TR2B/TR2C/TR2C1</td> </tr> <tr> <td>Tr output 32 point</td> <td>GDL-TR4A</td> <td>GDL-TR4A/TR4A1/TR4B/TR4C/TR4C1</td> </tr> <tr> <td>Extension type Smart I/O Dnet I/F module</td> <td>XDL-BSSA</td> <td>XDL-BSSA</td> </tr> <tr> <td>Inverter</td> <td>IS5V2_1</td> <td>IS5</td> </tr> </tbody> </table>	Slave type	EDS File Name	Slave name	DC input 16 point	GDL-D22A	GDL-D22A/D22C	DC input 32 point	GDL-D24A	GDL-D24A/D24C	DC input 16 point, Tr output 16 point	GDL-DT4A	GDL-DT4A/DT4A1/DT4B/DT4C/D54C1	Relay output 16 point	GDL-RY2A	GDL-RY2A/R2C	Tr output 16 point	GDL-TR2A	GDL-TR2A/TR2A1/TR2B/TR2C/TR2C1	Tr output 32 point	GDL-TR4A	GDL-TR4A/TR4A1/TR4B/TR4C/TR4C1	Extension type Smart I/O Dnet I/F module	XDL-BSSA	XDL-BSSA	Inverter	IS5V2_1	IS5		
Slave type	EDS File Name	Slave name																												
DC input 16 point	GDL-D22A	GDL-D22A/D22C																												
DC input 32 point	GDL-D24A	GDL-D24A/D24C																												
DC input 16 point, Tr output 16 point	GDL-DT4A	GDL-DT4A/DT4A1/DT4B/DT4C/D54C1																												
Relay output 16 point	GDL-RY2A	GDL-RY2A/R2C																												
Tr output 16 point	GDL-TR2A	GDL-TR2A/TR2A1/TR2B/TR2C/TR2C1																												
Tr output 32 point	GDL-TR4A	GDL-TR4A/TR4A1/TR4B/TR4C/TR4C1																												
Extension type Smart I/O Dnet I/F module	XDL-BSSA	XDL-BSSA																												
Inverter	IS5V2_1	IS5																												

(3) Edit

	Before edit	After edit
Slave edit		

5) Master setting

In order to set master, first you should select master which is set in the edit window .

a) Setting sequence

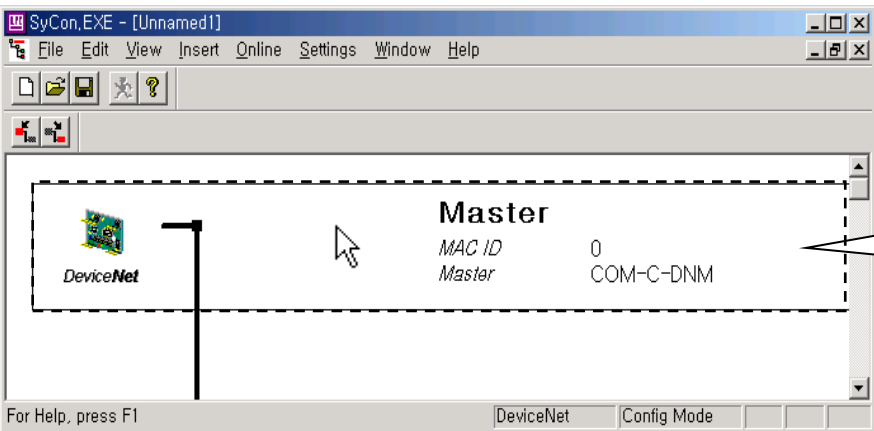
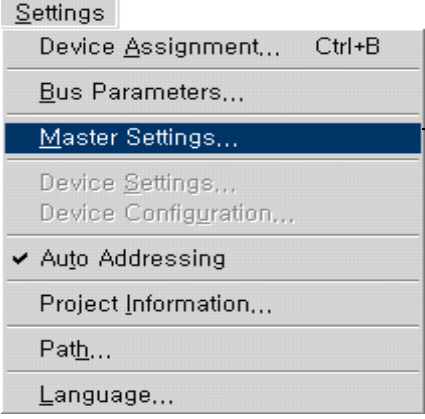
Step	Selection
1	<p>Master selection in the edit window</p>  <p>For Help, press F1 DeviceNet Config Mode</p>
2	<p>Master setting: Settings → Master Settings selection</p> 

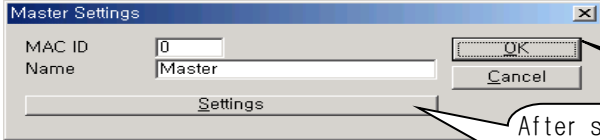
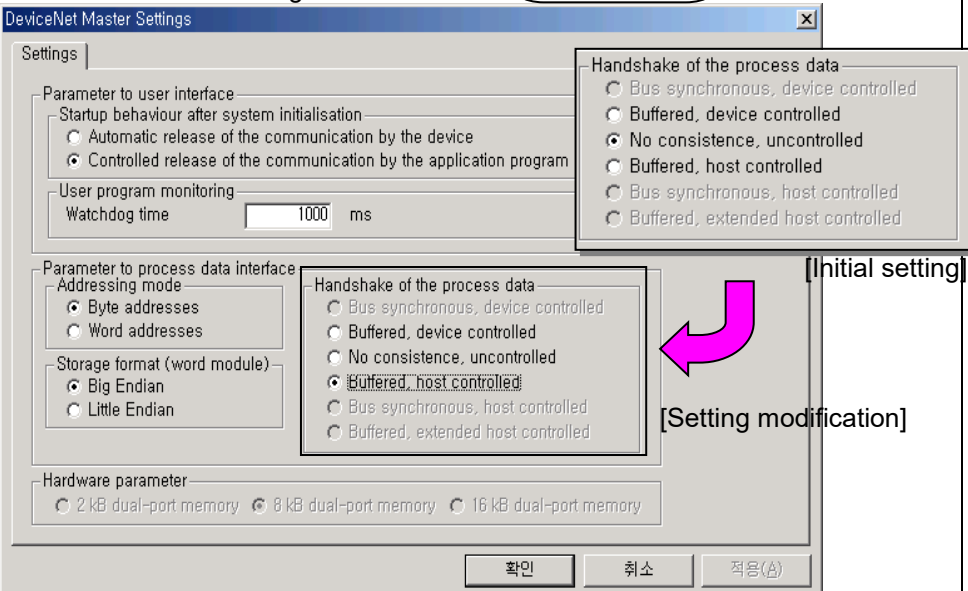
Step	selection
<p>1) When setting or modifying the MAC ID and master name.</p>  <p>2) Settings selection DeviceNet Master Setting</p> 	<p>After selecting, modify setting value</p> <p>And Selection</p> <p>[Initial setting]</p> <p>[Setting modification]</p>
<p>3</p>	<p>change from 'No consistence, uncontrolled' to 'Buffered, host controlled' in the Handshake of the process data</p> <p>(1) Parameter To user interface: Don't change basic value Basic value: a) Start behaviour after system Initialization → Controlled release of the communication by the application program b) user program monitoring → Watch dog time : 1000 (ms)</p> <p>(2) Parameter to process data interface: Don't change basic value. Basic value: a) Address Mode: Byte addresses b) Storage Format(Word Module): Big Endian</p> <p>(3) Handshake of the process data - select Buffered, host controlled</p>

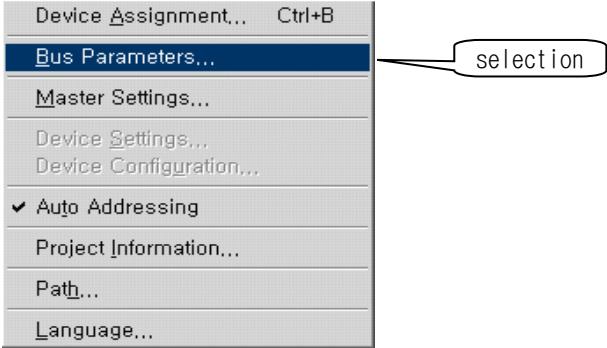
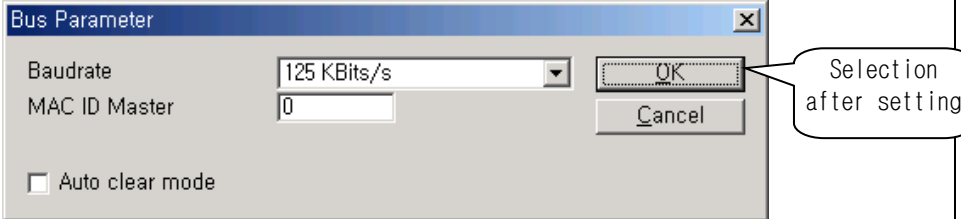
Step	selection
4	<p>Bus parameter setting: select Settings → Bus Parameters</p>  <p>▶ when changing communication speed and MAC ID Master value</p>  <ol style="list-style-type: none"> 1) Baudrate: selection among 125, 250, 500 KBits/s 2) MAC ID Master: selection among 0 ~ 63 3) Auto Clear Mode <ol style="list-style-type: none"> (1) When selecting it <ul style="list-style-type: none"> → If error occurs in the slave module, stop communicating with whole system → Dnet I/F module's HS LED flicker MNS LED red flicker (2) When not selecting it <ul style="list-style-type: none"> → If error occurs in the slave module, continue communicating with normal slave module.

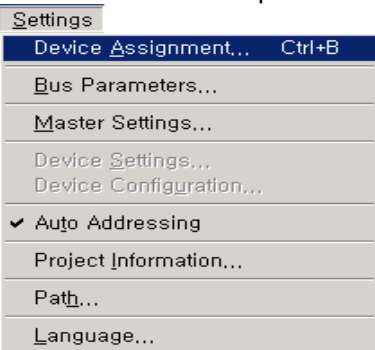
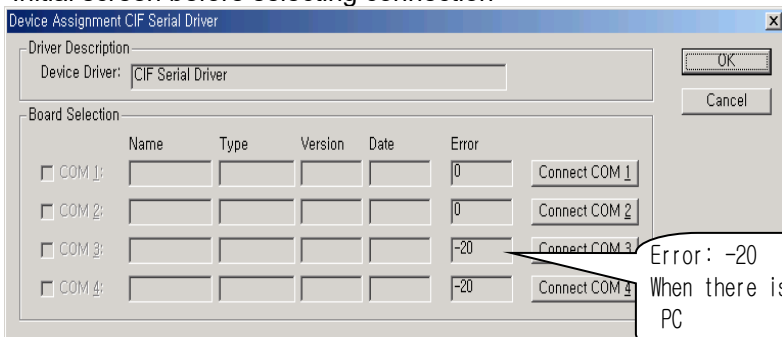
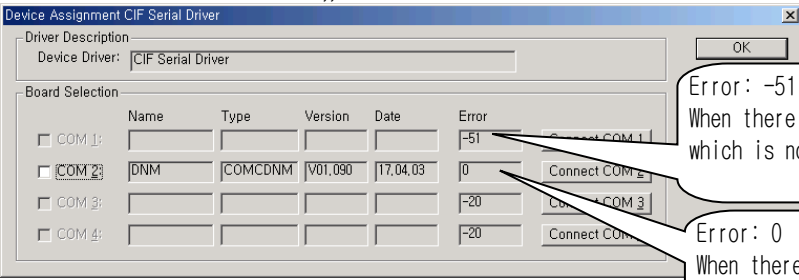
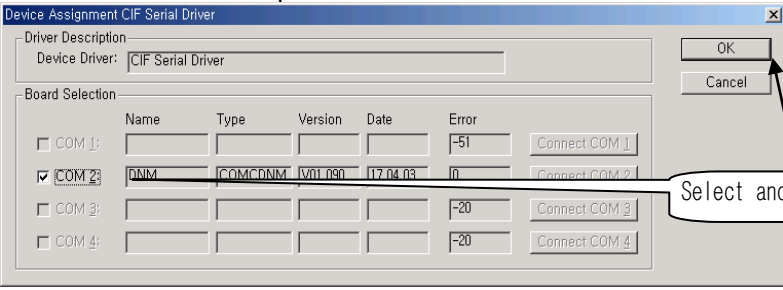
Step	selection
	<p>Serial port selection: Settings → Device Assignment selection →selects connected port among COM port of PC.</p>  <p>1) Initial screen before selecting connection</p>  <p>Error: -20 When there is no COM Port in the PC</p> <p>5 2) Check whether COM port is connected or not → select 'Connect COM1,, COM4' and check</p>  <p>Error: -51 When there is COM Port which is not connected.</p> <p>Error: 0 When there is COM Port which is connected.</p> <p>3) Select the connected port</p>  <p>Select and click OK</p>

Step Selection

Sets network automatically: OnLine → select **Automatic Network Scan**
 → Scans system information of configured slave automatically.

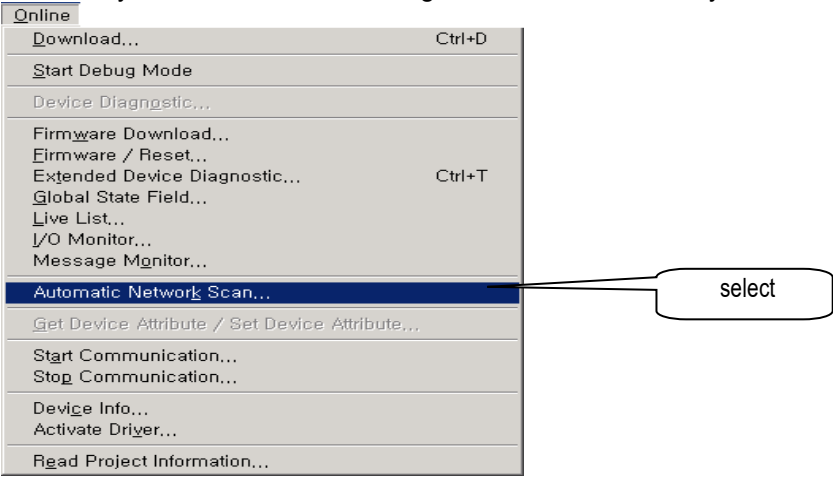

1) screen before scan

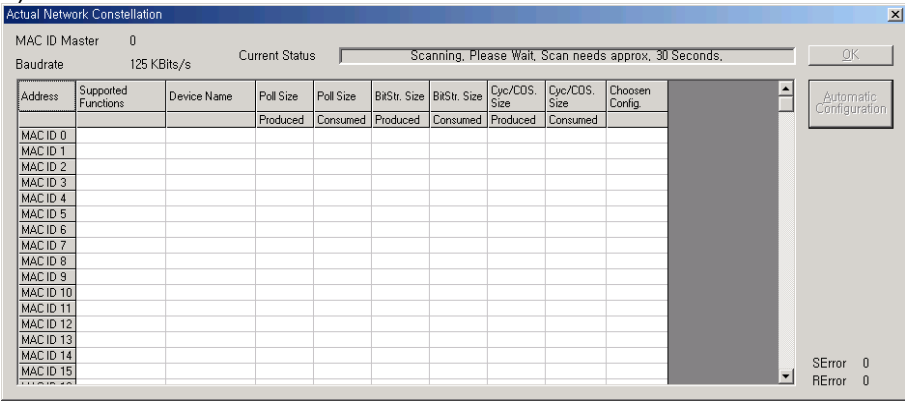

6

2) screen after scan

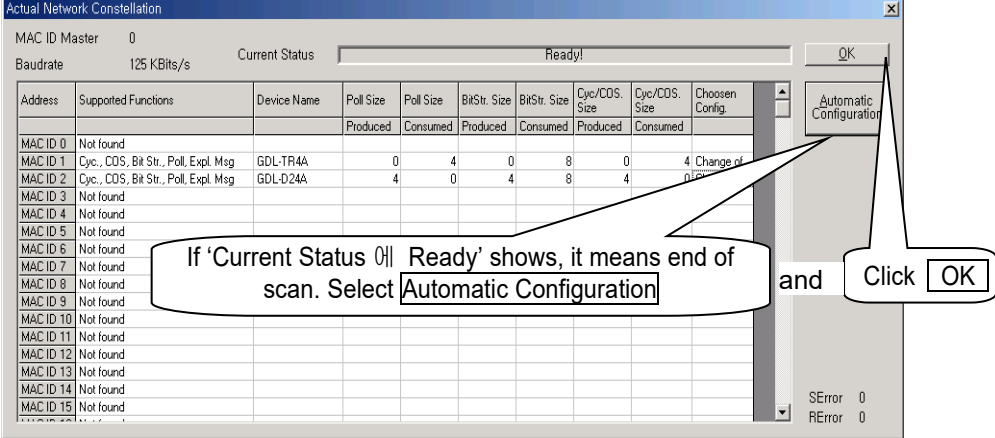

If 'Current Status' is 'Ready' shows, it means end of scan. Select **Automatic Configuration** and Click **OK**

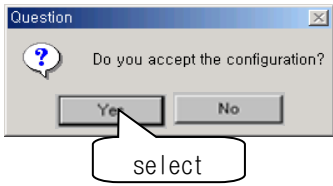
Step	Selection																																														
6	<p>→ Indicates information of slave which is configured at the network.</p> <div style="border: 1px solid gray; padding: 5px;"> <p>Actual Network Constellation</p> <p>① MAC ID Master 0</p> <p>② Baudrate 125 KBits/s ③ Current Status Ready!</p> <table border="1" style="width: 100%; border-collapse: collapse; text-align: center;"> <thead> <tr> <th rowspan="2">④ Address</th> <th rowspan="2">⑤ Supported Functions</th> <th rowspan="2">⑥ Device Name</th> <th colspan="2">⑦ Poll Size</th> <th colspan="2">⑧ BitStr. Size</th> <th colspan="2">⑨ Cyc/COS. Size</th> <th rowspan="2">⑩ Chosen Config.</th> </tr> <tr> <th>Produced</th> <th>Consumed</th> <th>Produced</th> <th>Consumed</th> <th>Produced</th> <th>Consumed</th> </tr> </thead> <tbody> <tr> <td>MAC ID 0</td> <td>Not found</td> <td></td> <td></td> <td></td> <td></td> <td></td> <td></td> <td></td> <td></td> </tr> <tr> <td>MAC ID 1</td> <td>Cyc., COS, Bit</td> <td>GDL-TR4A</td> <td>0</td> <td>4</td> <td>0</td> <td>8</td> <td>0</td> <td>4</td> <td>Change of</td> </tr> <tr> <td>MAC ID 2</td> <td>Cyc., COS, Bit</td> <td>GDL-D24A</td> <td>4</td> <td>0</td> <td>4</td> <td>8</td> <td>4</td> <td>0</td> <td>Change of</td> </tr> </tbody> </table> </div>	④ Address	⑤ Supported Functions	⑥ Device Name	⑦ Poll Size		⑧ BitStr. Size		⑨ Cyc/COS. Size		⑩ Chosen Config.	Produced	Consumed	Produced	Consumed	Produced	Consumed	MAC ID 0	Not found									MAC ID 1	Cyc., COS, Bit	GDL-TR4A	0	4	0	8	0	4	Change of	MAC ID 2	Cyc., COS, Bit	GDL-D24A	4	0	4	8	4	0	Change of
	④ Address				⑤ Supported Functions	⑥ Device Name	⑦ Poll Size		⑧ BitStr. Size			⑨ Cyc/COS. Size		⑩ Chosen Config.																																	
		Produced	Consumed	Produced			Consumed	Produced	Consumed																																						
	MAC ID 0	Not found																																													
MAC ID 1	Cyc., COS, Bit	GDL-TR4A	0	4	0	8	0	4	Change of																																						
MAC ID 2	Cyc., COS, Bit	GDL-D24A	4	0	4	8	4	0	Change of																																						
<table border="1" style="width: 100%; border-collapse: collapse;"> <thead> <tr> <th>No.</th> <th>Category</th> <th>Contents</th> </tr> </thead> <tbody> <tr> <td>①</td> <td>MAC ID Master : 0</td> <td>Indicates master station address</td> </tr> <tr> <td>②</td> <td>Baudrate : 125KBits/s</td> <td>Indicates the communication speed</td> </tr> <tr> <td>③</td> <td>Current Status</td> <td>Indicates process sequence Ready: complete Automatic Network Scan</td> </tr> <tr> <td>④</td> <td>Address : MAC ID 0 ~ MAC ID 63</td> <td>Indicates Max. No. of station to connect the network.</td> </tr> <tr> <td>⑤</td> <td>Supported Functions</td> <td>Indicates communication method slave module supplies -Cyclic, COS, Bit-Strobe, Poll</td> </tr> <tr> <td>⑥</td> <td>Device Name</td> <td>Connected slave device name</td> </tr> <tr> <td rowspan="2">⑦</td> <td rowspan="2">Poll Size</td> <td>Produced -transmits data from slave module to master module -indicates input module information -indicate module's point No. and unit is byte.</td> </tr> <tr> <td>Consumed -transmits data from master module to slave module -indicates output module information - indicates module's point No. and unit is byte</td> </tr> <tr> <td rowspan="2">⑧</td> <td rowspan="2">BitStr. Size</td> <td>Produced -transmits data from slave module to master module -indicate input module information - indicates module's point No. and unit is Byte</td> </tr> <tr> <td>Consumed - transmits data from master module to slave module - indicates output module information -Indicates information of Max. station and unit is byte</td> </tr> <tr> <td rowspan="2">⑨</td> <td rowspan="2">Cyc/COS. Size</td> <td>Produced - transmits data from slave module to master module - indicate input module information - indicates module's point No. and unit is Byte</td> </tr> <tr> <td>Consumed - transmits data from master module to slave module - indicates output module information - indicates module's point No. and unit is Byte</td> </tr> <tr> <td>⑩</td> <td>Chosen Config</td> <td>The user sets slave module's communication method -setting type: Cyclic, COS, Bit-Strobe, Poll -setting method: click cell by mouse</td> </tr> </tbody> </table>	No.	Category	Contents	①	MAC ID Master : 0	Indicates master station address	②	Baudrate : 125KBits/s	Indicates the communication speed	③	Current Status	Indicates process sequence Ready: complete Automatic Network Scan	④	Address : MAC ID 0 ~ MAC ID 63	Indicates Max. No. of station to connect the network.	⑤	Supported Functions	Indicates communication method slave module supplies -Cyclic, COS, Bit-Strobe, Poll	⑥	Device Name	Connected slave device name	⑦	Poll Size	Produced -transmits data from slave module to master module -indicates input module information -indicate module's point No. and unit is byte.	Consumed -transmits data from master module to slave module -indicates output module information - indicates module's point No. and unit is byte	⑧	BitStr. Size	Produced -transmits data from slave module to master module -indicate input module information - indicates module's point No. and unit is Byte	Consumed - transmits data from master module to slave module - indicates output module information -Indicates information of Max. station and unit is byte	⑨	Cyc/COS. Size	Produced - transmits data from slave module to master module - indicate input module information - indicates module's point No. and unit is Byte	Consumed - transmits data from master module to slave module - indicates output module information - indicates module's point No. and unit is Byte	⑩	Chosen Config	The user sets slave module's communication method -setting type: Cyclic, COS, Bit-Strobe, Poll -setting method: click cell by mouse											
No.	Category	Contents																																													
①	MAC ID Master : 0	Indicates master station address																																													
②	Baudrate : 125KBits/s	Indicates the communication speed																																													
③	Current Status	Indicates process sequence Ready: complete Automatic Network Scan																																													
④	Address : MAC ID 0 ~ MAC ID 63	Indicates Max. No. of station to connect the network.																																													
⑤	Supported Functions	Indicates communication method slave module supplies -Cyclic, COS, Bit-Strobe, Poll																																													
⑥	Device Name	Connected slave device name																																													
⑦	Poll Size	Produced -transmits data from slave module to master module -indicates input module information -indicate module's point No. and unit is byte.																																													
		Consumed -transmits data from master module to slave module -indicates output module information - indicates module's point No. and unit is byte																																													
⑧	BitStr. Size	Produced -transmits data from slave module to master module -indicate input module information - indicates module's point No. and unit is Byte																																													
		Consumed - transmits data from master module to slave module - indicates output module information -Indicates information of Max. station and unit is byte																																													
⑨	Cyc/COS. Size	Produced - transmits data from slave module to master module - indicate input module information - indicates module's point No. and unit is Byte																																													
		Consumed - transmits data from master module to slave module - indicates output module information - indicates module's point No. and unit is Byte																																													
⑩	Chosen Config	The user sets slave module's communication method -setting type: Cyclic, COS, Bit-Strobe, Poll -setting method: click cell by mouse																																													
<p>4) If scan is finished, Ready shows at the Current Status → At this time, select Automatic Configuration and check to use scanned information in the SyCon → selects OK</p>																																															
<div style="text-align: center;">  </div>																																															

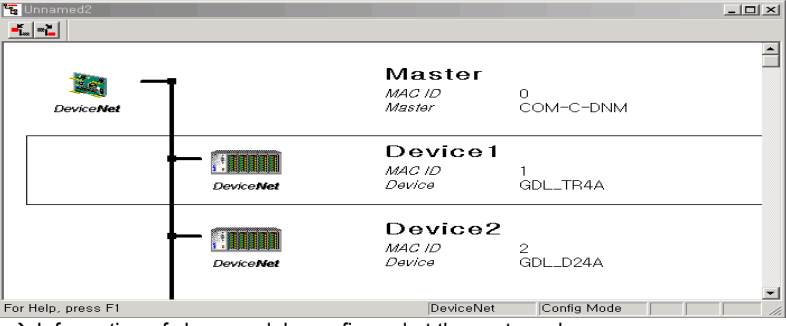
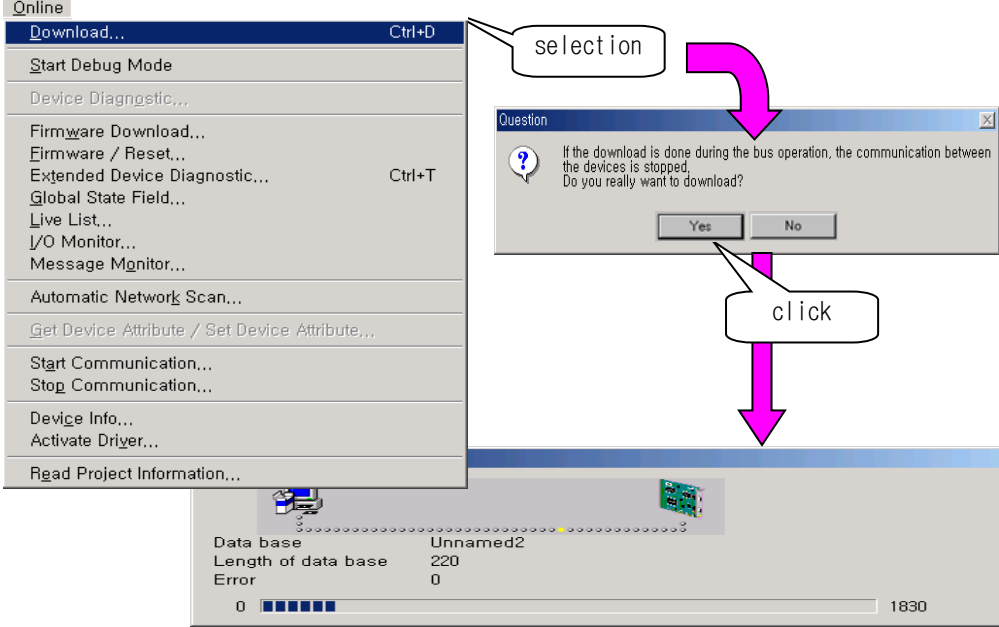
Step	Selection
6	<p>Edit window after completing Automatic Configuration</p>  <p>→ Information of slave module configured at the system shows. (In case that you equip analog module to extension type Smart I/O, in order to set analog module's parameter, double-click each module in the above figure and click 'Parameter Data' button in the 'Device Configuration window'. Then set analog module's parameter per each slot. For more details, refer to the Appendix.)</p>
7	<p>System configuration download: select OnLine → Download</p>  <p>→ If download is completed, Download window disappears.</p>
8	<p>Saves the edited system configuraion file:select File → Save or Save As</p>

If you complete the above 8 steps, you can communicate by High Speed Link and SyCon upload(**Online** → **SyCon upload**).

6) Slave module setting (manual setting)

In order to set slave module, select slave set in the edit window.

a) Setting sequence

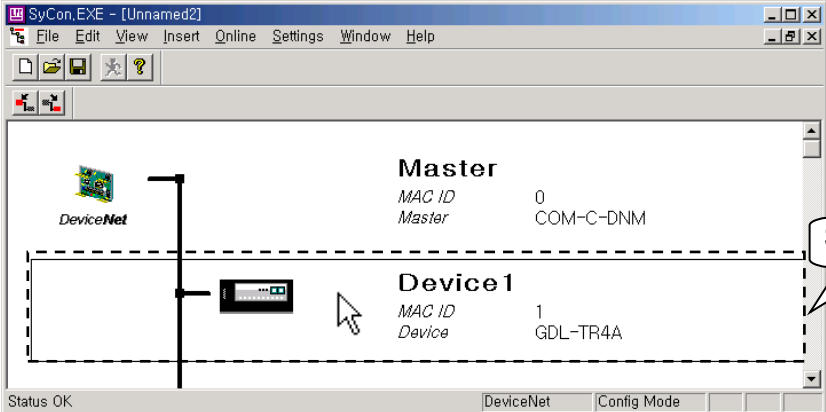
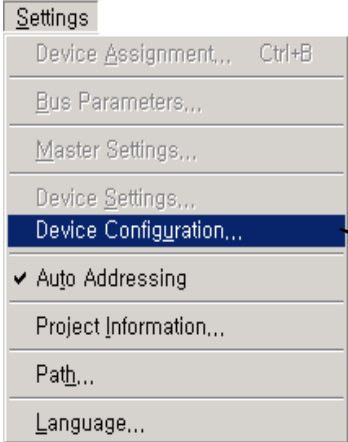
Step	selection
1	<p>Select slave in the edit window</p>  <p>The screenshot shows a window titled 'SyCon_EXE - [Unnamed2]' with a menu bar (File, Edit, View, Insert, Online, Settings, Window, Help) and a toolbar. The main area displays a DeviceNet network diagram. On the left, a 'Master' node is shown with 'MAC ID 0' and 'Master COM-C-DNM'. On the right, 'Device 1' is shown with 'MAC ID 1' and 'Device GDL-TR4A'. A dashed rectangular box encloses the 'Device 1' node. A mouse cursor is positioned over the device icon. A callout bubble with the text 'Select slave' points to the dashed box.</p>
2	<p>Slave setting : 1) select Settings → Device Configuration 2) select the slave in the edit window and click again by mouse</p>  <p>The screenshot shows the 'Settings' menu open. The menu items are: Device Assignment... Ctrl+B, Bus Parameters..., Master Settings..., Device Settings..., Device Configuration... (highlighted in blue), Auto Addressing (checked), Project Information..., Path..., and Language... A callout bubble with the text 'Selection' points to the 'Device Configuration...' menu item.</p>

Step	selection																											
3	<p>Slave setting parameter edit</p>																											
	<table border="1"> <thead> <tr> <th>No.</th> <th>Category</th> <th>Contents</th> </tr> </thead> <tbody> <tr> <td>①</td> <td>MAC ID & Description</td> <td>-setting the slave station address: 0~63 -setting slave explanation -Activate device in actual configuration 1) When selecting it: existing in the real network. 2) When not selecting it: not existing in the real network</td> </tr> <tr> <td>②</td> <td>Actual chosen IO Connection</td> <td>-select communication method slave supports: Cyclic, COS, Bit-Strobe, Poll -UCMM Check: It's for slave module which supports function</td> </tr> <tr> <td>③</td> <td>Actual Device</td> <td>Indicates slave configured at the network</td> </tr> <tr> <td>④</td> <td>Connection Object Instance Attributes</td> <td>-Expected Packet Rate: 1) COS method receiving period of output module. 2) Cyclic method sending/receiving period of I/O module -Production Inhibit Time: delay time between sending/receiving data. -Watchdog Timeout Action: in case of no response at the slave 1) Transition to timeout :hold error status 2) Auto Delete: delete from network automatically. 3) Auto Reset: return automatically. -Fragmented Timeout: Max. response time when sending data to slave module more than 8 byte. -Produced connection size: slave input data size -Consumed connection size: slave output data size</td> </tr> <tr> <td>⑤</td> <td>Parameter Data</td> <td>Analog module's parameter setting window</td> </tr> <tr> <td>⑥</td> <td>Available predefined Connection data types</td> <td>Data type: indicates data basic unit. Description: indicates input data or output data Data Length: indicates data size</td> </tr> <tr> <td>⑦</td> <td>Configured I/O Connection data and offset address</td> <td>Data type: indicates data basic unit Description: module name I Type: indicates input data's basic unit I Len: indicates input data size I Address: indicates input data start address O Type: indicates output data's basic unit O Len: indicates output data size O Address: indicates output data start address</td> </tr> <tr> <td>⑧</td> <td>OK</td> <td>Save setting value</td> </tr> </tbody> </table>	No.	Category	Contents	①	MAC ID & Description	-setting the slave station address: 0~63 -setting slave explanation -Activate device in actual configuration 1) When selecting it: existing in the real network. 2) When not selecting it: not existing in the real network	②	Actual chosen IO Connection	-select communication method slave supports: Cyclic, COS, Bit-Strobe, Poll -UCMM Check: It's for slave module which supports function	③	Actual Device	Indicates slave configured at the network	④	Connection Object Instance Attributes	-Expected Packet Rate: 1) COS method receiving period of output module. 2) Cyclic method sending/receiving period of I/O module -Production Inhibit Time: delay time between sending/receiving data. -Watchdog Timeout Action: in case of no response at the slave 1) Transition to timeout :hold error status 2) Auto Delete: delete from network automatically. 3) Auto Reset: return automatically. -Fragmented Timeout: Max. response time when sending data to slave module more than 8 byte. -Produced connection size: slave input data size -Consumed connection size: slave output data size	⑤	Parameter Data	Analog module's parameter setting window	⑥	Available predefined Connection data types	Data type: indicates data basic unit. Description: indicates input data or output data Data Length: indicates data size	⑦	Configured I/O Connection data and offset address	Data type: indicates data basic unit Description: module name I Type: indicates input data's basic unit I Len: indicates input data size I Address: indicates input data start address O Type: indicates output data's basic unit O Len: indicates output data size O Address: indicates output data start address	⑧	OK	Save setting value
	No.	Category	Contents																									
	①	MAC ID & Description	-setting the slave station address: 0~63 -setting slave explanation -Activate device in actual configuration 1) When selecting it: existing in the real network. 2) When not selecting it: not existing in the real network																									
	②	Actual chosen IO Connection	-select communication method slave supports: Cyclic, COS, Bit-Strobe, Poll -UCMM Check: It's for slave module which supports function																									
	③	Actual Device	Indicates slave configured at the network																									
	④	Connection Object Instance Attributes	-Expected Packet Rate: 1) COS method receiving period of output module. 2) Cyclic method sending/receiving period of I/O module -Production Inhibit Time: delay time between sending/receiving data. -Watchdog Timeout Action: in case of no response at the slave 1) Transition to timeout :hold error status 2) Auto Delete: delete from network automatically. 3) Auto Reset: return automatically. -Fragmented Timeout: Max. response time when sending data to slave module more than 8 byte. -Produced connection size: slave input data size -Consumed connection size: slave output data size																									
	⑤	Parameter Data	Analog module's parameter setting window																									
⑥	Available predefined Connection data types	Data type: indicates data basic unit. Description: indicates input data or output data Data Length: indicates data size																										
⑦	Configured I/O Connection data and offset address	Data type: indicates data basic unit Description: module name I Type: indicates input data's basic unit I Len: indicates input data size I Address: indicates input data start address O Type: indicates output data's basic unit O Len: indicates output data size O Address: indicates output data start address																										
⑧	OK	Save setting value																										

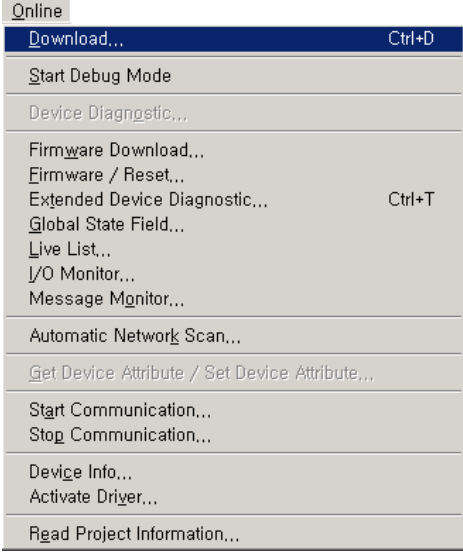
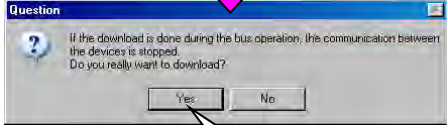
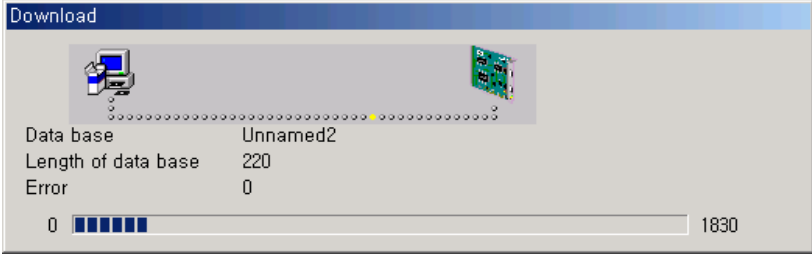
Step	selection
4	<p>System configuration download: select <u>O</u>nLine → <u>D</u>ownload → when conducting download, you should select master in the edit window.</p>    <p>→ If download is completed, <u>D</u>ownload window disappear.</p>
5	<p>Saves the edited system configuration file: select <u>F</u>ile → <u>S</u>ave or <u>S</u>ave As</p>

7) diagnosis

► In order to diagnose

- The file which is same with downloaded file should be in the edit window.
- You should select master in the edit window.
- In order to diagnose, meet the above 2 conditions.

► You can check station address, module name, communication speed, communication method and wiring through diagnosis.

a) Setting sequence

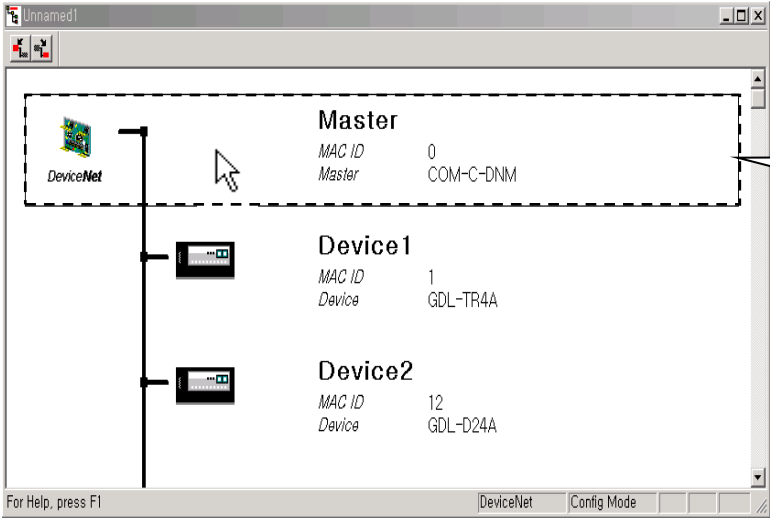
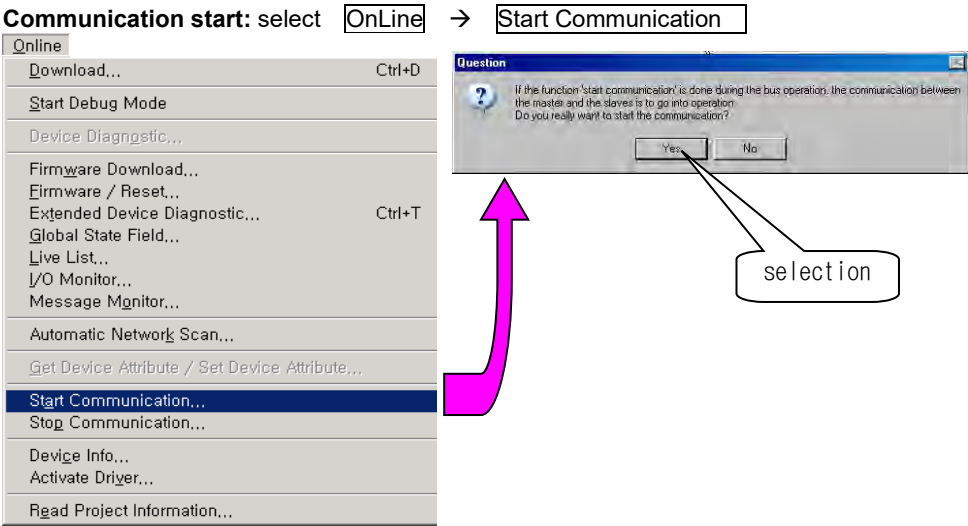
Step	selection
1	<p>Recall the file which is downloaded to Dnet I/F module in the edit window. → The file which is same with downloaded file should be in the edit window.</p>
2	<p>Select master in the edit window</p> 
3	<p>Communication start: select <input type="checkbox"/> OnLine → <input type="checkbox"/> Start Communication</p> 

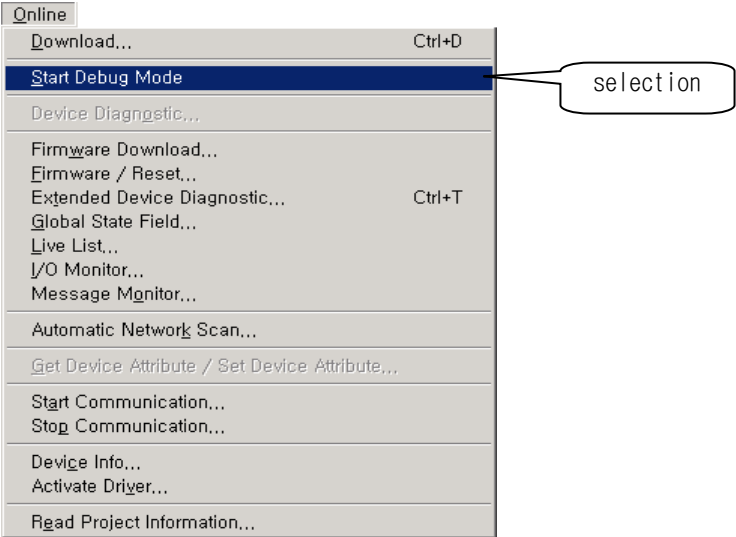
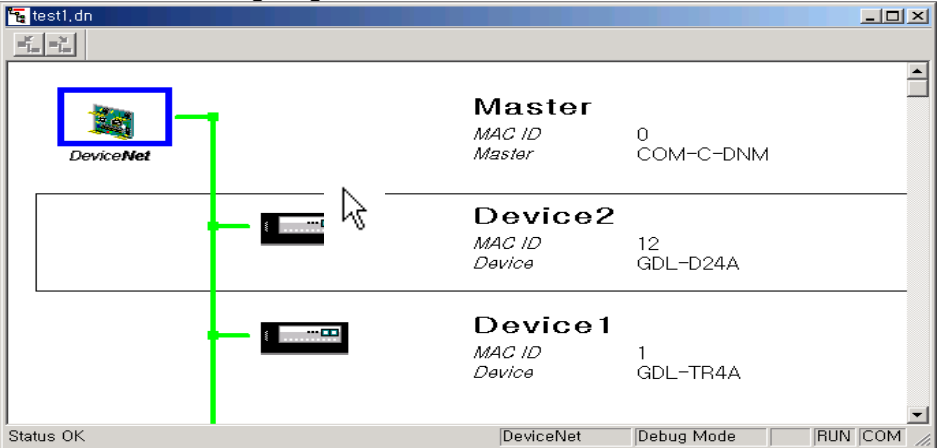
Step	Selection
	<p>Debug mode: select OnLine → Start Debug Mode</p> 
<p>4</p>	<p>When starting debug mode, wiring diagram shows in the edit window</p> <ol style="list-style-type: none"> 1) If it is normal, wiring diagram is indicated as green color. 2) If it is abnormal, wiring diagram is indicated as red color. 

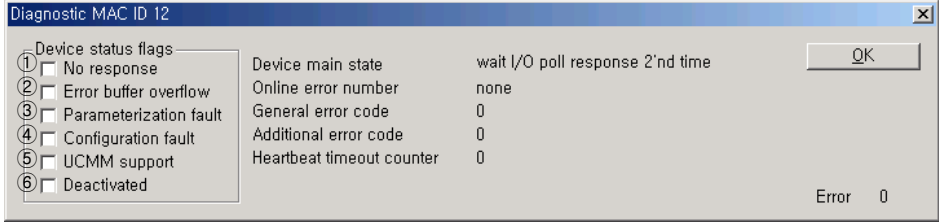
Step	selection																					
4	<p data-bbox="332 420 1313 483">In case of checking the slave's status, if you select the slave and click, the following screen shows.</p>  <p data-bbox="343 722 1037 752">According to slave module, Device status flags is checked.</p> <table border="1" data-bbox="365 792 1313 1268"> <thead> <tr> <th>No.</th> <th>Category</th> <th>contents</th> </tr> </thead> <tbody> <tr> <td>①</td> <td>No response</td> <td>When there is no designated slave module in the network. (solution: check the network cable and baudrate)</td> </tr> <tr> <td>②</td> <td>Error Buffer Overflow</td> <td>When error data information is overflowed at the limited buffer in the master module area</td> </tr> <tr> <td>③</td> <td>Parameterization Fault</td> <td>When information of slave module designated in the SyCon is different with information of module in the network.</td> </tr> <tr> <td>④</td> <td>Configuration Fault</td> <td>When I/O data size of slave module designated in the SyCon is different with real data size</td> </tr> <tr> <td>⑤</td> <td>UCMM Support</td> <td>When slave module supports UCMM.</td> </tr> <tr> <td>⑥</td> <td>Deactivated</td> <td>It indicates that slave module has error.</td> </tr> </tbody> </table>	No.	Category	contents	①	No response	When there is no designated slave module in the network. (solution: check the network cable and baudrate)	②	Error Buffer Overflow	When error data information is overflowed at the limited buffer in the master module area	③	Parameterization Fault	When information of slave module designated in the SyCon is different with information of module in the network.	④	Configuration Fault	When I/O data size of slave module designated in the SyCon is different with real data size	⑤	UCMM Support	When slave module supports UCMM.	⑥	Deactivated	It indicates that slave module has error.
No.	Category	contents																				
①	No response	When there is no designated slave module in the network. (solution: check the network cable and baudrate)																				
②	Error Buffer Overflow	When error data information is overflowed at the limited buffer in the master module area																				
③	Parameterization Fault	When information of slave module designated in the SyCon is different with information of module in the network.																				
④	Configuration Fault	When I/O data size of slave module designated in the SyCon is different with real data size																				
⑤	UCMM Support	When slave module supports UCMM.																				
⑥	Deactivated	It indicates that slave module has error.																				

(2) SyCon monitoring information

Here describes how to monitor diverse network status information in communicating.

(a) Global State Field

Method	Contents
Selection method	OnLine → Global State Field

Global State Field's content is as follows.

Classification	Contents	
OnLine Master main state	Operate	Master module is operating
	Stop	When master module's communication part does not work.
Collective Status Bits	PDUP	Device is checking MAC ID (duplex station address).
	DMAC	There is duplex station address in the network module.
	NRDY	Communication is not ready in the main program.
	EVE	There is error in sending.
	FAT	Communication is impossible because of severe error
	NEXC	At least one device does not reach Data Exchange State.
	ACLR	All devices stop communicating and are cleared automatically.
	CTRL	Master parameter error
Collective OnLine error location and corresponding error	Error at remote address	Indicates error station address
	corresponding error event	Indicates error contents
Statistic bus information	Counter of detected bus off report	Counts No. of the Bus off
	Counter of rejected telegram transmissions	Count No. of stopped transmission
Device specific status bits	Parameterized Devices	Indicates slave module where parameter is set (Blue)
	Activated Devices	Indicates operating slave module (green) - Green color disappears in the station address which has error.
	Devices with Diagnostic	Indicate operating slave module (red) - When double-clicking the red color station address, diagnosis window shows. →refer to 4 step of category (7)

(b) Live List

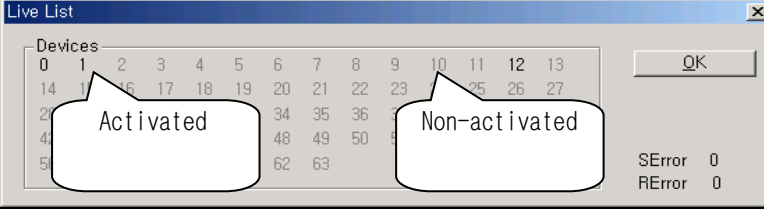
Method	Contents
Selection method	OnLine → Live List
<p>Online</p> <p>Download... Ctrl+D</p> <p>Start Debug Mode</p> <p>Device Diagnostic...</p> <p>Firmware Download...</p> <p>Firmware / Reset...</p> <p>Extended Device Diagnostic... Ctrl+T</p> <p>Global State Field...</p> <p>Live List...</p> <p>I/O Monitor...</p> <p>Message Monitor... selection</p> <p>Automatic Network Scan...</p> <p>Get Device Attribute / Set Device Attribute...</p> <p>Start Communication...</p> <p>Stop Communication...</p> <p>Device Info...</p> <p>Activate Driver...</p> <p>Read Project Information...</p>	 <p>The screenshot shows a 'Live List' dialog box with a table of device addresses. The table has 64 columns (0-63) and 6 rows (0-5). The status of each device is indicated by a checkmark (Activated) or an 'X' (Non-activated). Callouts point to device 1 (Activated) and device 10 (Non-activated). The dialog also shows 'SErrors: 0' and 'RErrors: 0'.</p> <p>Devices: indicate slave station address</p> <p>1) Activated: indicates slave module which conducts normal communication</p> <p>2) Non-activated: indicates slave module which does not conduct normal communication</p>

(3) XG5000 setting

If you execute XG5000, the following screen shows

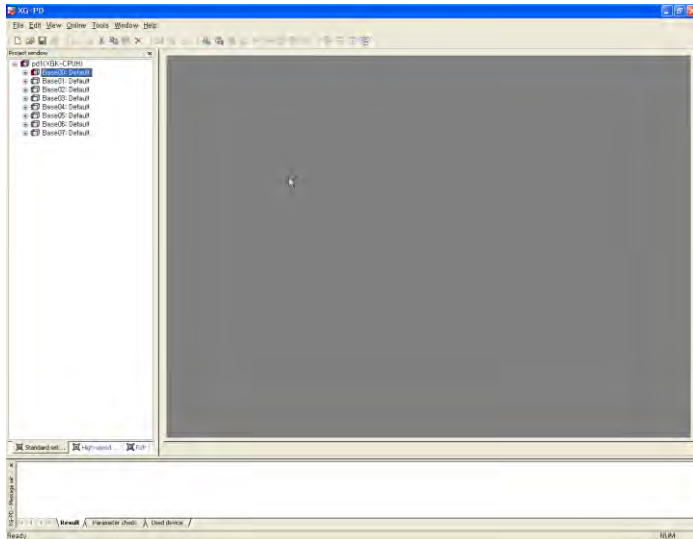

[Basic screen]

Parameter you can set in the XG5000 is as follows

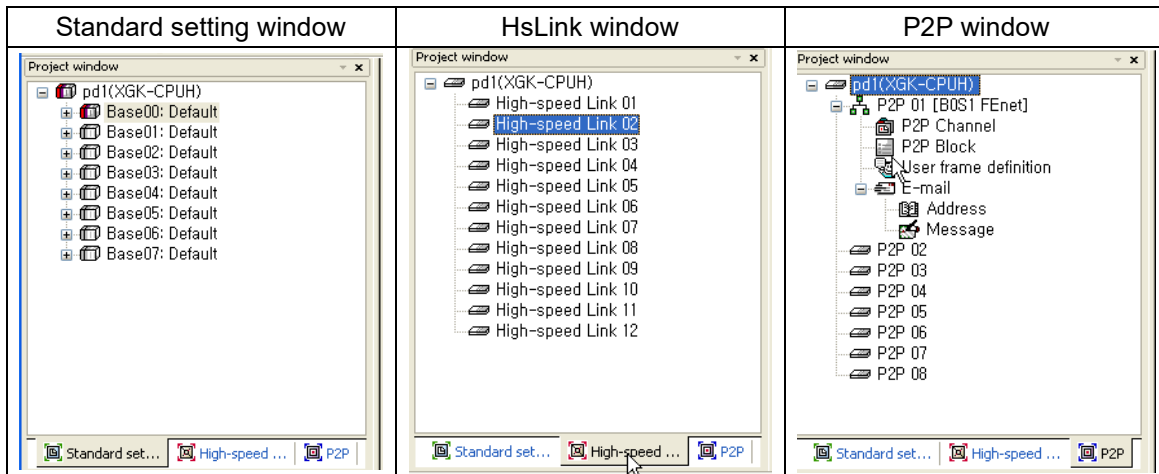

[Parameter window]

HsLink window is used in the Dnet I/F module.

You can set High-speed Link up to 12.

You can use one High-speed Link per one Dnet I/F module.

(a) How to use HSL window

If you select HSL window, you can set the parameter as shown below

There are two types of window (Communication module setting and HSL block setting window)

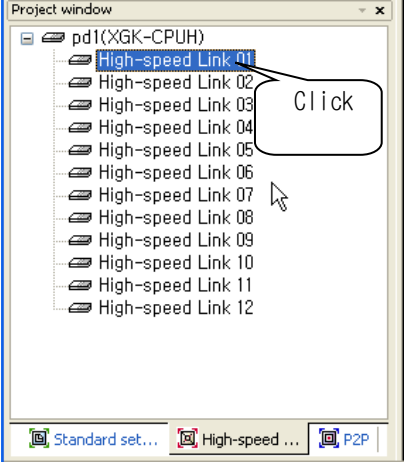
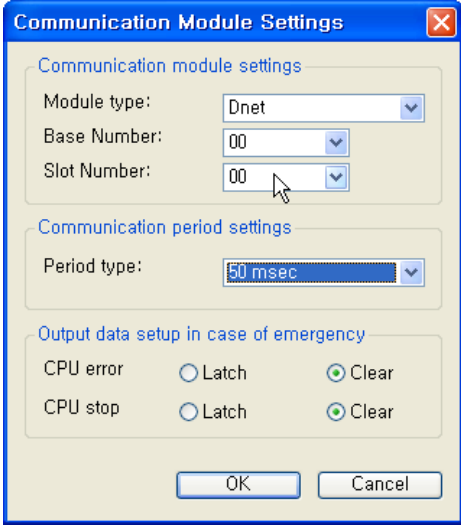
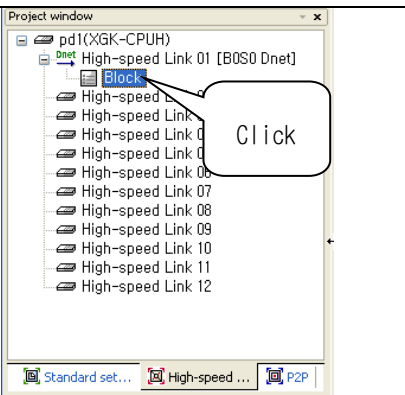
High-speed Link window	Parameter setting window																																																								
																																																									
	<p>High-speed Link block setting</p> <table border="1" data-bbox="612 1180 1268 1396"> <thead> <tr> <th>Index</th> <th>Mode</th> <th>Station number</th> <th>Communication method</th> <th>Read area</th> <th>Sending data (Byte)</th> <th>Save area</th> <th>Receiving data (Byte)</th> </tr> </thead> <tbody> <tr><td>0</td><td></td><td></td><td></td><td></td><td></td><td></td><td></td></tr> <tr><td>1</td><td></td><td></td><td></td><td></td><td></td><td></td><td></td></tr> <tr><td>2</td><td></td><td></td><td></td><td></td><td></td><td></td><td></td></tr> <tr><td>3</td><td></td><td></td><td></td><td></td><td></td><td></td><td></td></tr> <tr><td>4</td><td></td><td></td><td></td><td></td><td></td><td></td><td></td></tr> <tr><td>5</td><td></td><td></td><td></td><td></td><td></td><td></td><td></td></tr> </tbody> </table>	Index	Mode	Station number	Communication method	Read area	Sending data (Byte)	Save area	Receiving data (Byte)	0								1								2								3								4								5							
Index	Mode	Station number	Communication method	Read area	Sending data (Byte)	Save area	Receiving data (Byte)																																																		
0																																																									
1																																																									
2																																																									
3																																																									
4																																																									
5																																																									

Remark

The meaning of High-speed Link 01[B0S0 Dnet] is as follows

- 1) High-speed Link 01: indicates High-speed Link's No.
- 2) B0: indicates base's No. (example, extension base 2 step: B2, extension base 5step:B5)
- 3) S0: indicates slot's No. (example, slot 5: S5, slot 11: S11)

(b) Communication module setting parameter

You can set communication module setting parameter as follows.

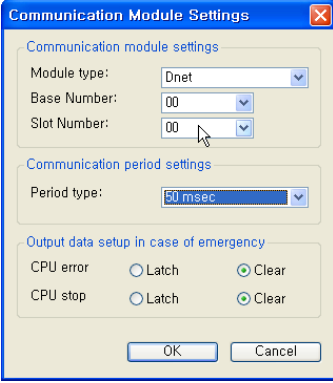
Parameter window	Setting category		Setting contents	
	Communication module setting	Module type	Select Dnet	
		Base No.	Setting range: 0 ~ 7 It's different according to CPU module	
		Slot No.	Setting range: 0 ~ 11 It's different according to base type	
	Communication period setting (period type)	Select among 10ms, 20ms, 50ms, 100ms, 200ms, 500ms, 1s, 5s, 10s - Default is set as 10ms. - It's applied to sending data - The receiving data is processed every 'End' of scan program		
	Output data setting when emergency	CPU Error	Latch	Hold output state (But P device is cleared)
			Clear	Clear output data
CPU stop		Latch	Hold output state (But P device is cleared)	
		Clear	Clear output data	

Click **OK** button and finish the parameter setting.

Remark

Notice in setting the communication period

- 1) Communication period setting value is sending data period. (CPU module's data → Dnet I/F module)
If you set communication period loner than data change time written in the scan program, the data transmitted to slave module is indicated differently with program's data

(c) High-speed Link block setting parameter

You can set High-speed Link block setting parameter as follows.

1) SyCon upload

Before setting high-speed link block, you should upload SyCon.

Upload method: online → SyCon upload (Dnet, Pnet)

Classification	High-speed link block setting window							
Before upload	Index	Mode	Station number	Communication method	Read area	Sending data (Byte)	Save area	Receiving data (Byte)
	0							
	1							
	2							
	3							
	4							
	5							
	6							
After upload	Index	Mode	Station number	Communication method	Read area	Sending data (Byte)	Save area	Receiving data (Byte)
	0	Send/Receive	1	COS		32		16
	1	Send/Receive	2	COS		20		28
	2	Send/Receive	3	COS		22		24
	3	Send/Receive	4	COS		2		2
	4	Send/Receive	5	COS		6		15
	5	Send/Receive	6	COS		6		2
6	Send	7	COS		6		2	

If you do upload, information designated at the SyCon show in the HSL block setting window. If setting about 'reading area' and 'storage area' is completed, letter written by red color change into black color.

You can see the following information you can read after upload.

Category	contents
Index	Read information from block who has low station address and display it from 0
Station	indicates station address of slave module in the network
Communication method	Indicates contents designated at the SyCon among 4 communication methods (Poll, Bit-Strobe, Cyclic, COS)
Reading area	First address of device you want to send from master module to slave module
Sending data	Indicates slave module's size by byte.
Storage area	First address of device you want to receive in slave module
Receiving area	Indicates slave module's size by byte.

You can't use the uploaded SyCon information by saving file edited at the XG5000. So when you monitor by XG5000 file, upload it to SyCon again.

2) Editing High-speed Link block

The contents you can edit in the high-speed link block is first address you want to send/receive.

classification	contents																																																																
Uploaded window	<table border="1"> <thead> <tr> <th>Index</th> <th>Mode</th> <th>Station number</th> <th>Communication method</th> <th>Read area</th> <th>Sending data (Byte)</th> <th>Save area</th> <th>Receiving data (Byte)</th> </tr> </thead> <tbody> <tr> <td>0</td> <td>Send/Receive</td> <td>1</td> <td>COS</td> <td></td> <td>32</td> <td></td> <td>16</td> </tr> <tr> <td>1</td> <td>Send/Receive</td> <td>2</td> <td>COS</td> <td></td> <td>20</td> <td></td> <td>28</td> </tr> <tr> <td>2</td> <td>Send/Receive</td> <td>3</td> <td>COS</td> <td></td> <td>22</td> <td></td> <td>24</td> </tr> <tr> <td>3</td> <td>Send/Receive</td> <td>4</td> <td>COS</td> <td></td> <td>2</td> <td></td> <td>2</td> </tr> <tr> <td>4</td> <td>Send/Receive</td> <td>5</td> <td>COS</td> <td></td> <td>6</td> <td></td> <td>15</td> </tr> <tr> <td>5</td> <td>Send/Receive</td> <td>6</td> <td>COS</td> <td></td> <td>2</td> <td></td> <td>2</td> </tr> <tr> <td>6</td> <td>Send</td> <td>7</td> <td>COS</td> <td></td> <td>4</td> <td></td> <td></td> </tr> </tbody> </table>	Index	Mode	Station number	Communication method	Read area	Sending data (Byte)	Save area	Receiving data (Byte)	0	Send/Receive	1	COS		32		16	1	Send/Receive	2	COS		20		28	2	Send/Receive	3	COS		22		24	3	Send/Receive	4	COS		2		2	4	Send/Receive	5	COS		6		15	5	Send/Receive	6	COS		2		2	6	Send	7	COS		4		
	Index	Mode	Station number	Communication method	Read area	Sending data (Byte)	Save area	Receiving data (Byte)																																																									
	0	Send/Receive	1	COS		32		16																																																									
	1	Send/Receive	2	COS		20		28																																																									
	2	Send/Receive	3	COS		22		24																																																									
	3	Send/Receive	4	COS		2		2																																																									
	4	Send/Receive	5	COS		6		15																																																									
	5	Send/Receive	6	COS		2		2																																																									
6	Send	7	COS		4																																																												

HSL Block edit window	Category	contents		
	mode	sending: convey data from master module to slave module receiving: convey data from slave module to master module		
	Station address	Slave station address (range: 0 ~ 63)		
	Communication method	Communication method designated in the slave by SyCon		
	Reading area (master module → Slave module)	Address	First address of device you want to send Available device: P, M, K, F, T, C, U, Z, L, N, D, R, ZR	
		Size (Byte)	Indicates IO contact no. of slave module by byte -deals with IO module less than 8 bit as 1 byte	
	Storage area (slave module → Master module)	Address	First address of device you want to receive Available device: P, M, K, F, T, C, U, Z, L, N, D, R, ZR	
		Size (Byte)	Indicates IO contact no. of slave module by byte -deals with IO module less than 8 bit as 1 byte	

The slave module that has low station address has priority in processing.

Remark
Setting unit of address is byte. So when you set address, deal with 8 contact no. module or less than as 1 byte.

3) How to use HSL block editing tool

How to use HSL block editing tool is as follows.

Index	Mode	Station number	Communication method	Read area	Sending data (Byte)	Save area	Receiving data (Byte)
0	Send/Receive	1	COS		32		16
1	Send/Receive	2	COS		20		28
2	Send/Receive	3	COS		22		24
3	Send/Receive	4	COS		?		2
4	Send/Receive	5	COS				15
5	Send/Receive	6	COS				2
6	Send	7	COS				

If you select by mouse and click right button, The following screen shows.

Undo	When canceling the edited contents
Redo	When returning edited contents to the previous status
Cut	When cutting the edited contents
Copy	When copying the edited index
Paste	When pasting the edited index
Delete	When deleting the edited index

When indicating HSL block by tree structure

Undo	Ctrl+Z
Redo	Ctrl+R
Cut	Ctrl+X
Copy	Ctrl+C
Paste	Ctrl+V
Delete	Delete

View tree by Transmission/Reception

[screen 1]

View tree by Transmission/reception

Screen1: locate the mouse over the HSL block window and click right mouse button.

The following screen used when reading or writing HSL parameter.

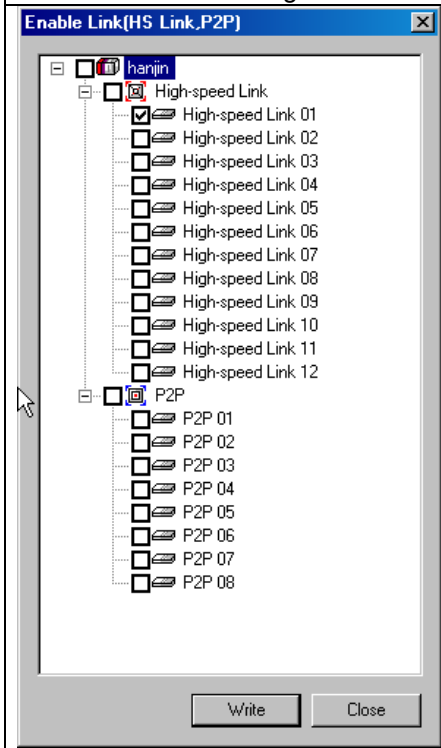
Screen configuration	contents
	<ol style="list-style-type: none"> 1) You can set max. 12 HSL parameter 2) You can read/write about HSL parameter respectively. -You select it by click left mark of HSL by mouse. 3) reading/writing HSL parameter is not affect by CPU module's run mode.

When you write HSL parameter to CPU module, the CPU module has that data.

So when you change CPU module, read HSL parameter from CPU module and back up it and write it to new CPU module.

6.4 Analog I/O module Parameter Setting

6.4.1 XDL-BSSA Analog I/O module Parameter Setting

Type and parameter setting of analog I/O module available to be installed at XDL-BSSA are as follows.

▶ XBF-AD04A

Address	7	6	5	4	3	2	1	0	Meaning
0	-	-	-	-	CH3	CH2	CH1	CH0	<CH Enable_ lower byte> Bit On(1) : Enable Bit Off(0): Disable
1	CH3		CH2		CH1		CH0		<Input voltage/current range> Bit(00):0~10V Bit(01):0~20mA Bit(10):4~20mA
2	CH3		CH2		CH1		CH0		<Output data range> Bit(00): 0~4000 Bit(01):-2000~2000 Bit(10): precise value (0~1000/400~2000/0~2000) Bit(11):percentile value (0~1000)

▶ XBF-DV04A

Address	7	6	5	4	3	2	1	0	Meaning
0	-	-	-	-	CH3	CH2	CH1	CH0	<CH Enable_ lower byte> Bit On(1) : Enable Bit Off(0): Disable
1	CH3		CH2		CH1		CH0		<Voltage range> Bit (00): 0 ~ 10V
2	CH3		CH2		CH1		CH0		<Input data type> Bit (00): 0 ~ 4000 Bit (01): -2000 ~ 2000 Bit (10): 0 ~ 1000 Bit (11): 0 ~ 1000

▶ XBF-DC04A

Address	7	6	5	4	3	2	1	0	Meaning
0	-	-	-	-	CH 3	CH 2	CH 1	CH 0	<CH Enable_lower byte> Bit On(1) : enable Bit Off(0): disable
1	CH 3		CH 2		CH 1		CH 0		<Current range> Bit (00): 4 ~ 20mA Bit (01): 0 ~ 20mA
2	CH 3		CH 2		CH 1		CH 0		<Input data type> Bit (00): 0 ~ 4000 Bit (01): -2000 ~ 2000 Bit (10): 400 ~ 2000/ 0 ~ 2000 Bit (11): 0 ~ 1000

▶ XBF-RD04A

Address	7	6	5	4	3	2	1	0	Meaning
0	CH 3	CH 2	CH 1	CH 0	CH 3	CH 2	CH 1	CH 0	<CH Enable_lower byte> Bit On(1) : enable Bit Off(0): disable <Temp. unit_upper byte> Bit On(1): Fahrenheit Bit Off(0): Celsius
1	-	-	-	-	CH 3	CH 2	CH 1	CH 0	<Sensor input range> Bit On(1) : JPT100 Bit Off(0): PT100

▶ XBF-TC04S

Address	7	6	5	4	3	2	1	0	Meaning
0	CH 3	CH 2	CH 1	CH 0	CH 3	CH 2	CH 1	CH 0	<CH Enable_lower byte> Bit On(1): enable Bit Off(0): disable <Temp. unit_upper byte> Bit On(1): Fahrenheit Bit Off(0): Celsius
1	CH 3		CH 2		CH 1		CH 0		<Sensor input type> K type: 00, J type: 01 T type: 10, R type: 11

▶ XBF-AH04A

Address	7	6	5	4	3	2	1	0	Meaning
0	INPUT CH 1				INPUT CH 0				<I/O range> Bit(0000): 4 ~ 20 mA Bit(0001): 0 ~ 20 mA Bit(0010): 1 ~ 5 V Bit(0011): 0 ~ 5 V Bit(0100): 0 ~ 10 V
1	OUTPUT CH 1				OUTPUT CH 0				
2	OUTPUT CH 1	OUTPUT CH 0	INPUT CH 1	INPUT CH 0	<I/O data type> Bit(00): 0 ~ 4000 Bit(01): -2000 ~ 2000 Bit(10): Precise value Bit(11): 0 ~ 1000 - In case of precise value 4 ~ 20 mA: 400 ~ 2000 0 ~ 20 mA: 0 ~ 2000 1 ~ 5 V: 100 ~ 500 0 ~ 5 V: 0 ~ 500 0 ~ 10 V: 0 ~ 1000				

Note**Cautions in setting an analog parameter**

- (1) For analog I/O module, all channels are set as Enable status internally.
- (2) A setting parameter is sent from master to slave.

6.4.2 How to set XDL-BSSA analog I/O module parameter

Dnet adapter, slave module is configured at SyCon. At this time, EDS file of XDL-BSSA is necessary. How to set is as follows.

- ▶ Double-click a XDL-BSSA at SyCon

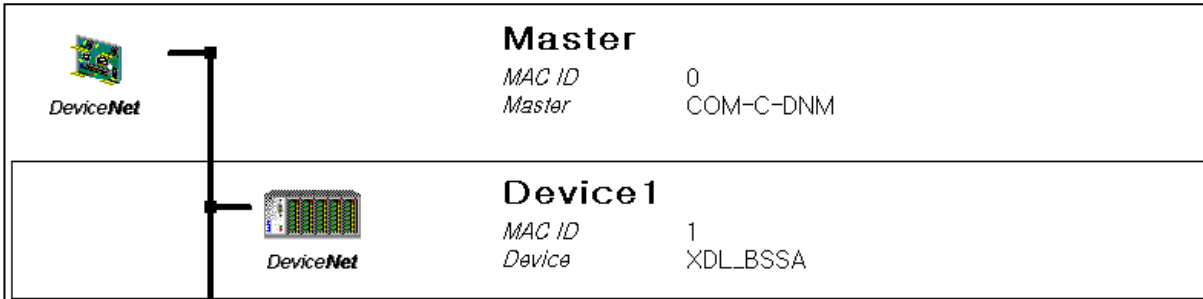

- ▶ Click "Parameter Data..." button

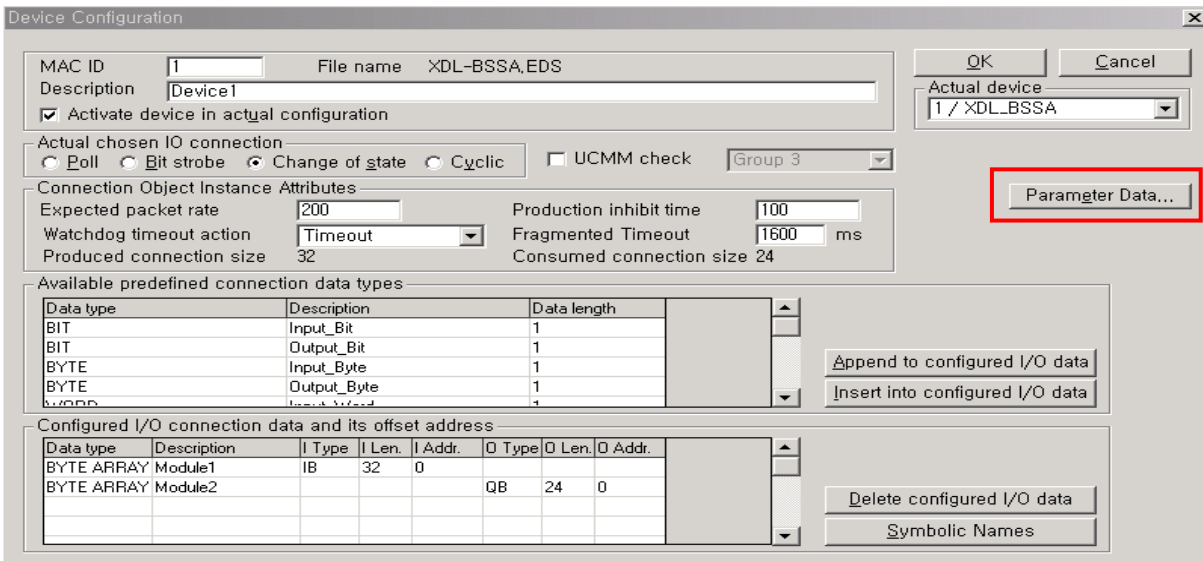

- ▶ Select slot you want to set and double-click it at Available Parameters window. Then Customized Parameters window appears.

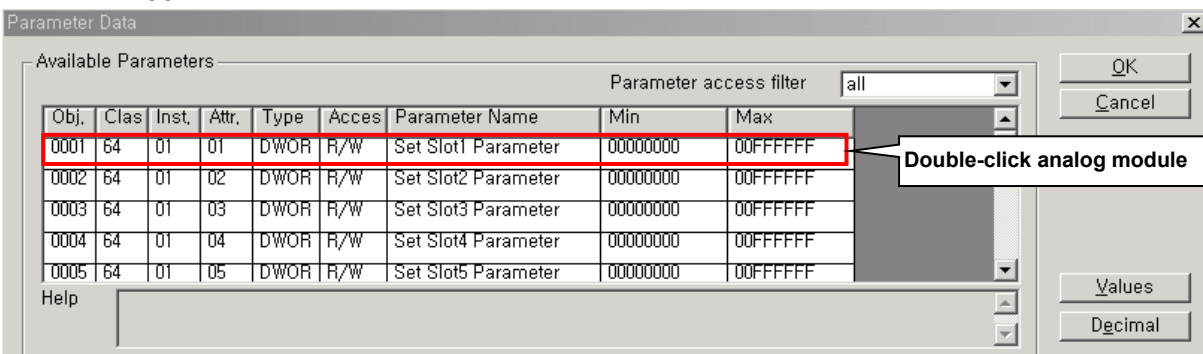

► Input a parameter at 'Value' of **Customized Parameters** window

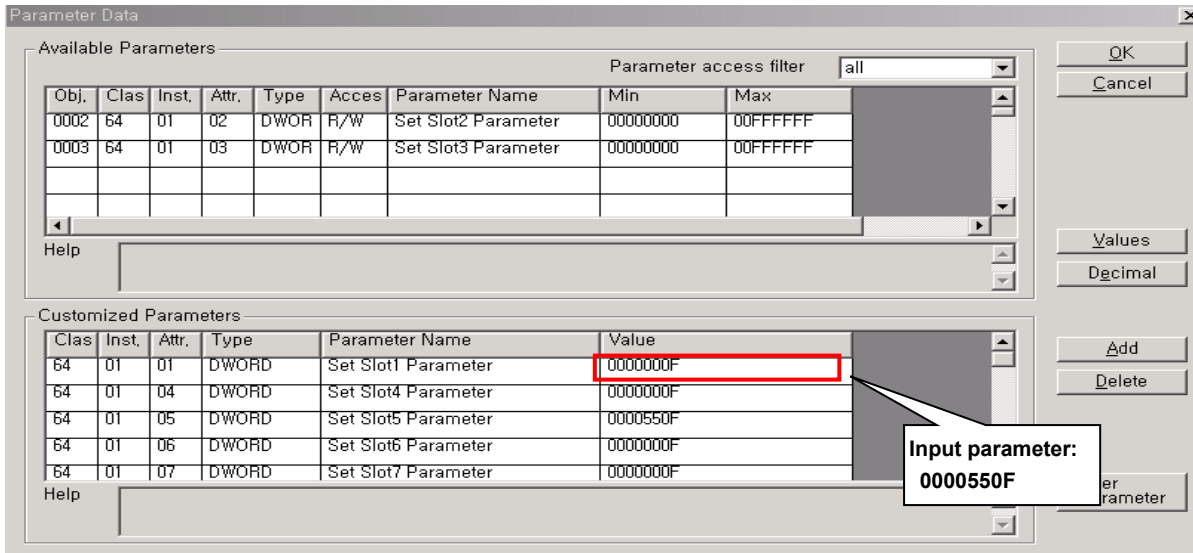

► After parameter setting is complete, download to a master module.

1) In case network is not set

After executing SyCon→Online→Download, complete through High Speed Link parameter setting of XG5000.

2) In case of changing a parameter while network setting is completed

Complete through SyCon→Online→Download->Start Communication

► Restart a DC24V power of expansion type Smart I/O Dnet

6.4.3 Example of Parameter Setting

Module	Mode	Parameter	Contents
XGF-DV04A	-	0x00 00000F	1.all channels: Enable 2.all channels voltage range: 0~10V 3.all channels data type: 0 ~ 4000
XGF-AD04A	Current	0x00 00550F	1.all channels: Enable 2.all channels input range: 0~20mA 3.all channels data type: 0 ~ 4000
XGF-AD04A	Voltage	0x00 00000F	1.all channels: Enable 2.all channels input range: 0~10V 3.all channels data type: 0 ~ 4000
XGF-RD04A	-	0x00 00000F	1.all channels: Enable 2.all channels temp. unit: Celsius 3.all channels sensor range: PT100
XGF-TC04S	-	0x00 0000FF	1.all channels: Enable 2.all channels temp. unit: Fahrenheit 3.all channels sensor type: K
XGF-AH04A	-	0x00 004444	1.all channels: Enable 2.all input channels range: 0~10V 3.all output channels range: 0~10V 4.all channels data type: 0~4000

6.5 Program Examples

6.5.1 GLOFA-GM Series

Program Example 1: Communication between Dnet modules of LSIS and other maker

This is the program that the master communication module (station 0) is installed in GM6 base slot '0' and sends/receives the data to the remote module (station 1~4) respectively. (Please refer to I/O configuration map).

System configuration

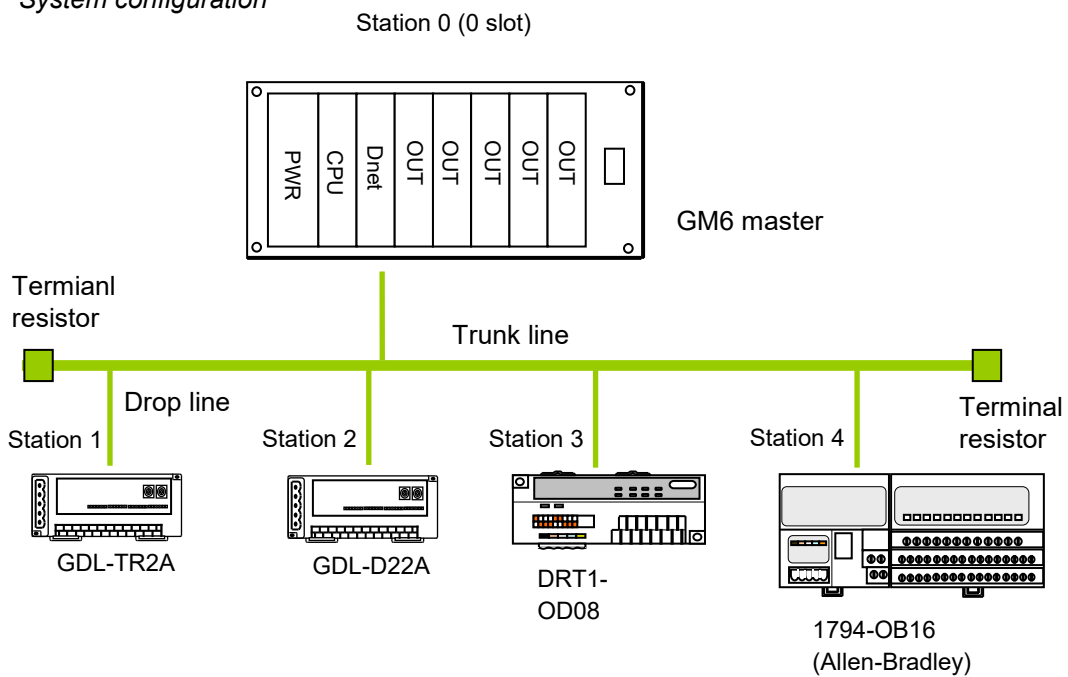

I/O configuration map

	Send/receive structure	Area to read	Storage area	Size (byte)
GM6 (Station 0) (Master)	Sending: GDL-TR2A (station 1)	%MW0	-	2
	Receiving: GDL-D22A (station 2)	-	%QW0.1.0	2
	Sending: DRT1-OD08 (station 3)	%MW100	-	1
	Sending: 1794-OB16 (station 4)	%MW200	-	4

(a) High-speed Link parameter setting in GM6 (station 0)

Master module 'link information' setting

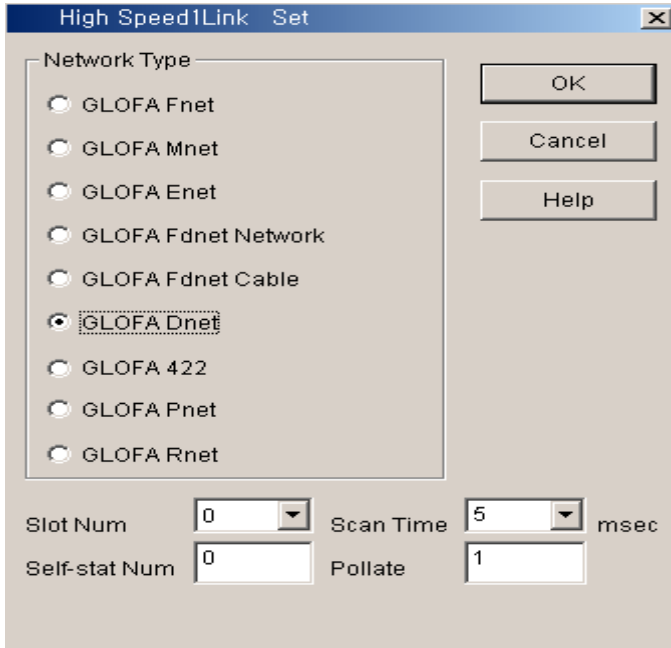

The sending parameter setting to Station 1(GDL-TR2A)

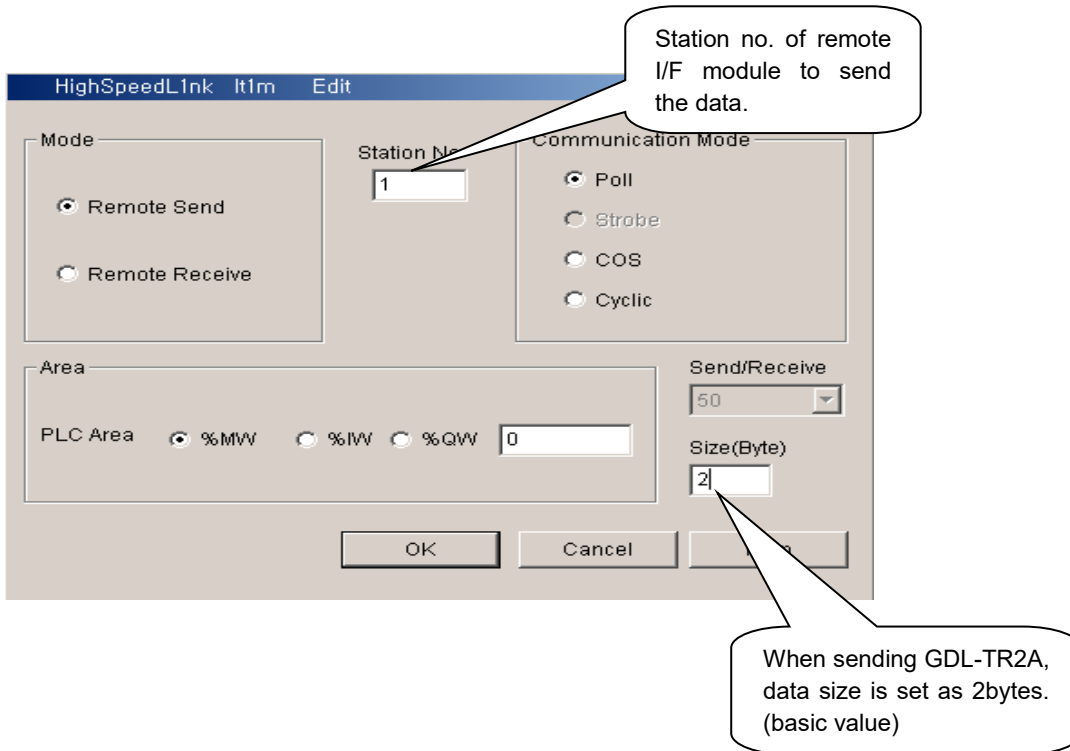

The receiving parameter setting from station 2(GDL-D22A)

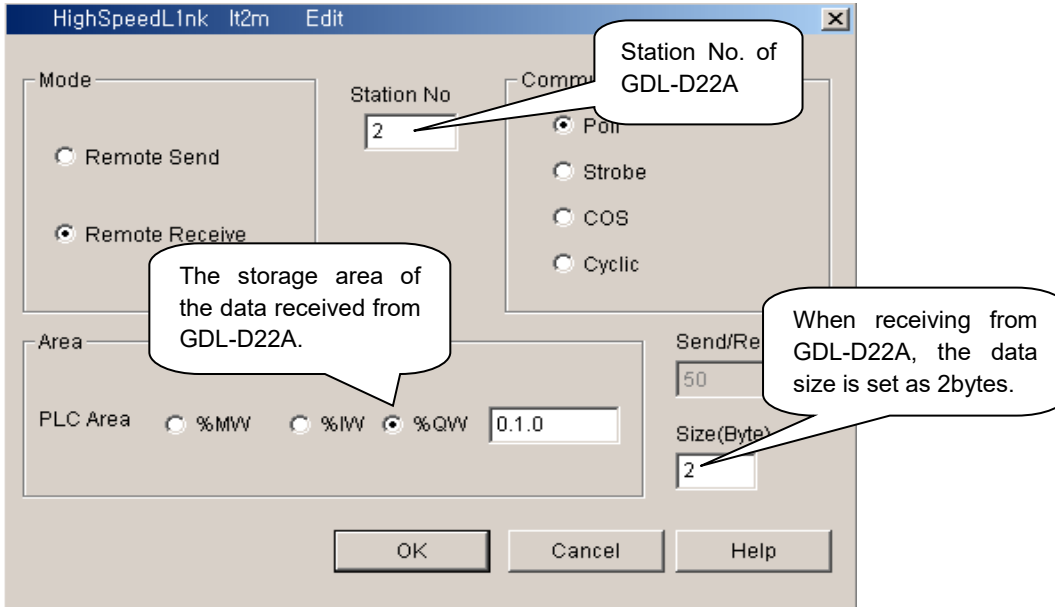

The sending parameter setting to station 3(DRT1-OD08)

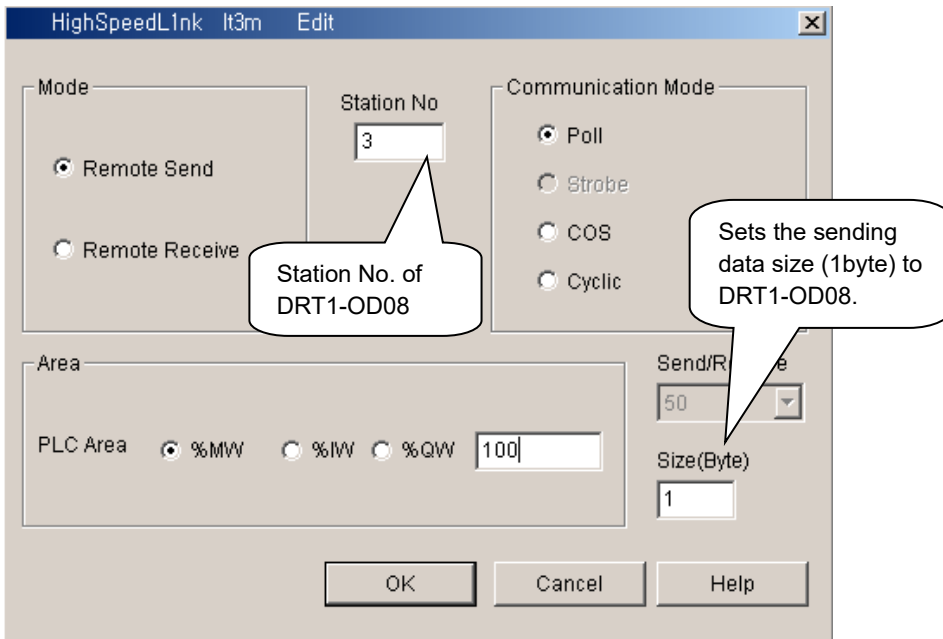

The sending parameter setting to station 4(1794-OB16)

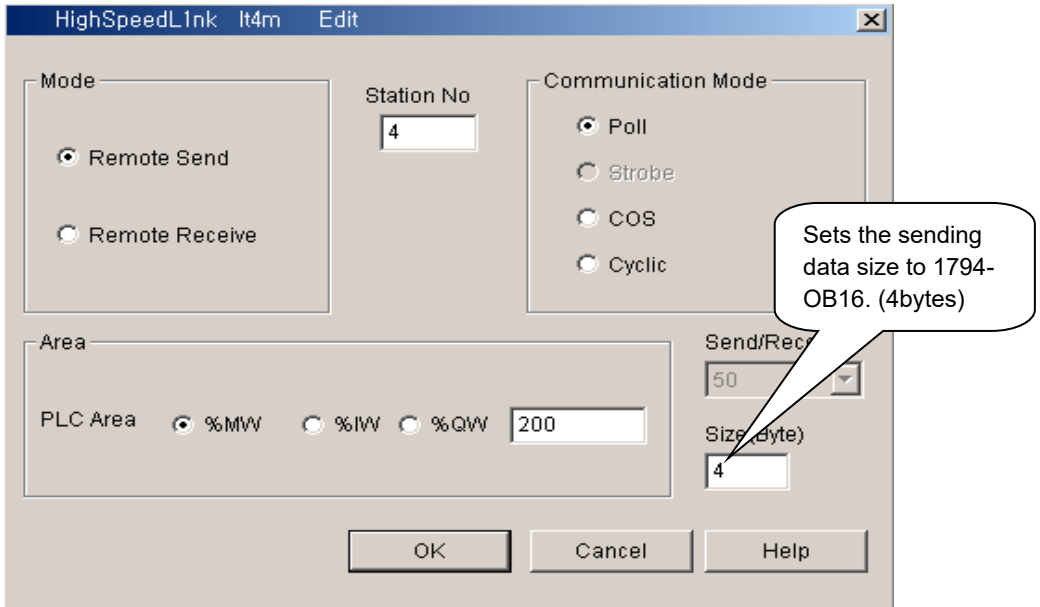

Master module 'High-speed Link 1' setting completion screen

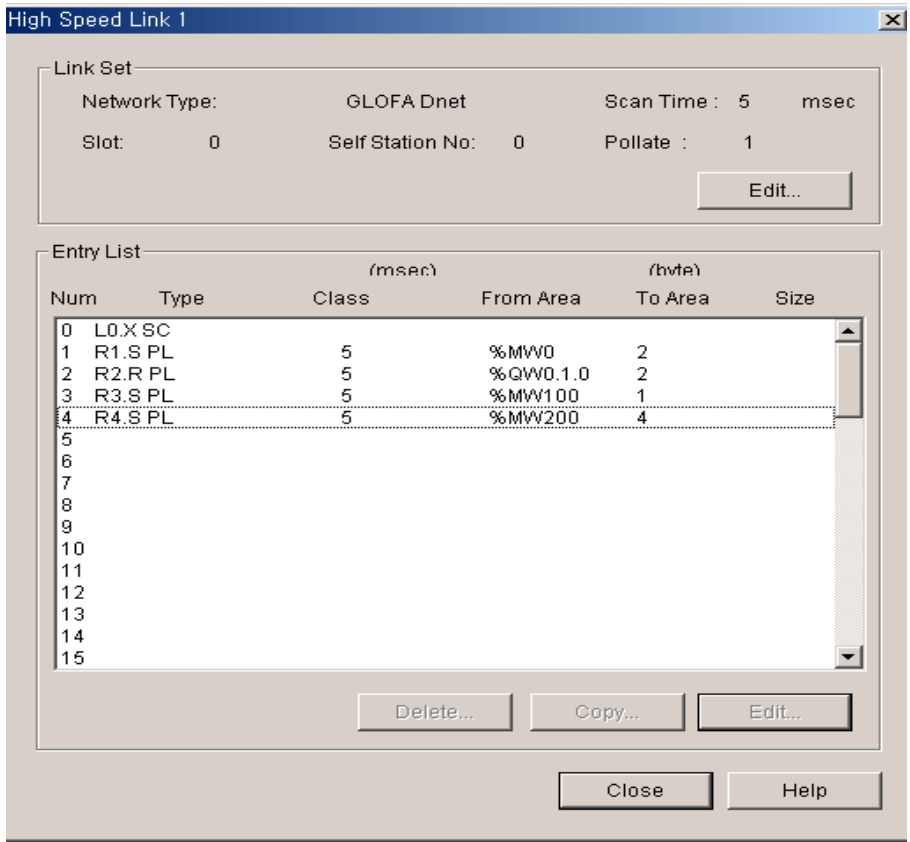

6.5.2 MASTER-K Series

Program Example - The communication between Dnet modules of LSIS

This is the program that the master communication module (station 0) is installed in K300S base slot 0 and sends/receives the data to the remote module (station 1~4) respectively. (Please refer to I/O configuration map).

System Configuration

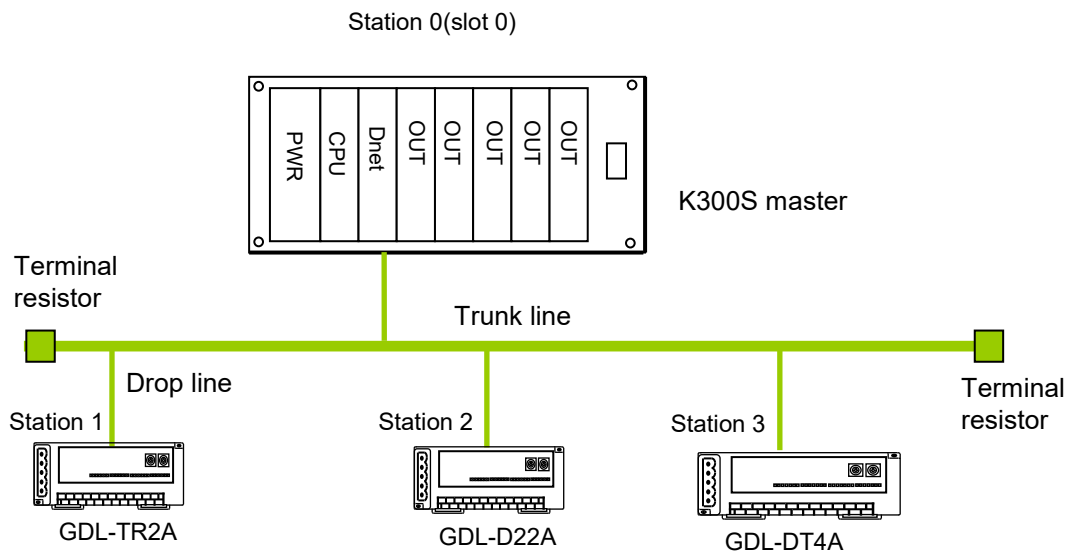

I/O configuration map

Send/receive structure		Area to read	Storage area	Size (byte)
K300S (Station 0) (Master)	Sending: GDL-TR2A (station 1)	P007	-	2
	Receiving: GDL-D22A (station 2)	-	P000	2
	Sending/receiving: GDL-DT4A (station 3)	P007	P001	2

(a) *High-speed Link* parameter setting in K300S (station 0)

To make Station 0,1,2 to change the data as specified on the table in the master configuration system, the user should write the user program first and then prepare the data sending/receiving map as shown on the table. And to send/receive the data as shown on the table, it is required to write *High-speed Link* parameter and download it in PLC and *High-speed Link* start shall be carried out according to the following order.

- 1) Station number allocation and communication cable connection
- 2) The user program writing (per station)
- 3) Makes the data sending/receiving map
- 4) Parameter setting in KGLWIN *High-speed Link* parameter setting item
- 5) Program and parameter download execution in the online menu.
- 6) Changing the mode to RUN in the online menu.
- 7) *High-speed Link* status checking through flag monitor
- 8) If the error occurs, repeat the above from 1).

High-speed Link parameter for the system of Example Program shall be set as follows.

KGLWIN parameter basic screen (in case of K300S)

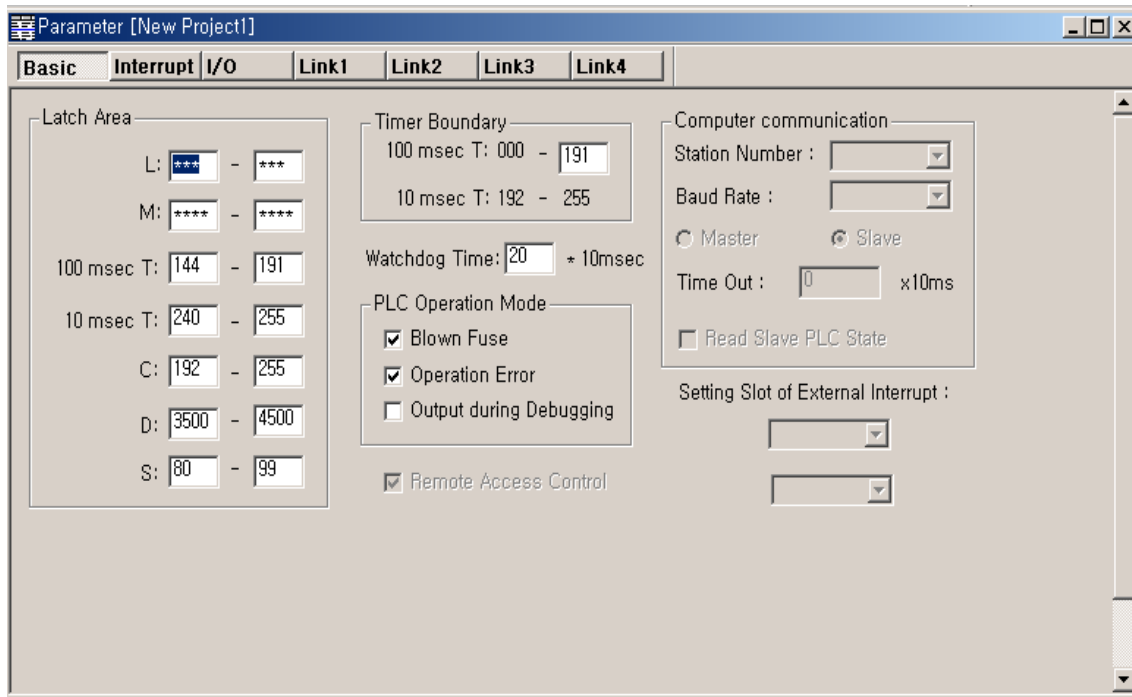

Master module 'link information' setting

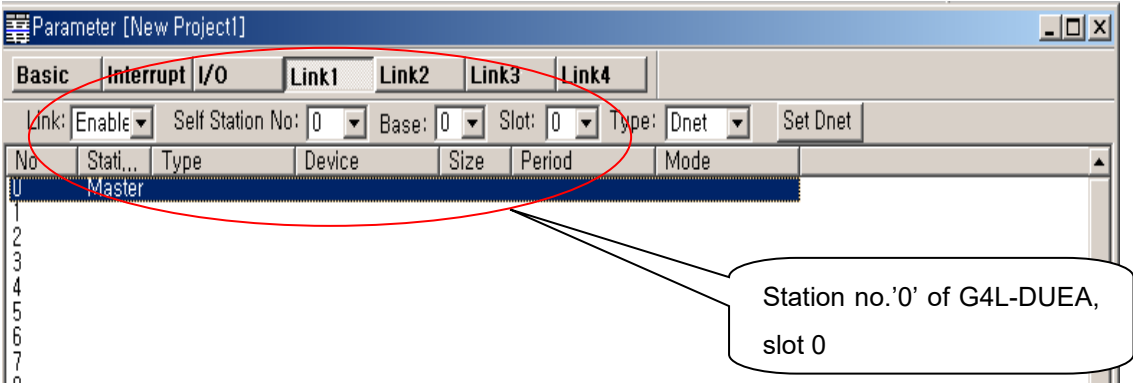

The sending parameter setting to station 1(GDL-TR2A)

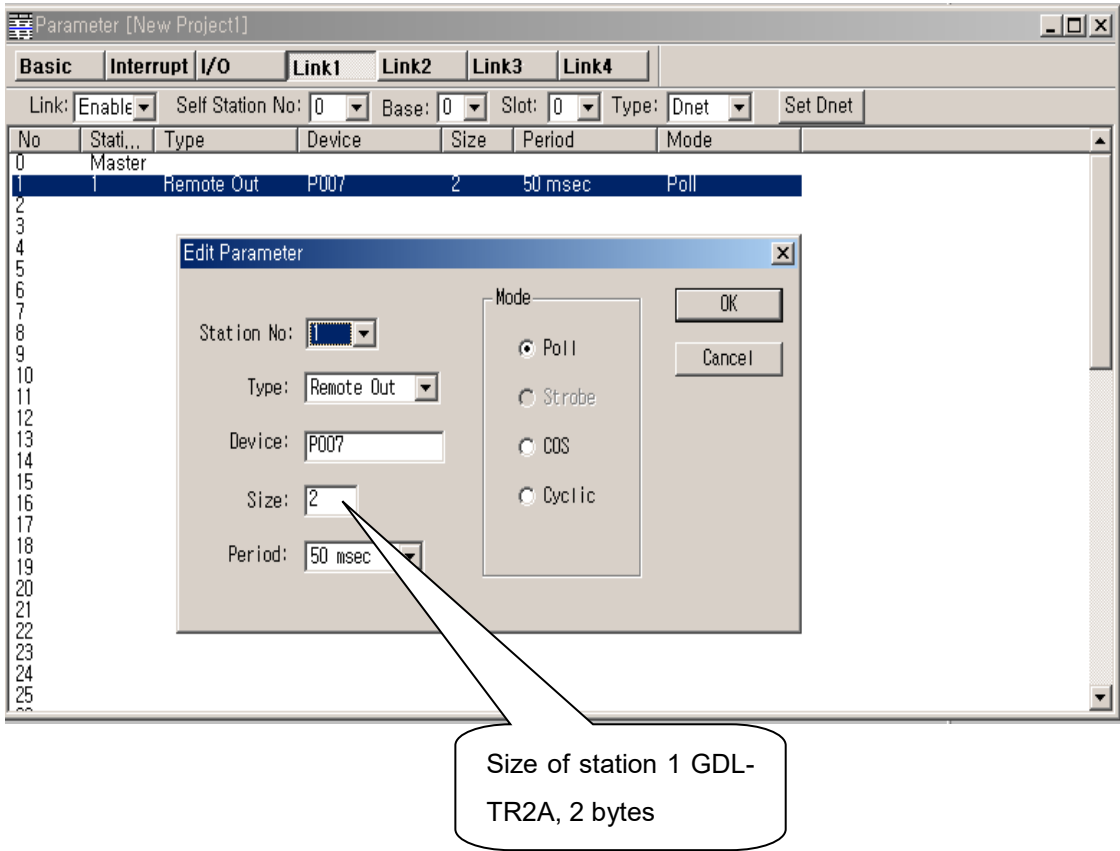

The receiving parameter setting to station 2(GDL-D22A)

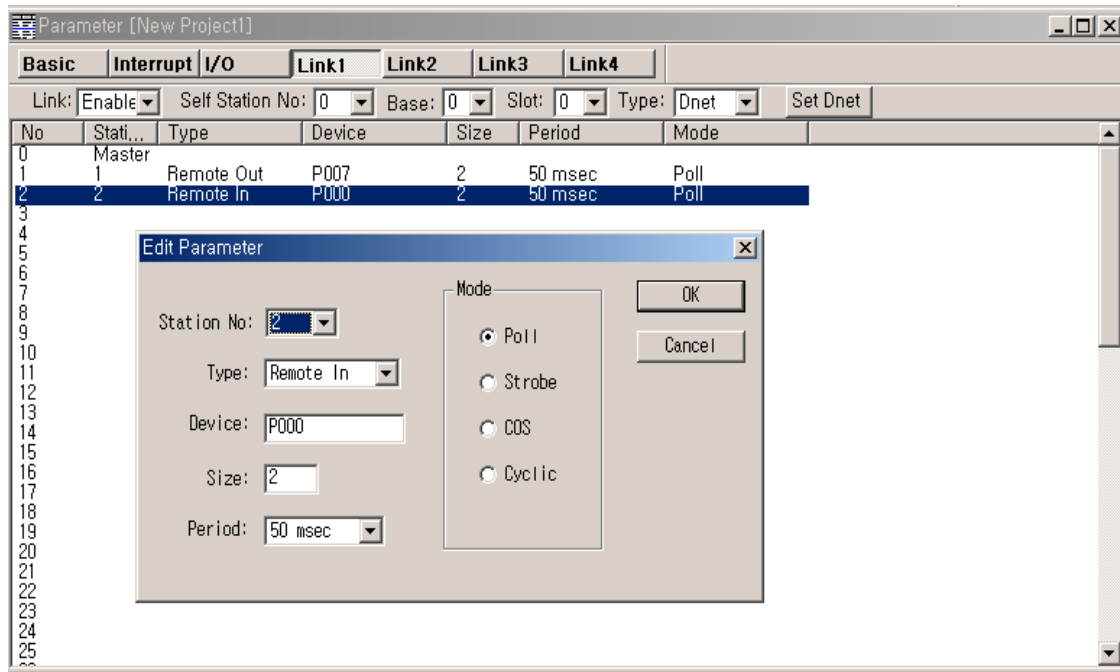

The sending parameter setting to station 3(GDL-DT4A)(combined module)

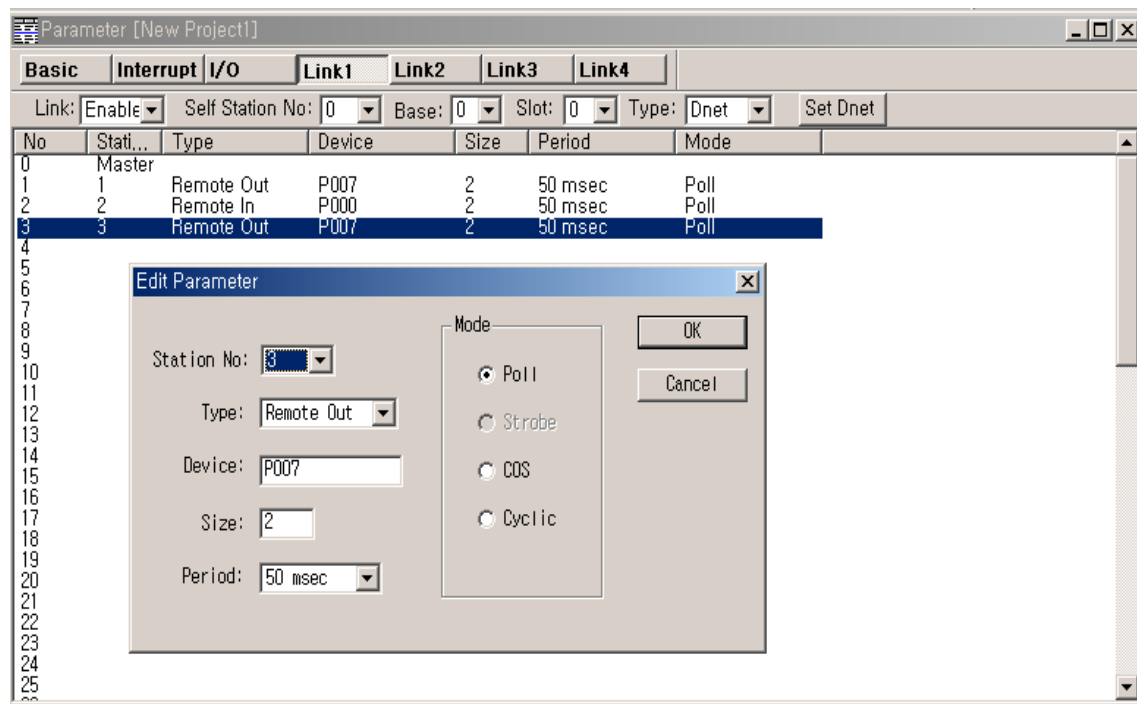

The receiving parameter setting to station 3(GDL-DT4A) (combined module)

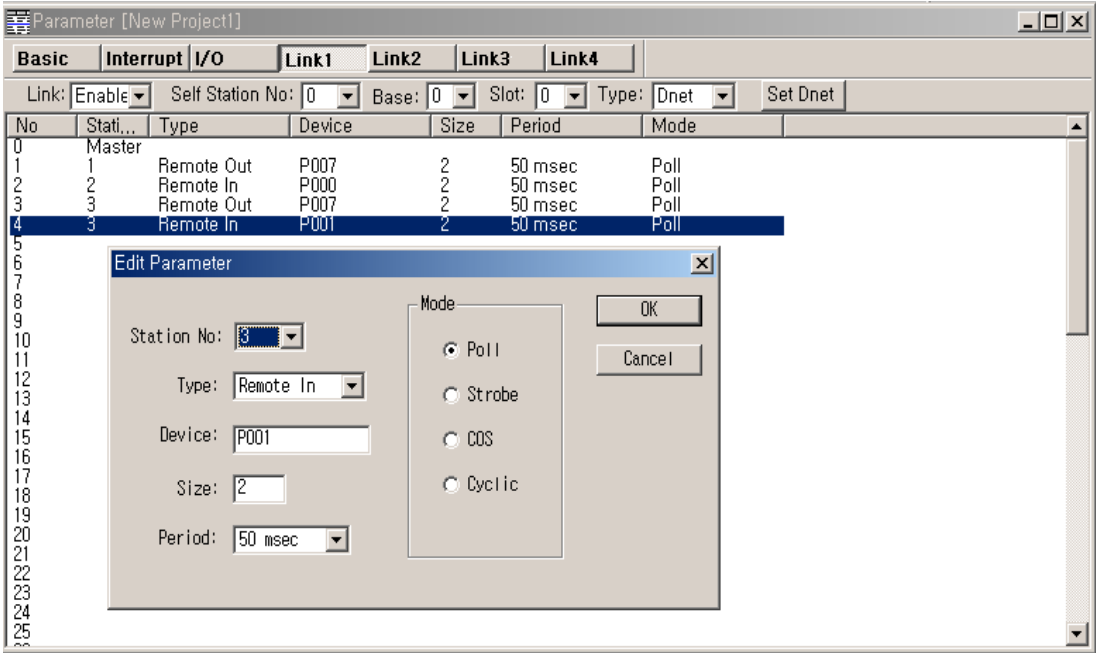

K300S High-speed Link parameter

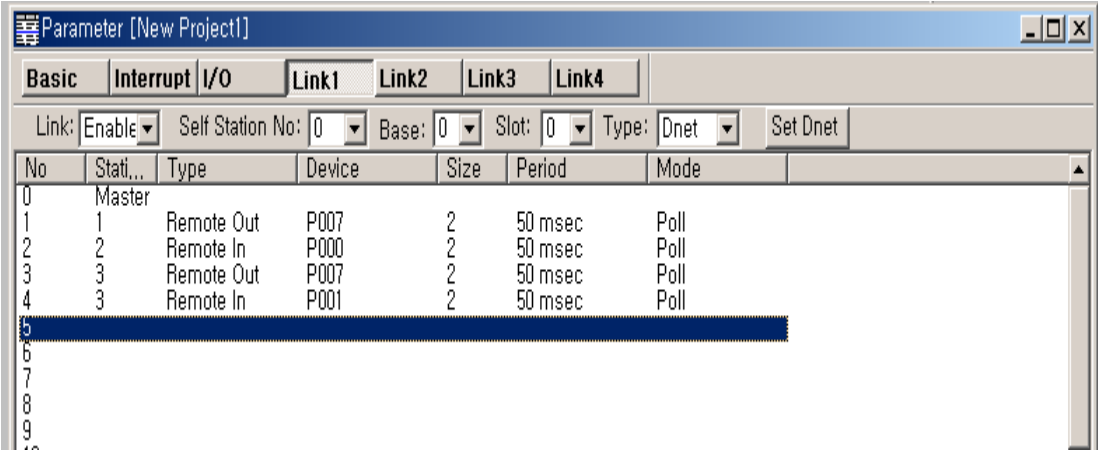

6.5.3 XGT Series

1. Program example - communication among our Smart I/O Dnet modules

Example's basic configuration and setting value is as follows.

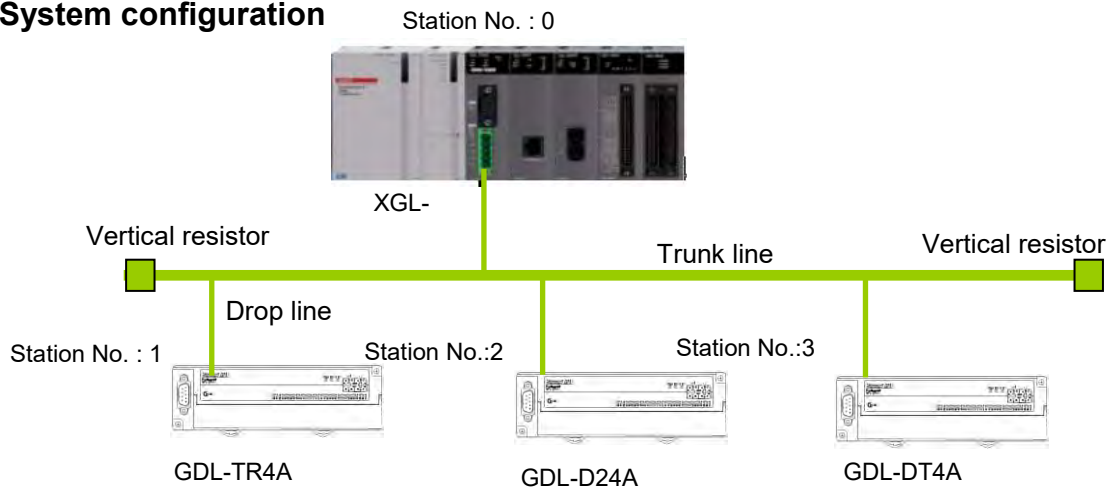

Setting category		Contents		Setting program		
System configuration	master	Master setting		XGL-DMEA	SyCon	
		Base No.		0	XG5000	
		Slot No.		0	XG5000	
		Station No.		0	SyCon	
		Communication speed		125kbps	SyCon	
		High-speed Link setting		Uses High-speed Link 1 area	XG5000	
		Communication period setting		200ms	XG5000	
	slave	Slave selection		GDL-TR4A,GDL-D24A,GDL-DT4A	SyCon	
		GDL-TR4A (Output 32 point)	Station No.		1	SyCon
			Communication method		Poll	SyCon
			Reading area		Device M100 Size 4	XG5000
		GDL-D24A (Input 32 point)	Station No.		2	SyCon
			Communication		COS	SyCon
			Storage area		Device M110 Size 4	XG5000
		GDL-DT4A Output 16point Input 16point	Station No.		3	SyCon
Communication method			COS (Transmitting period: 200ms)	SyCon		
Storage area			Device M102 Size 2	XG5000		
Reading area			Device M112 Size 2	XG5000		
Etc	Master Setting		Change of basic setting	SyCon		
	Device Assignment		communication port setting in computer	SyCon		

• System configuration

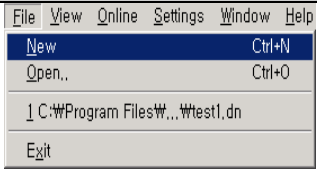
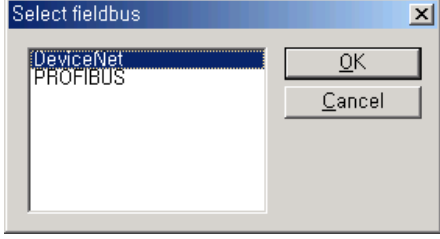

[SyCon 1 step] master and station No. setting

Menu setting: **File** → **New**

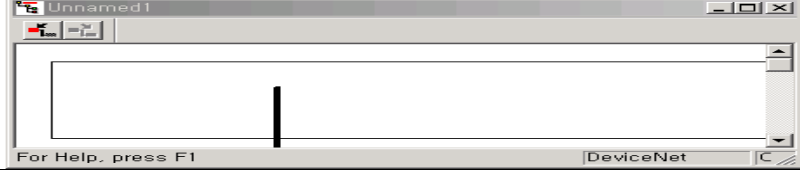
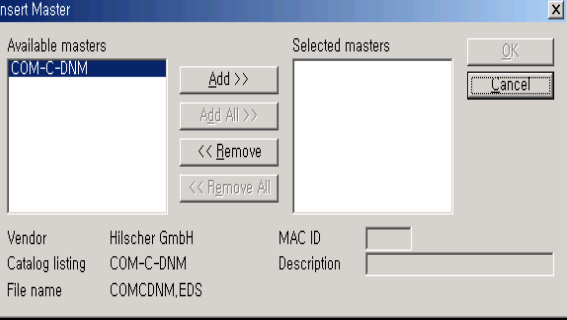
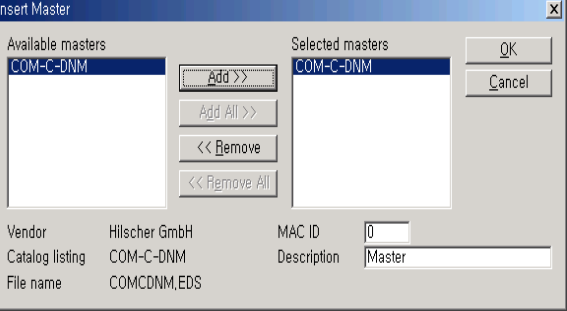
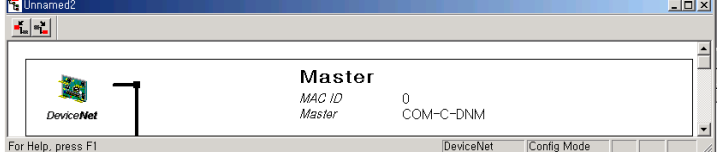
Step	Category	Screen formation and setting contents
1-1	File writing	 <p>New File writing</p>
1-2	Fieldbus selection	 <p>DeviceNet selection</p>
1-3	Master setting	<p>Recall master setting window</p> <p>Insert → Master or </p> 
1-4	Master selection	 <p>Master type selection : COM-C-DNM</p>
1-5	Station No. setting	 <p>Station No. selection: 0 Explanation-text addition: Master (Available to input only English, number)</p>
1-6	Master Setting completion	

[SyCon 2 step] Basic setting modification

Menu selection: **Settings** → **Master Settings**

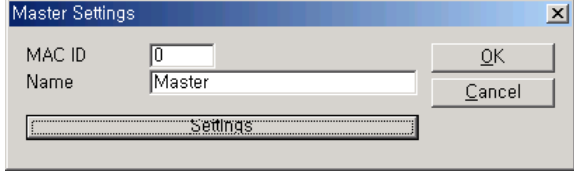
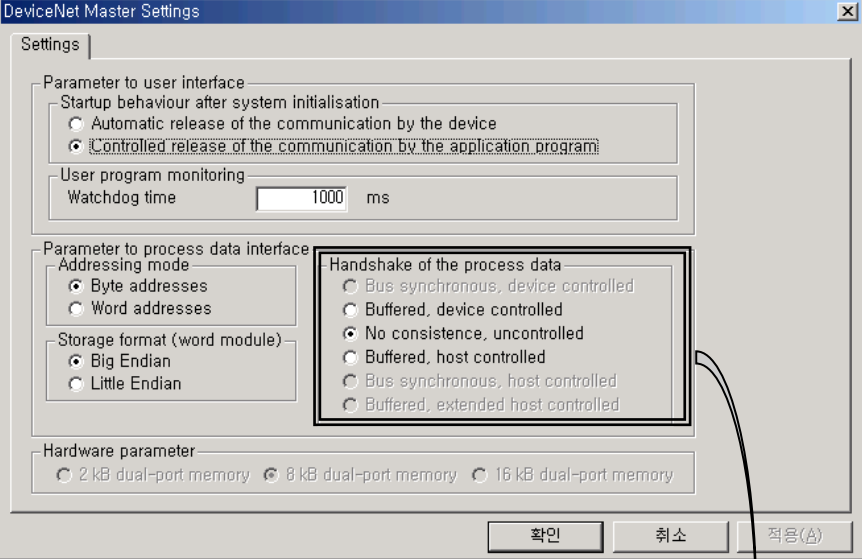
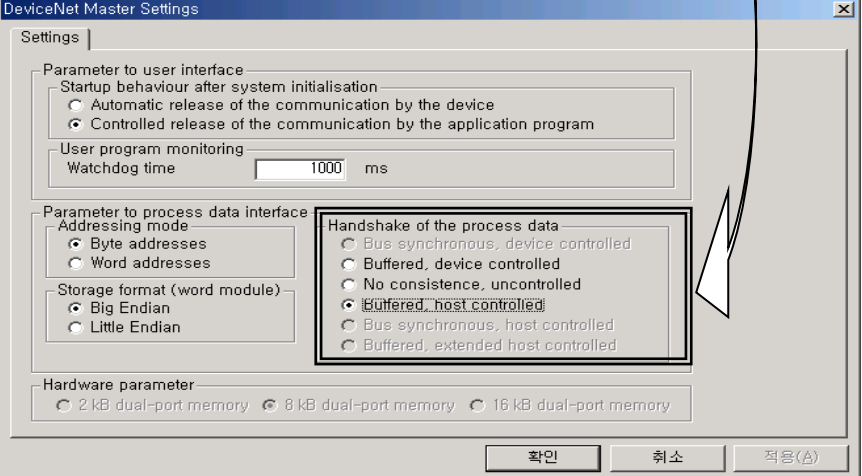
Step	Category	Screen configuration and setting contents
2-1	Master Settings	 <p>Setting of master station number: 0 Modify explanation-context: Master</p>
2-2	Basic setting	
2-3	Modification of setting value	

* Do not set except Handshake of the process data.

[SyCon 3 step] Communication speed

Menu selection: **Settings** → **Bus Parameter**

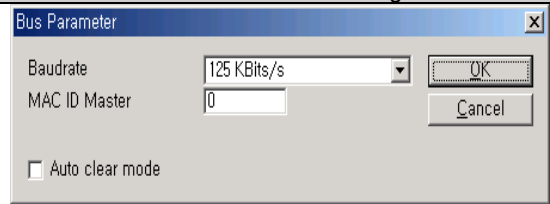
Step	Category	Screen configuration and setting contents	
3-1	Bus Parameter		Communication speed (Baudrate) :125KBit/s Setting of master station number: 0

* Auto Clear Mode

(1) When selecting

- If error occurs at slave module, it stops communicating with the entire system.
- Dnet I/F module's HS LED flicker
- Red MNS LED On

(2) When not selecting

- If error occurs at slave module, it continues communicating with normal module.

[SyCon 4 step] Setting of slave and station number

Menu selection: **Insert** → **Master**

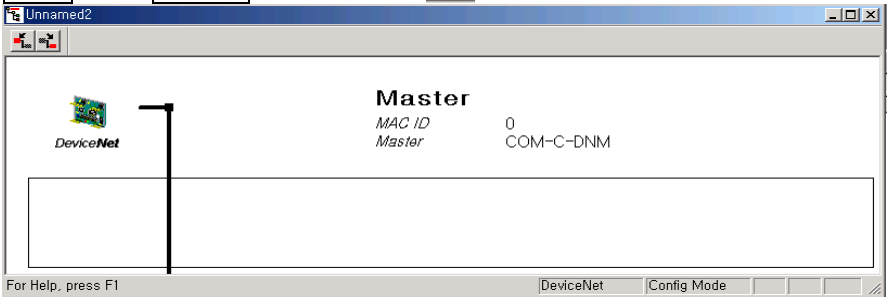
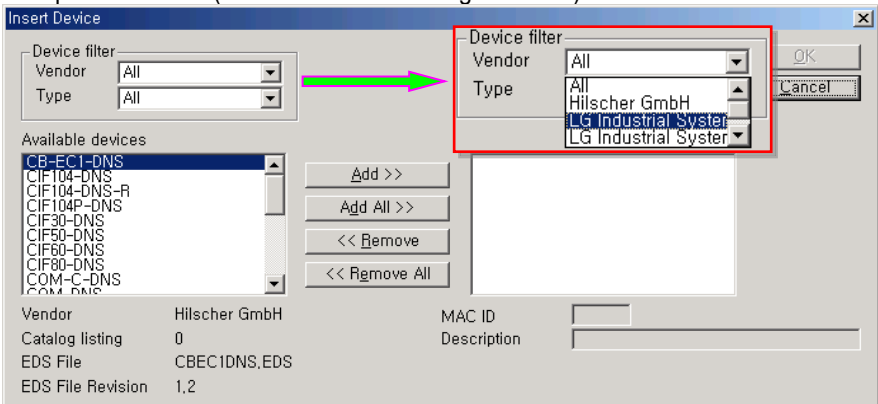
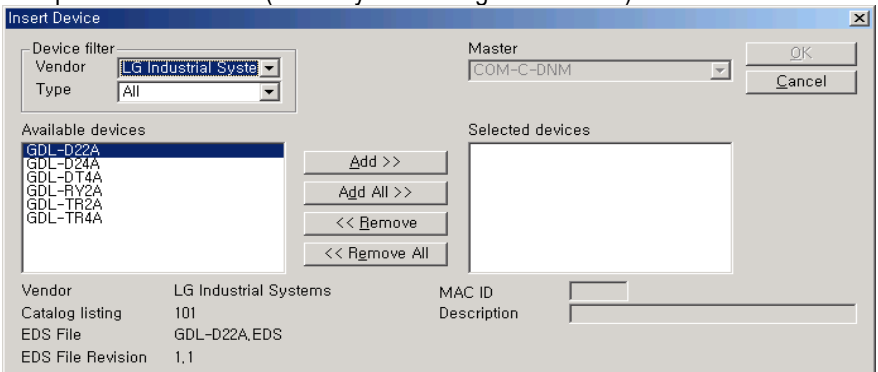
Step	Category	Screen configuration and setting contents
4-1	Slave setting	<p>Recall master setting window.</p> <p>Insert → Master or </p> 
4-2	Slave selection	<p>1 step: Device filter (Classification according to maker)</p> 
		<p>2 step: Available Device (select system configuration slave)</p> 

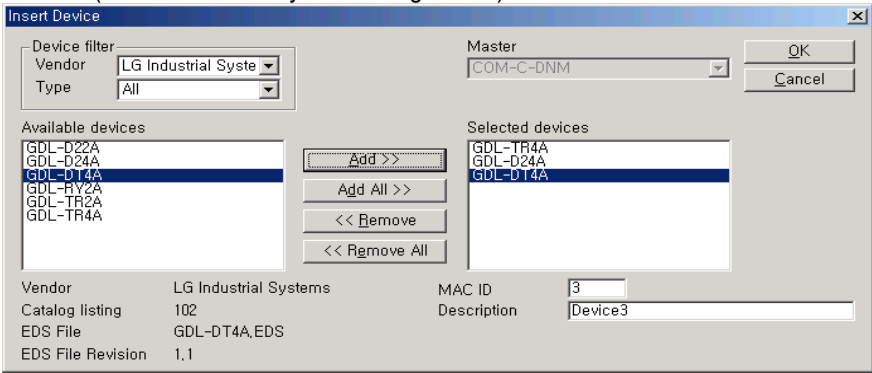
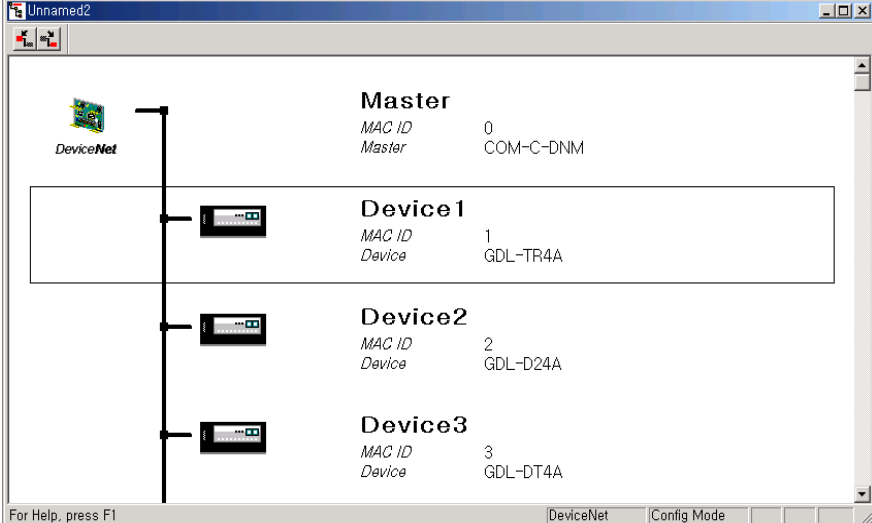
Step	Category	Screen configuration and setting contents
4-3	Station setting No.	<p>MAC ID (Set slave No. of system configuration)</p>  <p>Add explanation contexts: Device1/ Device2/ Device3</p>
4-4	Completion of slave setting	

[SyCon 5-1 Step] set the method for slave communication -slave: GDL-TR4A

Menu selection: **Settings** → **Device Configuration**

Step	Category	Screen configuration and setting contents
5-1	Setting window for slave communication method	<p>Set slave</p>
5-2	Slave station No.	<p>Set station No. (MAC ID): 1</p>
5-3	Slave communication method	<p>Select communication method: Poll</p>
5-4	Setting of Slave transmitting-receiving period	<p>Set conditions for transmitting-receiving data period and response status. →Set Poll method as a basic value.</p>
5-5	Data structure of slave (EDS File)	<p>Indicates EDS File's information(data type, I/O characteristic, data size)</p> <p>→If you select BYTE ARRAY by mouse and select Append to configured I/O data , data shows through 5-6.</p>
5-6	Data structure of slave	<p>Conveys slave structure (data type, I/O characteristic, data size) to master</p>

[SyCon 5-2 step] Setting of slave communication method - slave: GDL-D24A

Menu selection: **Settings** → **Device Configuration**

Step	category	Screen configuration and setting contents
5-1	Setting window for slave communication method	<p>Sets slave</p>
5-2	Slave station No.	<p>Set station No.(MAC ID): 2</p>
5-3	Slave communication method	<p>Select communication method: COS</p>
5-4	Setting of slave transmitting-receiving period	<p>Set conditions for transmitting/receiving period and response period of slave module. →COS Method sets Expected packet rate as 200(ms). (Setting value must be Expected packet rate > Production Inhibit time.)</p>
5-5	Slave data structure (EDS File)	<p>Indicates EDS File's information (data type, I/O characteristic, data size)</p> <p>→ If you select BYTE ARRAY by mouse and select Append to configured I/O data, data shows through 5-6.</p>
5-6	Slave data structure	<p>Conveys salve structure (data type, I/O characteristic, data size) to master</p>

[SyCon 5-3 step] Setting of slave communication method - slave: GDL-DT4A

Menu selection: **Settings** → **Device Configuration**

Step	Category	Screen configuration and setting contents
5-1	Setting window for slave communication method	<p>Sets slave</p>
5-2	Slave station No.	<p>Sets station No. (MAC ID): 3</p>
5-3	Slave communication method	<p>Select communication method: COS</p>
5-4	Setting of slave transmitting-receiving period	<p>Set conditions for transmitting-receiving period and response period of slave module. →COS Method sets Expected packet rate as 200(ms). (Setting value must be Expected packet rate > Production Inhibit time.)</p>
5-5	Slave data structure (EDS File)	<p>Indicates EDS File's information (data type, I/O characteristic, data size)</p> <p>→ If you select BYTE ARRAY by mouse and select Append to configured I/O data , data shows through 5-6.</p>
5-6	Slave data structure	<p>Conveys slave structure (data type, I/O characteristic, data size) to master</p>

[SyCon 6 step] Serial port selection

: It is same with RS-232C's wiring used in CPU module.
 So use the cable.

Menu selection: **Settings** → **Device Assignment**

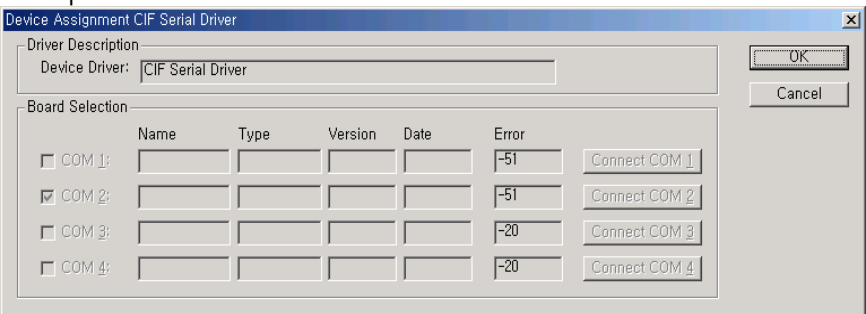
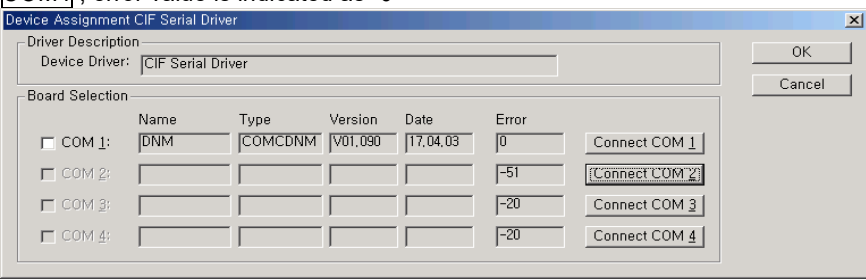
Step	Category	Screen configuration and setting contents
6-1	Setting window for serial port	<p>Serial port</p> 
6-2	Port search	<p>In activated port among Connect COM1 → Connect COM2 → Connect COM3 → Connect COM4, error value is indicated as "0"</p>  <p>Marking COM 1(<input type="checkbox"/> COM 1: → <input checked="" type="checkbox"/> COM 1:) select OK</p>

[SyCon 7 step] download

Menu selection: **Online** → **Download**

[XG50001 step] select type of CPU module

Menu selection: **OPTION** → **PLC TYPE setting**

Step	Category	Screen configuration and setting contents
1-1	CPU module selection	 <p>Select CPU module as XGK-CPUS</p>

[XG5000 2 step] Communication method setting

Menu selection: **Online** → **Connection Setting**

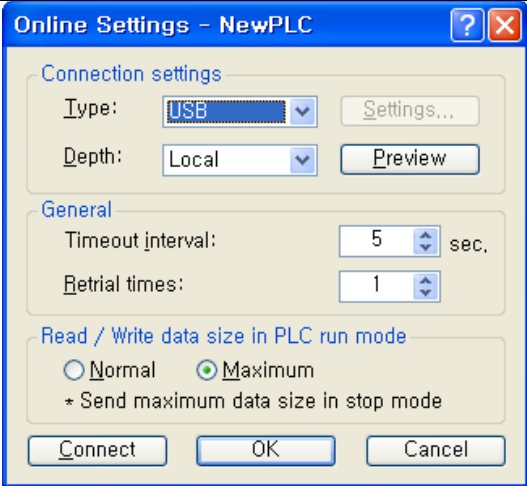
Step	Category	Screen configuration and setting contents
2-1	Communication method setting	 <p>Connecting method: USB Connecting step: local</p>

[XG5000 3 step] connection

Menu selection: **Online** → **Connection**

[XG5000 4 step] I/O information reading

Menu selection: [Online]-[Diagnosis]-[I/O Information]-[I/O Sync]

[XG5000 5 step] High-speed Link setting

Menu selection: parameter → High-speed Link (HS Link) → High-speed Link 1

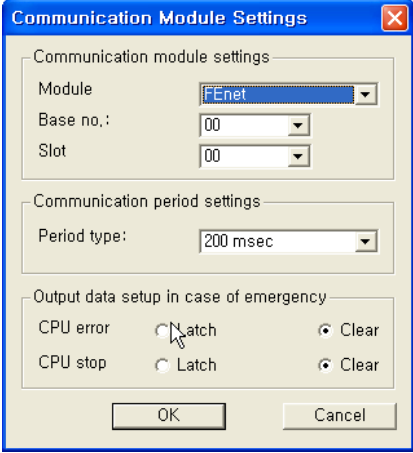
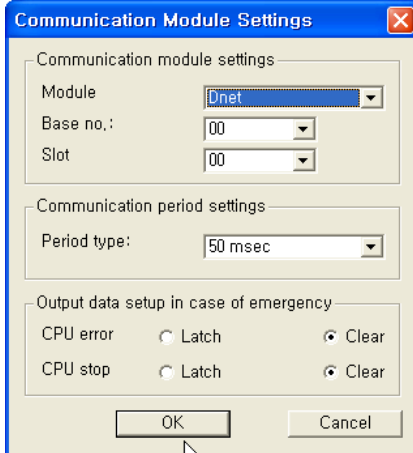
Step	Category	Screen configuration and setting contents
		<p>Initial screen</p> 
5-1	Communication module setting	<p>set Dnet I/F module in High-speed Link</p>  <p>Module type: Dnet Base No.: 00 Slot No.: 00</p> <p>Communication period setting: 200ms</p>

[XG5000 6-1 Step] SyCon upload

Menu selection: [Online]-[Communication module setting]-[SyCon upload (Pnet, Dnet)]

Step	Category	Screen configuration and setting contents																																														
6-1	Communication module setting	<p>Initial screen</p>																																														
		<p>Select index in the block window</p>																																														
		<p>SyCon upload</p> <table border="1"> <thead> <tr> <th>Index</th> <th>Mode</th> <th>Station number</th> <th>Communication method</th> <th>Read area</th> <th>Sending data (Byte)</th> <th>Save area</th> <th>Receiving data (Byte)</th> </tr> </thead> <tbody> <tr> <td>0</td> <td>send</td> <td>1</td> <td>Poll</td> <td></td> <td>4</td> <td></td> <td></td> </tr> <tr> <td>1</td> <td>receive</td> <td>2</td> <td>COS</td> <td></td> <td></td> <td></td> <td>4</td> </tr> <tr> <td>2</td> <td>send/receive</td> <td>3</td> <td>COS</td> <td></td> <td>2</td> <td></td> <td>2</td> </tr> <tr> <td>3</td> <td></td> <td></td> <td></td> <td></td> <td></td> <td></td> <td></td> </tr> <tr> <td>4</td> <td></td> <td></td> <td></td> <td></td> <td></td> <td></td> <td></td> </tr> </tbody> </table>	Index	Mode	Station number	Communication method	Read area	Sending data (Byte)	Save area	Receiving data (Byte)	0	send	1	Poll		4			1	receive	2	COS				4	2	send/receive	3	COS		2		2	3								4					
Index	Mode	Station number	Communication method	Read area	Sending data (Byte)	Save area	Receiving data (Byte)																																									
0	send	1	Poll		4																																											
1	receive	2	COS				4																																									
2	send/receive	3	COS		2		2																																									
3																																																
4																																																

[XG5000 6-2 step] Reading area/storage area setting

Menu selection: parameter → High-speed Link (HS Link) → High-speed Link 1 → Block

Step	Category	Screen configuration and setting contents																																																
6-2	Communication module setting	<p>Initial screen</p> <table border="1"> <thead> <tr> <th>Index</th> <th>Mode</th> <th>Station number</th> <th>Communication method</th> <th>Read area</th> <th>Sending data (Byte)</th> <th>Save area</th> <th>Receiving data (Byte)</th> </tr> </thead> <tbody> <tr> <td>0</td> <td>send</td> <td>1</td> <td>Poll</td> <td></td> <td>4</td> <td></td> <td></td> </tr> <tr> <td>1</td> <td>receive</td> <td>2</td> <td>COS</td> <td></td> <td></td> <td></td> <td>4</td> </tr> <tr> <td>2</td> <td>send/receive</td> <td>3</td> <td>COS</td> <td></td> <td>2</td> <td></td> <td>2</td> </tr> <tr> <td>3</td> <td></td> <td></td> <td></td> <td></td> <td></td> <td></td> <td></td> </tr> <tr> <td>4</td> <td></td> <td></td> <td></td> <td></td> <td></td> <td></td> <td></td> </tr> </tbody> </table>	Index	Mode	Station number	Communication method	Read area	Sending data (Byte)	Save area	Receiving data (Byte)	0	send	1	Poll		4			1	receive	2	COS				4	2	send/receive	3	COS		2		2	3								4							
		Index	Mode	Station number	Communication method	Read area	Sending data (Byte)	Save area	Receiving data (Byte)																																									
		0	send	1	Poll		4																																											
		1	receive	2	COS				4																																									
		2	send/receive	3	COS		2		2																																									
3																																																		
4																																																		
Index selection in Block window.																																																		
Slave module	Index	High-speed Link block setting																																																
GDL-TR4A	0	<table border="1"> <thead> <tr> <th>Index</th> <th>Mode</th> <th>Station number</th> <th>Communication method</th> <th>Read area</th> <th>Sending data (Byte)</th> <th>Save area</th> <th>Receiving data (Byte)</th> </tr> </thead> <tbody> <tr> <td>0</td> <td>send</td> <td>1</td> <td>Poll</td> <td>M0100</td> <td>4</td> <td></td> <td></td> </tr> <tr> <td>1</td> <td>receive</td> <td>2</td> <td>COS</td> <td></td> <td></td> <td></td> <td>4</td> </tr> <tr> <td>2</td> <td>send/receive</td> <td>3</td> <td>COS</td> <td></td> <td>2</td> <td></td> <td>2</td> </tr> <tr> <td>3</td> <td></td> <td></td> <td></td> <td></td> <td></td> <td></td> <td></td> </tr> <tr> <td>4</td> <td></td> <td></td> <td></td> <td></td> <td></td> <td></td> <td></td> </tr> </tbody> </table>	Index	Mode	Station number	Communication method	Read area	Sending data (Byte)	Save area	Receiving data (Byte)	0	send	1	Poll	M0100	4			1	receive	2	COS				4	2	send/receive	3	COS		2		2	3								4							
Index	Mode	Station number	Communication method	Read area	Sending data (Byte)	Save area	Receiving data (Byte)																																											
0	send	1	Poll	M0100	4																																													
1	receive	2	COS				4																																											
2	send/receive	3	COS		2		2																																											
3																																																		
4																																																		
GDL-D24A	1	<table border="1"> <thead> <tr> <th>Index</th> <th>Mode</th> <th>Station number</th> <th>Communication method</th> <th>Read area</th> <th>Sending data (Byte)</th> <th>Save area</th> <th>Receiving data (Byte)</th> </tr> </thead> <tbody> <tr> <td>0</td> <td>send</td> <td>1</td> <td>Poll</td> <td>M0100</td> <td>4</td> <td></td> <td></td> </tr> <tr> <td>1</td> <td>receive</td> <td>2</td> <td>COS</td> <td></td> <td></td> <td>M0110</td> <td>4</td> </tr> <tr> <td>2</td> <td>send/receive</td> <td>3</td> <td>COS</td> <td></td> <td>2</td> <td></td> <td>2</td> </tr> <tr> <td>3</td> <td></td> <td></td> <td></td> <td></td> <td></td> <td></td> <td></td> </tr> <tr> <td>4</td> <td></td> <td></td> <td></td> <td></td> <td></td> <td></td> <td></td> </tr> </tbody> </table>	Index	Mode	Station number	Communication method	Read area	Sending data (Byte)	Save area	Receiving data (Byte)	0	send	1	Poll	M0100	4			1	receive	2	COS			M0110	4	2	send/receive	3	COS		2		2	3								4							
Index	Mode	Station number	Communication method	Read area	Sending data (Byte)	Save area	Receiving data (Byte)																																											
0	send	1	Poll	M0100	4																																													
1	receive	2	COS			M0110	4																																											
2	send/receive	3	COS		2		2																																											
3																																																		
4																																																		
GDL-DT4A	2	<table border="1"> <thead> <tr> <th>Index</th> <th>Mode</th> <th>Station number</th> <th>Communication method</th> <th>Read area</th> <th>Sending data (Byte)</th> <th>Save area</th> <th>Receiving data (Byte)</th> </tr> </thead> <tbody> <tr> <td>0</td> <td>send</td> <td>1</td> <td>Poll</td> <td>M0100</td> <td>4</td> <td></td> <td></td> </tr> <tr> <td>1</td> <td>receive</td> <td>2</td> <td>COS</td> <td></td> <td></td> <td>M0110</td> <td>4</td> </tr> <tr> <td>2</td> <td>send/receive</td> <td>3</td> <td>COS</td> <td>M0102</td> <td>2</td> <td>M0112</td> <td>2</td> </tr> <tr> <td>3</td> <td></td> <td></td> <td></td> <td></td> <td></td> <td></td> <td></td> </tr> <tr> <td>4</td> <td></td> <td></td> <td></td> <td></td> <td></td> <td></td> <td></td> </tr> </tbody> </table>	Index	Mode	Station number	Communication method	Read area	Sending data (Byte)	Save area	Receiving data (Byte)	0	send	1	Poll	M0100	4			1	receive	2	COS			M0110	4	2	send/receive	3	COS	M0102	2	M0112	2	3								4							
Index	Mode	Station number	Communication method	Read area	Sending data (Byte)	Save area	Receiving data (Byte)																																											
0	send	1	Poll	M0100	4																																													
1	receive	2	COS			M0110	4																																											
2	send/receive	3	COS	M0102	2	M0112	2																																											
3																																																		
4																																																		
High-speed Link block after setting reading area/storage area	<table border="1"> <thead> <tr> <th>Index</th> <th>Mode</th> <th>Station number</th> <th>Communication method</th> <th>Read area</th> <th>Sending data (Byte)</th> <th>Save area</th> <th>Receiving data (Byte)</th> </tr> </thead> <tbody> <tr> <td>0</td> <td>send</td> <td>1</td> <td>Poll</td> <td>M0100</td> <td>4</td> <td></td> <td></td> </tr> <tr> <td>1</td> <td>receive</td> <td>2</td> <td>COS</td> <td></td> <td></td> <td>M0110</td> <td>4</td> </tr> <tr> <td>2</td> <td>send/receive</td> <td>3</td> <td>COS</td> <td>M0102</td> <td>2</td> <td>M0112</td> <td>2</td> </tr> <tr> <td>3</td> <td></td> <td></td> <td></td> <td></td> <td></td> <td></td> <td></td> </tr> <tr> <td>4</td> <td></td> <td></td> <td></td> <td></td> <td></td> <td></td> <td></td> </tr> </tbody> </table>	Index	Mode	Station number	Communication method	Read area	Sending data (Byte)	Save area	Receiving data (Byte)	0	send	1	Poll	M0100	4			1	receive	2	COS			M0110	4	2	send/receive	3	COS	M0102	2	M0112	2	3								4								
Index	Mode	Station number	Communication method	Read area	Sending data (Byte)	Save area	Receiving data (Byte)																																											
0	send	1	Poll	M0100	4																																													
1	receive	2	COS			M0110	4																																											
2	send/receive	3	COS	M0102	2	M0112	2																																											
3																																																		
4																																																		

[XG5000 7 Step] High-speed Link parameter writing

Menu selection: [Online]-[Write]

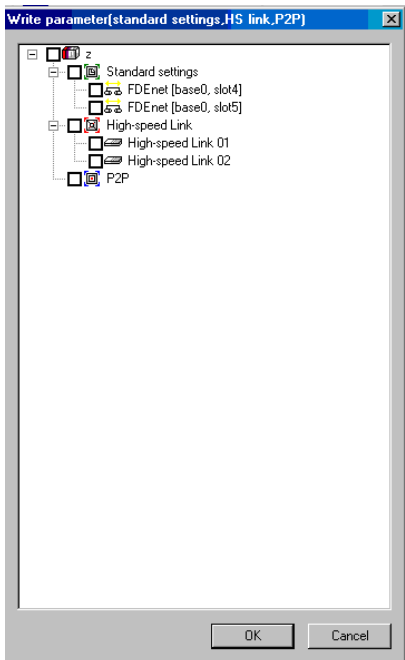
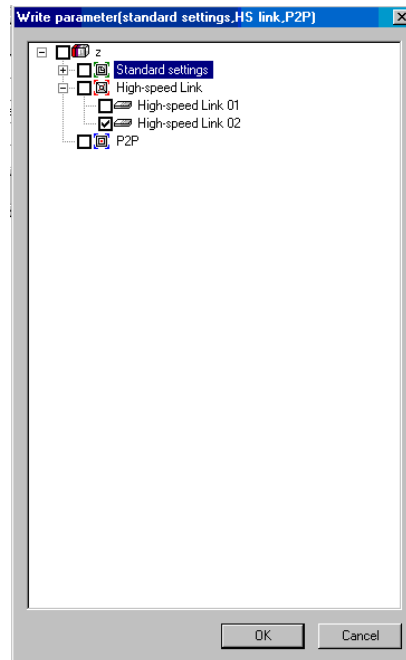
Step	Category	Screen configuration and setting contents	
7-1	Parameter writing	Initial screen	High-speed Link selection
			
		Pressing [OK], parameter is downloaded.	

- The data of parameter writing is stored in CPU module.
-So you should back up High-speed Link parameter when changing CPU module.

[XG5000 8 step] High-speed Link enable

Menu selection: [Online]-[Communication module setting]-[Enable link(HS Link, P2P)]

→ Communication between master module and slave module is allowed.

(2) Program example - Communication between our extension type Smart I/O Pnet

The basic configuration and setting value is as follows.

Setting category		Contents		Setting program	
System configuration	Master	Master setting		XGL-PMEA	SyCon
		Base No.		0	XG5000
		Slot No.		0	XG5000
		Station No.		0	SyCon
		Communication speed		1.5Mbps	SyCon
		HSL setting		Use HSL 1	XG5000
	Communication period setting		200ms	XG5000	
	Slave	Slave selection		XPL-BSSA	SyCon
		XDL-BSSA (XBE-TN32A:Tr out XBE-RY16A:Relay out XBE-DC32A:DC input XBF-AD04A:A/D conversion module XBE-DV04A:D/A conversion module	Station No.	3	SyCon
			Reading area	Device	P1000
Size		14			
Storage area		Device	M200	XG5000	
		Size	12		
ETC	Master Setting		Basic setting value modification	SyCon	
	Device Assignment		PC's communication port setting	SyCon	



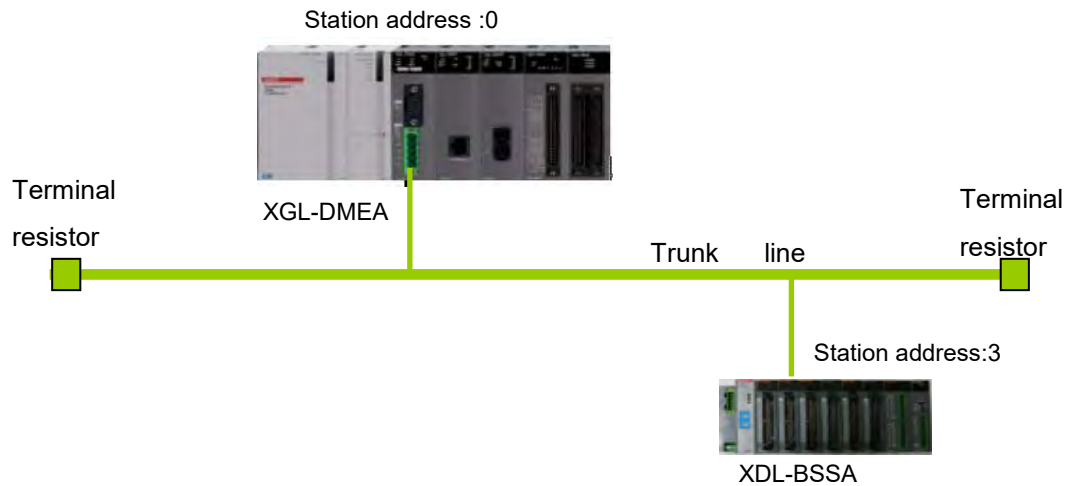

• System configuration

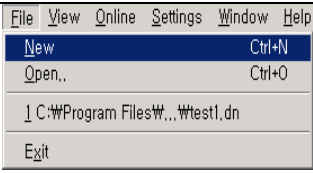
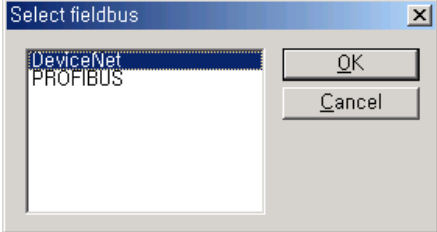

Slot location	1	2	3	4	5
Name	XBE-TN32A	XBE-RY16A	XBE-DC32A	XBF-AD04A	XBE-DV04A
Content	Tr out	Relay out	DC input	A/D conversion input module	D/A conversion output module
I/O data size	32 point (4 byte)	16 point (2 byte)	32 point (4 byte)	64 point (8 byte)	64 point (8byte)

[SyCon 1 step] master and station No. setting

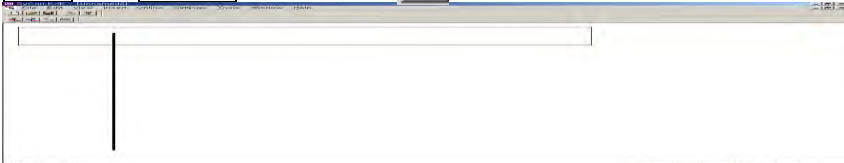
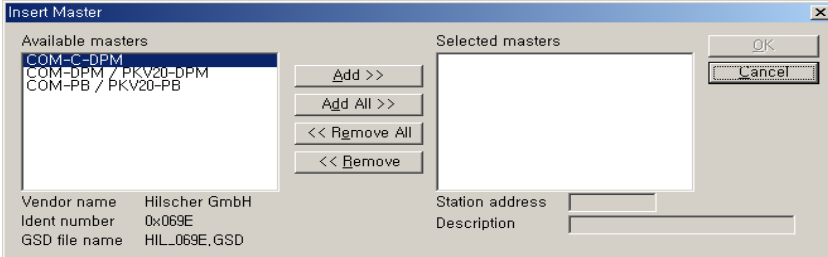
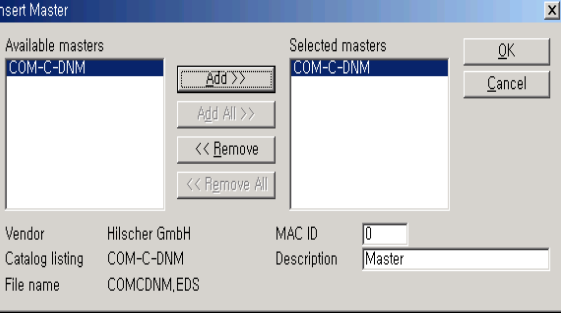
Menu setting : **File** → **New**

Step	Category	Screen formation and setting contents
1-1	File writing	 <p>New File writing</p>
1-2	Fieldbus selection	 <p>PROFIBUS selection</p>
1-3	Master setting	<p>Recall master setting window</p> <p>Insert → master or </p> 
1-4	Master selection	<p>Master type selection: COM-C-DNM</p> 
1-5	Station setting	<p>No.</p>  <p>Station No. selection: 0</p> <p>Explanation-text addition: Master (Available to input only English, number)</p>
1-6	Master Setting completion	 <p>Master0 Station address 0 DP Master COM-C-DPM</p>

[SyCon 2 step] basic setting modification

Menu selection: **Settings** → **Master Settings**

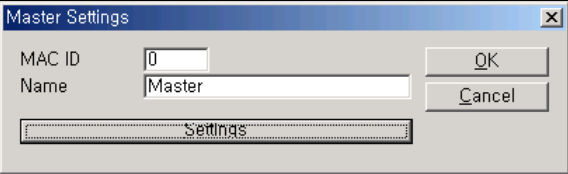
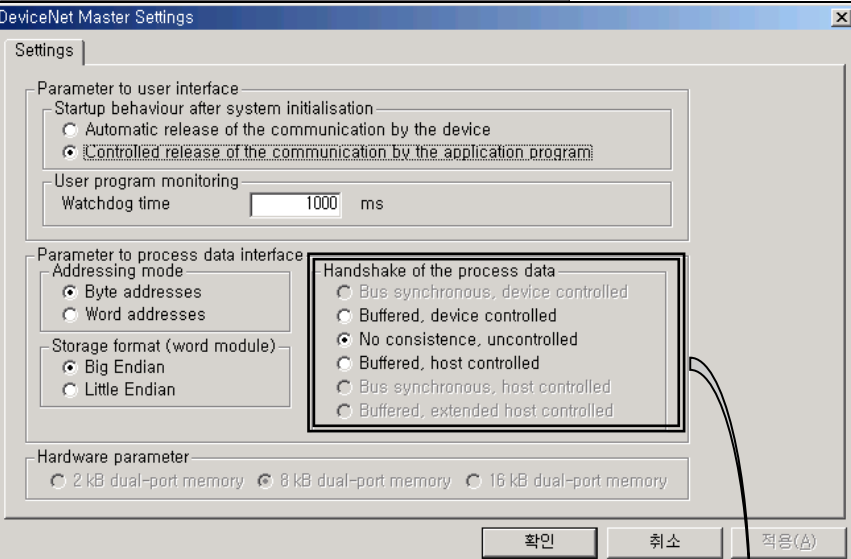
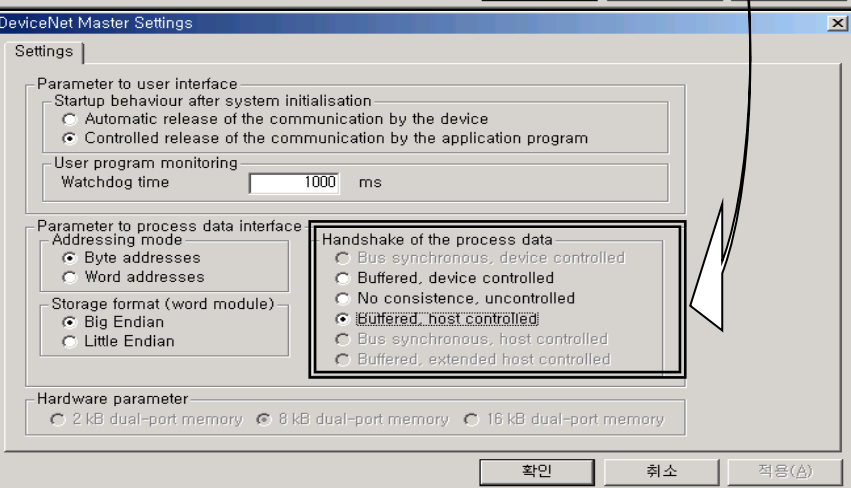
Step	Category	Screen configuration and setting contents
2-1	Master Settings	 <p>master station address: 0 name modification: Master</p>
2-2	Basic setting	
2-3	Setting value modification	

* Do not change default value except 'Handshake of the process data'

[SyCon 3 step] communication speed

Menu selection: **Settings** → **Bus Parameter**

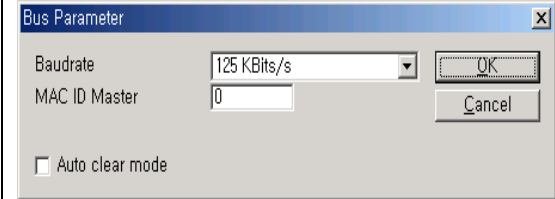
Step	Category	Screen configuration and setting contents	
3-1	Bus Parameter		Baudrate:125KBit/s Master station address setting : 0

* Auto Clear Mode

(1) When selecting it

- If error occurs in some slave module, stop all communication with normal slave module.
- Dnet I/F module's HS LED red color flicker
MNS LED red color flicker

(2) When not selecting it

- If error occurs in some slave module, continue communication with normal slave module.

[SyCon 4 step] Setting of slave and station number

Menu selection: **Insert** → **Master**

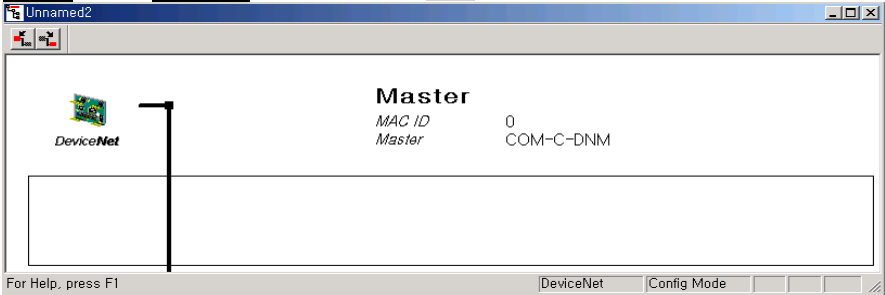
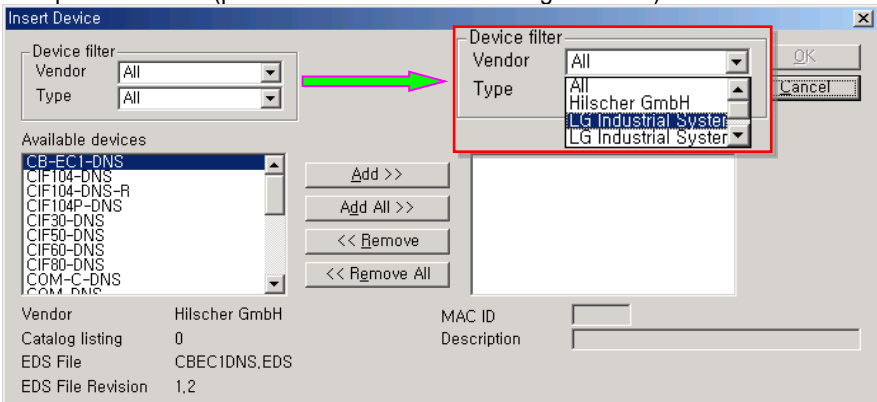
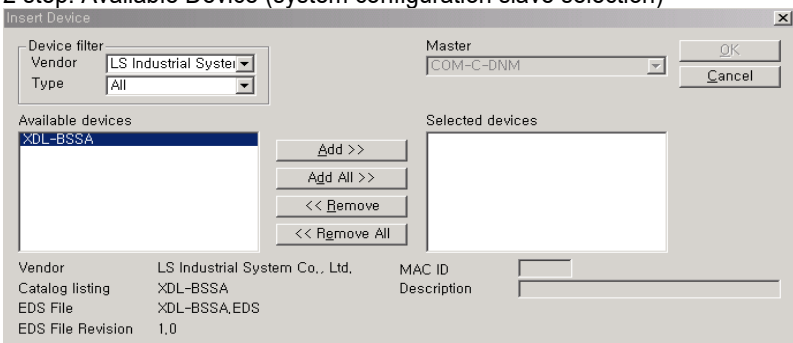
Step	Category	Screen configuration and setting contents
4-1	Slave setting	<p>Recall master setting window</p> <p>Insert → Master or </p>  <p>For Help, press F1 DeviceNet Config Mode</p>
4-2	Slave selection	<p>1 step: Device filter (product classification according to maker)</p>  <p>2 step: Available Device (system configuration slave selection)</p> 

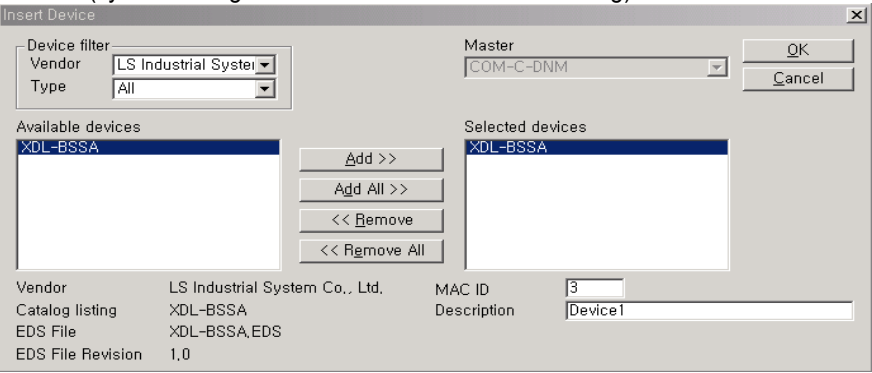
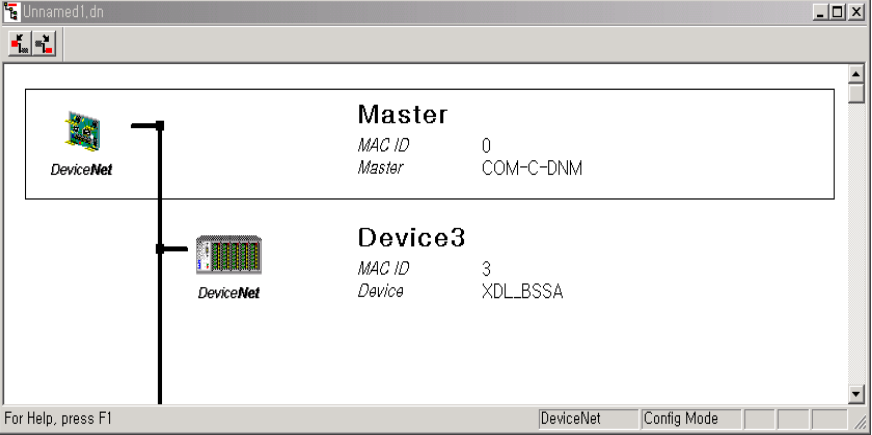
Step	Category	Screen configuration and setting screen
4-3	Station address setting	<p>MAC ID (system configuration slave station address setting)</p>  <p>Adds explanation: Device1(default value)</p>
4-4	Slave Setting completion	

[SyCon 5 step] set the method for slave communication -slave: XPL-BSSA

Menu selection: **Settings** → **Device Configuration**

Step	Category	Screen configuration and setting contents
5-1	Slave communication method setting window	<p>Slave setting</p>
5-2	Slave station address	<p>Station address (MAC ID) setting: 1</p>
5-3	Slave communication method	<p>Communication method selection: Poll</p>
5-4	Slave sending/receiving period setting	<p>Setting the slave module's sending/receiving data period and response status condition - The following figure is default value of each category.</p>
5-5	Slave Data structure (EDS file)	<p>Indicates EDS file's information (data type, IO characteristic, data size)</p> <p>→ If you select BYTE ARRAY through mouse and select Append to configured I/O data, data is indicated as 5-6</p>
5-6	Slave structure data	<p>Set Slave structure(data type, IO characteristic, data size).</p>
5-7	Analog module parameter setting window	<p>Click 'Parameter Data'</p> <p>→ Double-click relevant block of slot 4(AD04A), slot 5(DV04A)</p>

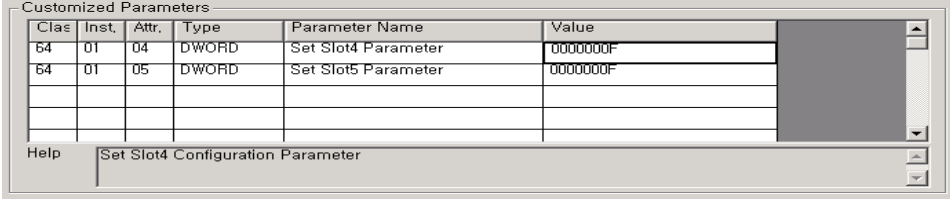
step	Category	Screen configuration screen contents
5-8	Analog module parameter setting	<p>Slot's block which needs parameter setting move to the 'Customized Parameters' window, Set parameter value in the 'Value' block. If setting is completed, press 'OK' and finish parameter setting.</p>  <p>→ each module's parameter setting contents</p> <ul style="list-style-type: none"> - slot4(AD04A):all channels (allowance), input (DC 0~10V), data range(0~4000) - slot5(DV04A):all channels (allowance), output(DC 0~10V), data range(0~4000)

[SyCon 6 step] Serial port selection

: Use RS-232C cable (loader cable) used in CPU module.

So use the cable.

Menu selection: **Settings** → **Device Assignment**

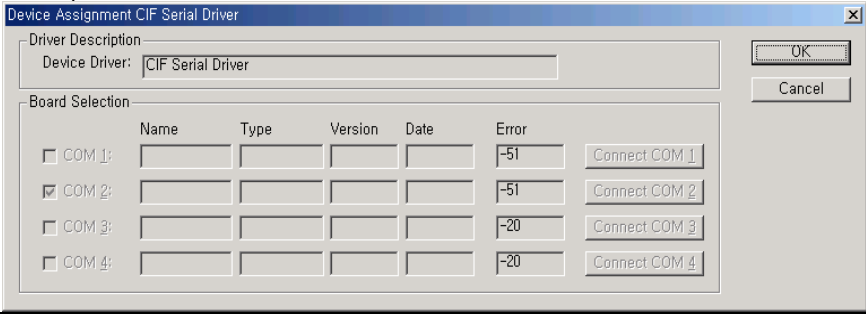
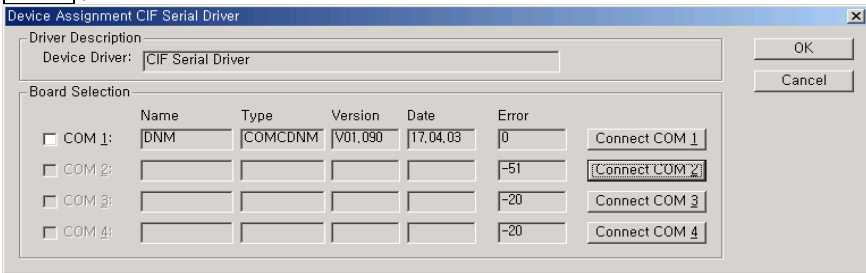
Step	Category	Screen configuration and setting contents
6-1	Setting window for serial port	<p>Serial port</p> 
6-2	Port search	<p>In activated port among Connect COM1 → Connect COM2 → Connect COM3 → Connect COM4, error value is indicated as "0"</p>  <p>Marking COM 1 (<input type="checkbox"/> COM 1: → <input checked="" type="checkbox"/> COM 1:) select OK</p>

[SyCon 7 step] download

Menu selection: **OnLine** → **Download**

[XG5000 1 step] select type of CPU module

Menu selection: **OPTION** → **PLC TYPE setting**

Step	Category	Screen configuration and setting contents
1-1	CPU module selection	 <p>Select CPU module as XGK-CPUS</p>

[XG5000 2 step] Communication method setting

Menu selection: **Online** → **Connection Setting**

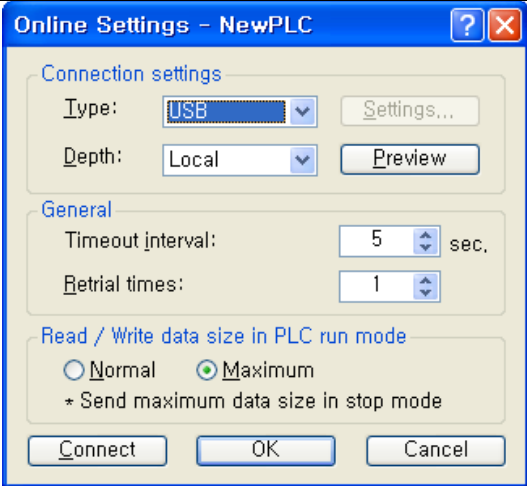
Step	Category	Screen configuration and setting contents
2-1	Communication method setting	 <p>Connecting method: USB Connecting step: local</p>

[XG5000 3 step] connection

Menu selection: **Online** → **Connection**

[XG5000 4 step] I/O information reading

Menu selection: [Online]-[Diagnosis]-[I/O Information]-[I/O Sync]

[XG5000 5 step] High-speed Link setting

Menu selection: parameter → High-speed Link (HS Link) → High-speed Link 1

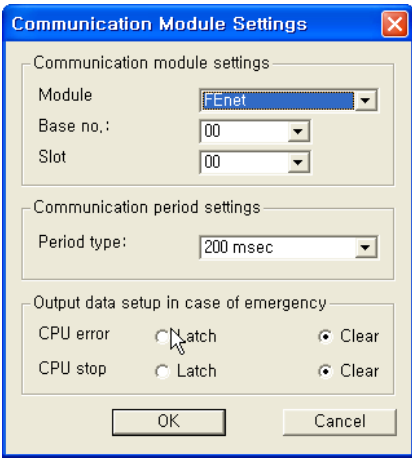
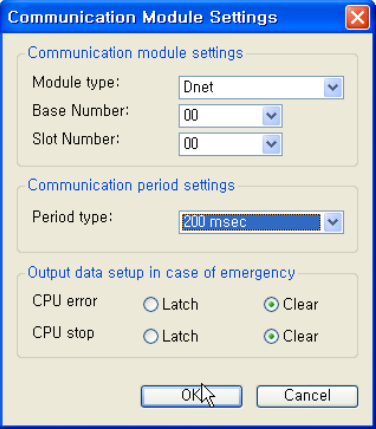
Step	Category	Screen configuration and setting contents
		<p>Initial screen</p> 
5-1	Communication module setting	 <p>set Dnet I/F module in High-speed Link</p> <p>Module type: Dnet Base No.: 00 Slot No.: 00 Communication period setting: 200ms</p>

[XG5000 6-1 Step] SyCon upload

Menu selection: [Online]-[Communication module setting]-[SyCon upload (Dnet)]

Step	Category	Screen configuration and setting contents																																														
6-1	Communication module setting	<p>Initial screen</p>																																														
		<p>Select index in the block window</p>																																														
		<p>SyCon upload</p> <table border="1"> <thead> <tr> <th>Index</th> <th>Mode</th> <th>Station number</th> <th>Communication method</th> <th>Read area</th> <th>Sending data (Byte)</th> <th>Save area</th> <th>Receiving data (Byte)</th> </tr> </thead> <tbody> <tr> <td>0</td> <td>send</td> <td>1</td> <td>Poll</td> <td></td> <td>4</td> <td></td> <td></td> </tr> <tr> <td>1</td> <td>receive</td> <td>2</td> <td>COS</td> <td></td> <td></td> <td></td> <td>4</td> </tr> <tr> <td>2</td> <td>send/receive</td> <td>3</td> <td>COS</td> <td></td> <td>2</td> <td></td> <td>2</td> </tr> <tr> <td>3</td> <td></td> <td></td> <td></td> <td></td> <td></td> <td></td> <td></td> </tr> <tr> <td>4</td> <td></td> <td></td> <td></td> <td></td> <td></td> <td></td> <td></td> </tr> </tbody> </table>	Index	Mode	Station number	Communication method	Read area	Sending data (Byte)	Save area	Receiving data (Byte)	0	send	1	Poll		4			1	receive	2	COS				4	2	send/receive	3	COS		2		2	3								4					
Index	Mode	Station number	Communication method	Read area	Sending data (Byte)	Save area	Receiving data (Byte)																																									
0	send	1	Poll		4																																											
1	receive	2	COS				4																																									
2	send/receive	3	COS		2		2																																									
3																																																
4																																																

[XG5000 6-2 step] Reading area/storage area setting

Menu selection: parameter → High-speed Link (HS Link) → High-speed Link 1 → Block

Step	Category	Screen configuration and setting contents																																												
6-1	Communication module setting	Initial screen <table border="1"> <thead> <tr> <th>Index</th> <th>Master Station No.</th> <th>Station number</th> <th>Mode</th> <th>Read area</th> <th>Sending data (Byte)</th> <th>Save area</th> <th>Receiving data (Byte)</th> </tr> </thead> <tbody> <tr> <td>0</td> <td>0</td> <td>1</td> <td>Send</td> <td></td> <td>4</td> <td></td> <td></td> </tr> <tr> <td>1</td> <td></td> <td></td> <td></td> <td></td> <td></td> <td></td> <td></td> </tr> <tr> <td>2</td> <td></td> <td></td> <td></td> <td></td> <td></td> <td></td> <td></td> </tr> <tr> <td>3</td> <td></td> <td></td> <td></td> <td></td> <td></td> <td></td> <td></td> </tr> </tbody> </table>	Index	Master Station No.	Station number	Mode	Read area	Sending data (Byte)	Save area	Receiving data (Byte)	0	0	1	Send		4			1								2								3											
		Index	Master Station No.	Station number	Mode	Read area	Sending data (Byte)	Save area	Receiving data (Byte)																																					
		0	0	1	Send		4																																							
		1																																												
2																																														
3																																														
Index selection in Block window. <table border="1"> <thead> <tr> <th>Index</th> <th>Index</th> <th>Index</th> </tr> </thead> <tbody> <tr> <td rowspan="5">XDL-BSSA</td> <td rowspan="5">0</td> <td> <table border="1"> <thead> <tr> <th>Index</th> <th>Master Station No.</th> <th>Station number</th> <th>Mode</th> <th>Read area</th> <th>Sending data (Byte)</th> <th>Save area</th> <th>Receiving data (Byte)</th> </tr> </thead> <tbody> <tr> <td>0</td> <td>0</td> <td>1</td> <td>Send</td> <td>p1000</td> <td>4</td> <td></td> <td></td> </tr> <tr> <td>1</td> <td></td> <td></td> <td></td> <td></td> <td></td> <td></td> <td></td> </tr> <tr> <td>2</td> <td></td> <td></td> <td></td> <td></td> <td></td> <td></td> <td></td> </tr> <tr> <td>3</td> <td></td> <td></td> <td></td> <td></td> <td></td> <td></td> <td></td> </tr> </tbody> </table> </td> </tr> </tbody> </table>	Index	Index	Index	XDL-BSSA	0	<table border="1"> <thead> <tr> <th>Index</th> <th>Master Station No.</th> <th>Station number</th> <th>Mode</th> <th>Read area</th> <th>Sending data (Byte)</th> <th>Save area</th> <th>Receiving data (Byte)</th> </tr> </thead> <tbody> <tr> <td>0</td> <td>0</td> <td>1</td> <td>Send</td> <td>p1000</td> <td>4</td> <td></td> <td></td> </tr> <tr> <td>1</td> <td></td> <td></td> <td></td> <td></td> <td></td> <td></td> <td></td> </tr> <tr> <td>2</td> <td></td> <td></td> <td></td> <td></td> <td></td> <td></td> <td></td> </tr> <tr> <td>3</td> <td></td> <td></td> <td></td> <td></td> <td></td> <td></td> <td></td> </tr> </tbody> </table>	Index	Master Station No.	Station number	Mode	Read area	Sending data (Byte)	Save area	Receiving data (Byte)	0	0	1	Send	p1000	4			1								2								3							
Index	Index	Index																																												
XDL-BSSA	0	<table border="1"> <thead> <tr> <th>Index</th> <th>Master Station No.</th> <th>Station number</th> <th>Mode</th> <th>Read area</th> <th>Sending data (Byte)</th> <th>Save area</th> <th>Receiving data (Byte)</th> </tr> </thead> <tbody> <tr> <td>0</td> <td>0</td> <td>1</td> <td>Send</td> <td>p1000</td> <td>4</td> <td></td> <td></td> </tr> <tr> <td>1</td> <td></td> <td></td> <td></td> <td></td> <td></td> <td></td> <td></td> </tr> <tr> <td>2</td> <td></td> <td></td> <td></td> <td></td> <td></td> <td></td> <td></td> </tr> <tr> <td>3</td> <td></td> <td></td> <td></td> <td></td> <td></td> <td></td> <td></td> </tr> </tbody> </table>	Index			Master Station No.	Station number	Mode	Read area	Sending data (Byte)	Save area	Receiving data (Byte)	0	0	1	Send	p1000	4			1								2								3									
		Index	Master Station No.			Station number	Mode	Read area	Sending data (Byte)	Save area	Receiving data (Byte)																																			
		0	0			1	Send	p1000	4																																					
		1																																												
		2																																												
3																																														
High-speed Link block after setting reading area/storage area <table border="1"> <thead> <tr> <th>Index</th> <th>Master Station No.</th> <th>Station number</th> <th>Mode</th> <th>Read area</th> <th>Sending data (Byte)</th> <th>Save area</th> <th>Receiving data (Byte)</th> </tr> </thead> <tbody> <tr> <td>0</td> <td>0</td> <td>1</td> <td>Send</td> <td>p1000</td> <td>4</td> <td></td> <td></td> </tr> <tr> <td>1</td> <td></td> <td></td> <td></td> <td></td> <td></td> <td></td> <td></td> </tr> <tr> <td>2</td> <td></td> <td></td> <td></td> <td></td> <td></td> <td></td> <td></td> </tr> <tr> <td>3</td> <td></td> <td></td> <td></td> <td></td> <td></td> <td></td> <td></td> </tr> </tbody> </table>	Index	Master Station No.	Station number	Mode	Read area	Sending data (Byte)	Save area	Receiving data (Byte)	0	0	1	Send	p1000	4			1								2								3													
Index	Master Station No.	Station number	Mode	Read area	Sending data (Byte)	Save area	Receiving data (Byte)																																							
0	0	1	Send	p1000	4																																									
1																																														
2																																														
3																																														

◆ The structure of reading/storage area of slave module

1. I/O configuration of extension type Pnet module

Communication adapter		Slot 0:	Slot 1:	Slot 2:	Slot 3:	Slot 4:
Reading area		P1000	P1002	M0200	P1003	M0202
Slot0: output 4 byte		TR	Relay	OC	OA	AD
Slot1: relay 2byte		Output	Output	Input	Output	Input
Slot3: DV 8byte		32 point	16 point	32 point	4ch	4ch
Storage area		(XBE-TN32A)	(XBE-RY32A)	(XBE-DC32A)	(XBF-DA04A)	(XBF-AD04A)
Slot2: input 4 byte						
Slot4: AV 8 byte						

2. Reading/storage area of each module

Reading area (master -> slave)				Storage area (slave -> master)					
Device	Transmitting data	Extension output module		Device	Transmitting data	Extension input module			
P1000	14 byte	4 byte	TR output 32 point	M0200	4 byte	DC input 32 point			
P1002		2 byte	Relay 16 point	M0202		2 byte	A/D Conversion 4 channel	Ch.0	
P1003		2 byte	D/A Conversion 4 channel	Ch.0		M0203		2 byte	Ch.1
P1004		2 byte		Ch.1		M0204		2 byte	Ch.2
P1005		2 byte		Ch.2		M0205		2 byte	Ch.3
P1006		2 byte		Ch.3					

[XG5000 7 Step] High-speed Link parameter writing

Menu selection: [Online]-[Write]

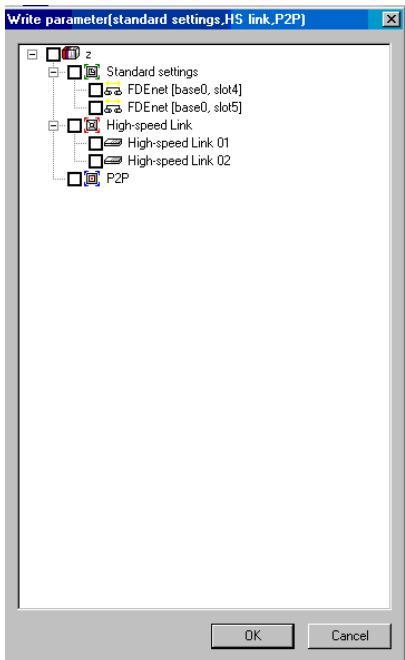
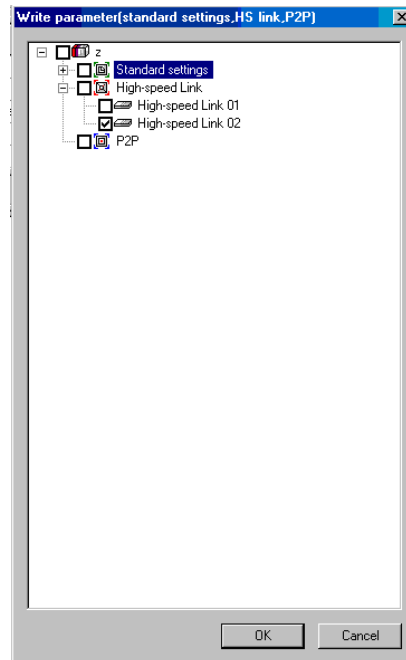
Step	Category	Screen configuration and setting contents	
7-1	Parameter writing	Initial screen	High-speed Link selection
			
Pressing [OK], parameter is downloaded.			

- The data of parameter writing is stored in CPU module.
-So you should back up High-speed Link parameter when changing CPU module.

[XG5000 8 step] High-speed Link enable

Menu selection: [Online]-[Communication module setting]-[Enable link(HS Link, P2P)]

→ Communication between master module and slave module is allowed.

Chapter 7 Rnet Communication

7.1 Overview

The major characteristics of Rnet network are the cost saving of installation/maintenance, diversification of system configuration, easy maintenance, reparation and easy system modification.

This network supports the electrical network (twisted pair cable) that is cost effective and easy to install for the diversification of configuration.

Rnet module can be used in common for GLOFA series and MASTER-K series and applied diversely according to the system application.

In Rnet more than version V1.0, GLOFA Rnet and MASTER-K Rnet module can be in common.

Type	Rnet V1.0	Description
Master (Rnet)	G3L-RUEA	GM3/K1000S Rnet (electric)
	G4L-RUEA	GM4/K300S Rnet (electric)
	G6L-RUEA	GM6/K200S Rnet (electric)
	G7L-RUEA	GM7/K80S Rnet (electric)
	XGL-RMEA	XGT Rnet (electric)

7.2 Communication Specification

Remote I/O module transmission specification (master standard)

Items		Specification
Transmission speed		1Mbps (Rnet module common)
Encoding method		Manchester Biphase-L
Electric	Transmission distance (per segment)	Max. 750m
	Transmission distance (when using the repeater)	Max. 750m * (6 repeaters + 1) = 5.25km
	Transmission wire	Twisted pair shield cable
Max. no of station number		Master + slave = 64 stations (At least one master should be connected.)
Max. protocol size		256 bytes
Access type of communication		Circulated token passing
Communication method		Connection oriented service Connectionless service
Frame error check		$CRC\ 16 = X^{15} + X^{14} + X^{13} + \dots + X^2 + X + 1$

7.3 Communication Parameter Setting

7.3.1 Overview

The method to program in RNET communication module is supposed to enable to communicate with Smart I/O module through *High-speed Link* service as mentioned on 'Chapter 4 Communication Programming'.

High-speed Link

The *High-speed Link* service through Rnet communication module is available to use all the existing function and carry out the communication by simple parameter setting. The parameter shall be set in GMWIN for GLOFA series and in KGLWIN for MASTER-K and in XGT for XG5000 and from RNET version V1.0, min. communication period can be set every scan.

(1) Setting available range of Rnet communication module

Max. High-speed Link point per communication model (Rnet master standard)

Classification		Max. communication point	Max. sending point	Max. block no.	Max. point per block
RNET Communi- cation module	G3L-RUEA	3,780 words	1,920 words	64 (0-63)	60 words
	G4L-RUEA	3,780 words	1,920 words	64 (0-63)	60 words
	G6L-RUEA	3,780 words	1,920 words	64 (0-63)	60 words
	G7L-RUEA	3,780 words	1,920 words	64 (0-63)	60 words
	XGL-RMEA	3,780 words	1,920 words	64 (0-63)	60 words

Communication setting when communicating with Smart I/O module

HS link block setting		Sending/ Receiving period	Address area			HS link information
Sending	Receiving		GLOFA-GM	MASTER-K	XGT	
32	32	20ms ~ 10s	%QW, %IW	P area	Select module	Ref.7.3.2

Remark

- 1) In case of Smart I/O, if 32 points are installed for one module, max. link point is available to use up to 2,016 words for 63 stations.
- 2) For further information, please refer to 'Chapter 4. Communication Programming'.
- 3) XGT's address area is set by Smart I/O

7.3.2 High-speed Link Communication Status Flag

(1) High-speed Link information function

It is available to confirm the reliability of data sent/received to/from other station (remote station) through *High-speed Link* and the user can utilize the above information by combining with *High-speed Link* sending/receiving data as keyword type when writing the program in case of emergency or maintenance.

High-speed Link Information

Classification	Run-link	Link-trouble LINK_ TROUBLE	Sending/ receiving status TRX_MODE	Action mode DEV_MODE	Error DEV_ERROR	High-speed Link status HS_STATE
Information type	Overall information	Overall information	Individual information	Individual information	Individual information	Individual information
Keyword name (□=HS link no. 1,2,3,4)	_HS□RLINK	_HS□LTRBL	_HS□TRX[n] (n=individual parameter no.0~63)	_HS□MOD[n] (n=individual parameter no. 0~63)	_HS□ERR[n] (n=individual parameter no. 0~63)	_HS□STATE[n] (n=individual parameter no. 0~63)
Data type	BIT	BIT	BIT-ARRAY	BIT-ARRAY	BIT-ARRAY	BIT-ARRAY
Monitoring	Available	Available	Available	Available	Available	Available
Program	Available	Available	Available	Available	Available	Available

7.3.3 GMWIN High-speed Link Setting

(1) GMWIN project and Link parameter

If you select the *High-speed Link* parameter from GMWIN project basic screen, the *High-speed Link* parameter basic screen will appear and you can select the corresponding item.

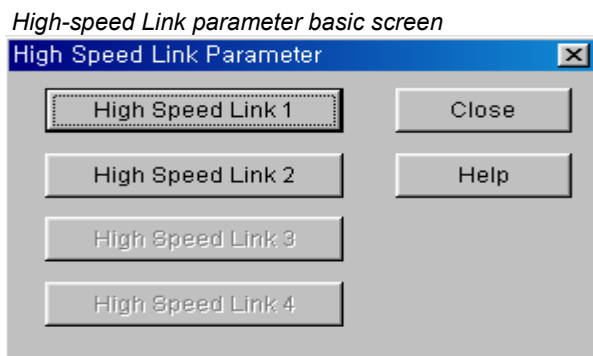

If selecting 'parameter'-'High-speed Link parameter' from project screen, the above menu will appear.

High-speed Link parameter basic screen through GM7 master

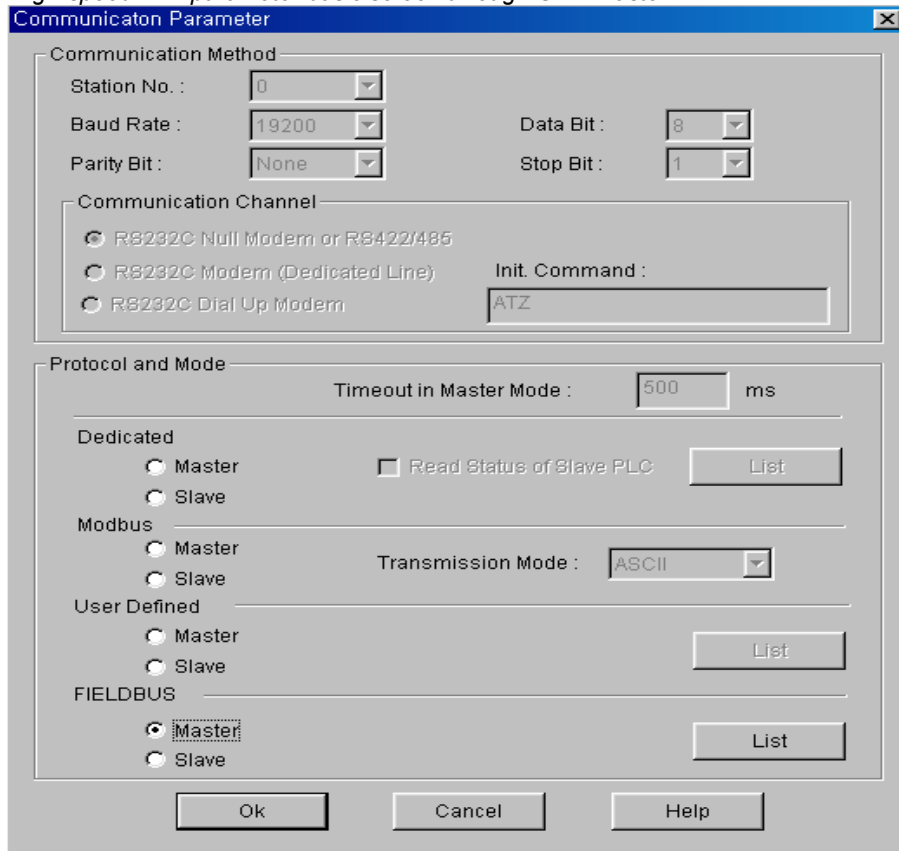

In case of GM7 RNET, select [Link Parameters]-[High Speed Link Parameter] from project screen.

(2) Maximum number to install

The *High-speed Link* items 1~4 means max. installation number of communication module according to PLC CPU type. It is available to install max. 4 communication module for GLOFA GM1/GM2/GM3, CPU/GM4-CPUB, max. 2 for GLOFA GM4-CPUA/GM6, max. 1 for GM7 and max.12 for XGT.

In case of XGT, you can install module as many as max. installation number anywhere, basic base or extension base.

Communication module installation relation per CPU model

Classification	Available communication module	Max. installation number (note 1)
GLOFA-GM3	G3L-RUEA	4 EA
GLOFA-GM4-CPUA	G4L-RUEA	2 EA
GLOFA-GM4-CPUB	G4L-RUEA	4 EA
GLOFA-GM4-CPUC	G4L-RUEA	8 EA
GLOFA-GM6	G6L-RUEA	2 EA
GLOFA-GM7	G7L-RUEA	1 EA
XGT	XGL-RMEA	12 EA

(3) Link parameter setting

If you select the corresponding parameter from parameter setting basic screen, the *High-speed Link* parameter setting first screen will appear as shown in the following figure. When setting the parameter at first, the initial value will be indicated as the below shown figure.

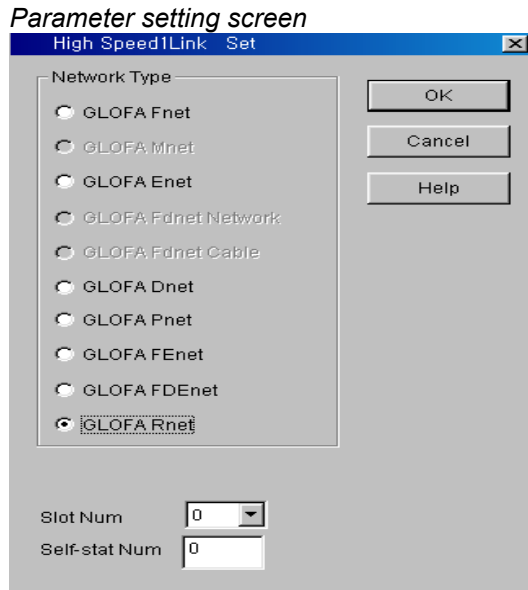

(a) Link setting

Link setting is the item to set the basic items of communication module to perform the *High-speed Link*.

High-speed Link set screen

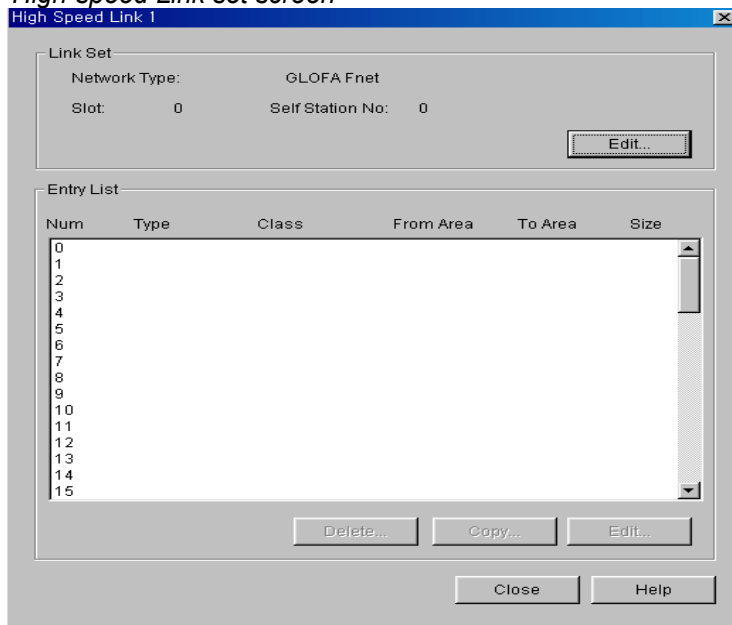

- 1) **Network type:** It sets the installed communication module type and Rnet shall be set.
- 2) **Slot no.:** It sets the position that the communication module to set is installed. (0 ~ 7 slot).
- 3) **Self Station No.:** Enters the setting self station no. into the station address switch of communication module front side. The self station no. of Rnet shall be set as '0' to use.

(b) G7L-RUEA link setting

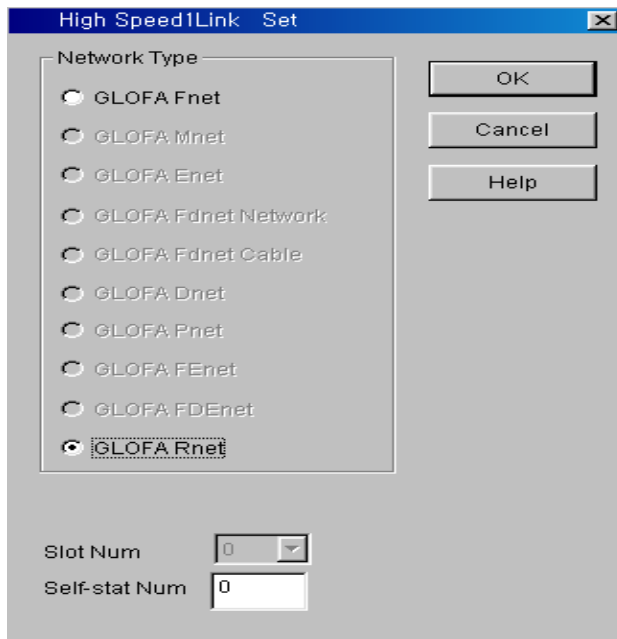

- 1) **Network type:** It sets GLOFA Rnet.
- 2) **Slot no. :** Not-active
- 3) **Self station no. :** The self station no. shall be set as '0' and used.

(3) Entry list setting

Entry list is the area to register the actual data sending/receiving information. For further information, please refer to 'Chapter 4. Communication Programming'.

Remark

GRL-DT4A among Smart I/O modules has 'input' and 'output'. Thus, in case of using the Entry list, please be sure that two lists are required for one module. In this case, when sending/receiving, the station no. shall be set same but the block no. differently.

(4) High-speed Link operation

After setting the *High-speed Link* parameter and executing 'make' from GMWIN compile menu, if you select 'parameter write' and start the *High-speed Link* service, the *High-speed Link* service by the parameter setting begins to run. The *High-speed Link* start order is as follows.

(a) Write Parameter

Parameter download screen

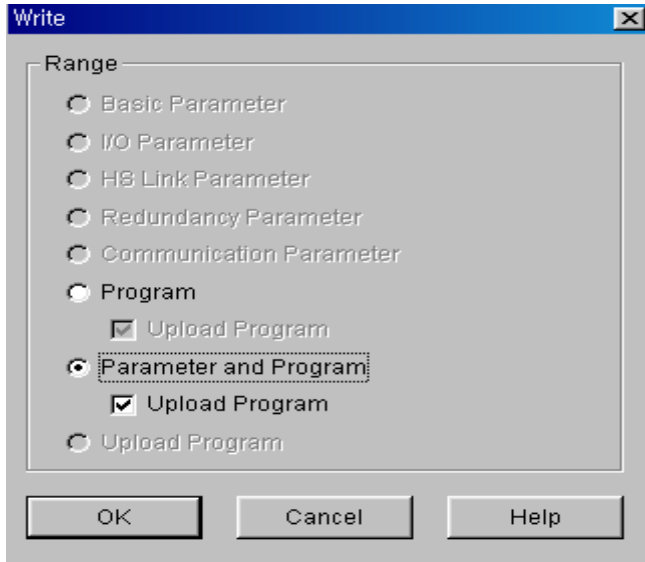

After saving the *High-speed Link* parameter written by the user in the GMWIN project file and connecting with PLC through 'online connect' from GMWIN basic menu, select 'Write' and download the *High-speed Link* parameter or 'parameter and program'.

(b) High-speed Link start

Link Enable setting

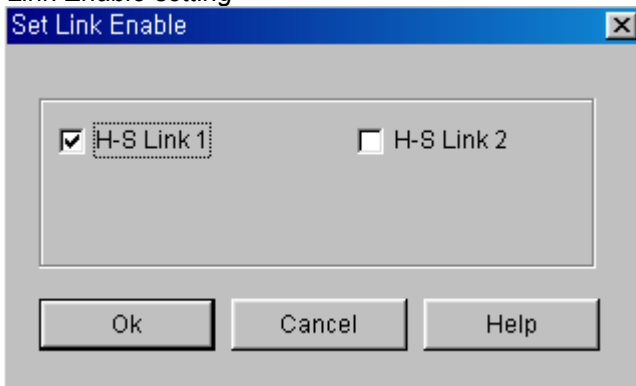

(c) G7L-RUEA *High-speed Link* start



After parameter write, *High-speed Link* is executed after setting the 'Link enable'. Link enable setting is available only in the stop mode of PLC. And if the *High-speed Link* enable setting starts, it carries out the *High-speed Link* regardless of PLC action mode and 'parameter' and 'Link enable information' shall be battery backup in the PLC CPU and preserved if the power is cut off.

(5) *High-speed Link* information monitor

It is available to monitor the current *High-speed Link* status by using 'monitor' function after the GMWIN online connection. There are two kinds of methods to monitor : by selecting 'variable monitor' from monitor menu and by High-speed parameter monitor.

(a) Variable monitor

'Variable monitor' is the function to monitor the necessary items by using the GMWIN flag monitor function and the order to monitor is as follows.

- 1) Select **Variable monitor** from online monitor items.
- 2) Select **flag** from 'register variable ' screen as shown on the figure.
- 3) Select the *High-speed Link* information flag you want to monitor directly one by one from **Variable, Flag list** screen and register. (As `_HSxSTATE[n]`, `_HSxERR[n]`, `_HSxMOD[n]`, `_HSxTRX[n]` is ARRAY flag, the user enters the registration no. of parameter that he wants to monitor directly).

Remark

'X' shows the *High-speed Link* no. and it has the range 1~4 for GM1/GM2/GM3/GM4-CPUB PLC, 1~2 for GM4-CPUA, GM6 PLC and only 1 is effective for GM7. [n] is the individual parameter no. (0~63).

- If you register the variable from the menu and select 'Close', the corresponding monitor screen will appear and the monitoring begins.

High-speed Link information variable register screen

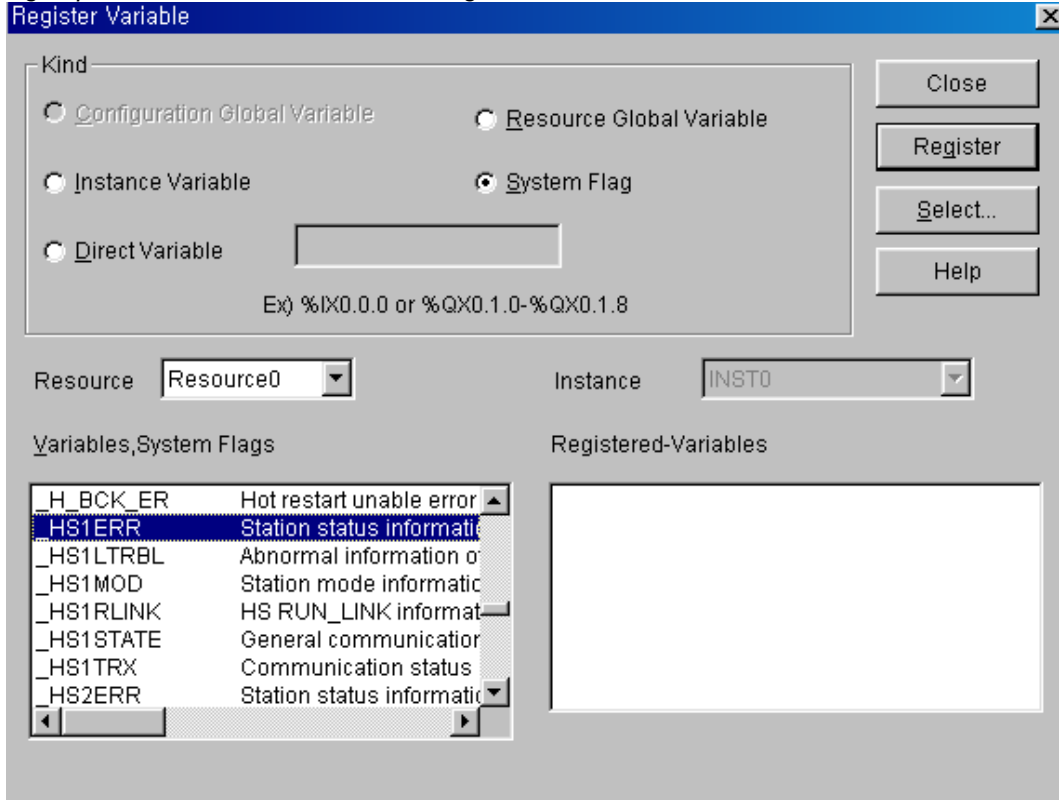

High-speed Link information monitor screen (variable registration)

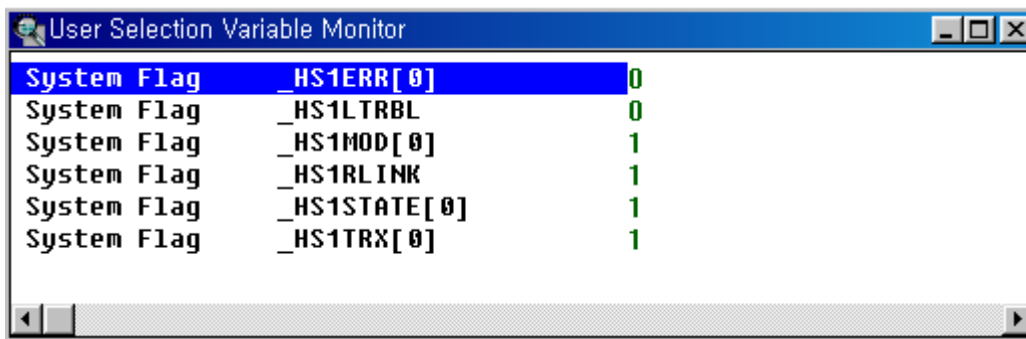

- The detailed contents for the corresponding flag is described in 'Communication module flag application' and it is available to carry out the RNET network status diagnosis by the corresponding flag monitor properly.

(b) High-speed parameter monitor

This is the function to monitor the *High-speed Link* communication status from the menu as below. Select 'LINK Parameters' item from monitor menu of GMWIN online connection.

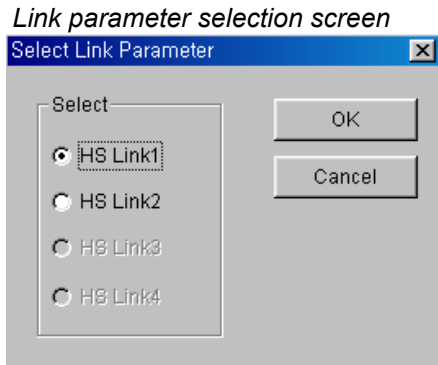

Link parameter monitor shows the general information for RUN-LINK, LINK-TROUBLE on the top screen as below and the individual information such as mode (action mode), communication (sending/receiving status), and an error on the setting parameter items.

High-speed Link parameter monitor screen (Example)

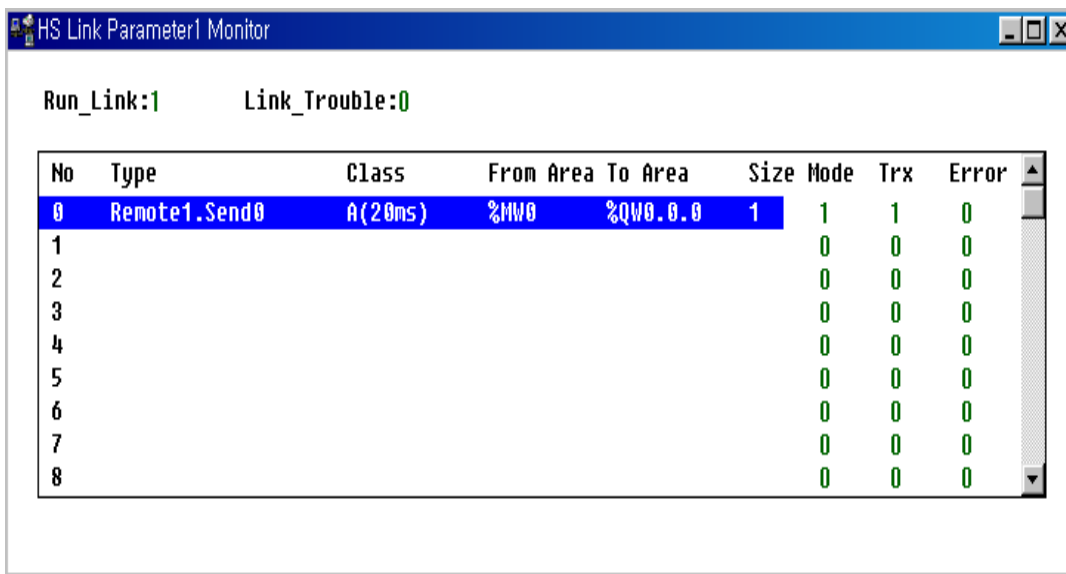

For the meaning of the value monitored on the above figure, please refer to 'Chapter 4. Communication Programming'.

Remark

- RUN-LINK monitoring
In case that GRL-TR4A among Smart I/O is set in the parameter, RUN-LINK shall be indicated as '0'.

7.3.4 KGLWIN Link Setting

(1) KGLWIN project and Link parameter

High-speed Link parameter selects link parameter from KGLWIN project screen and sets the corresponding item. The setting order and the function per item are as follows.

(a) KGLWIN project setting

The following shows parameter basic screen appeared when selecting 'parameter' window.

KGLWIN parameter basic screen (in case of K200S)

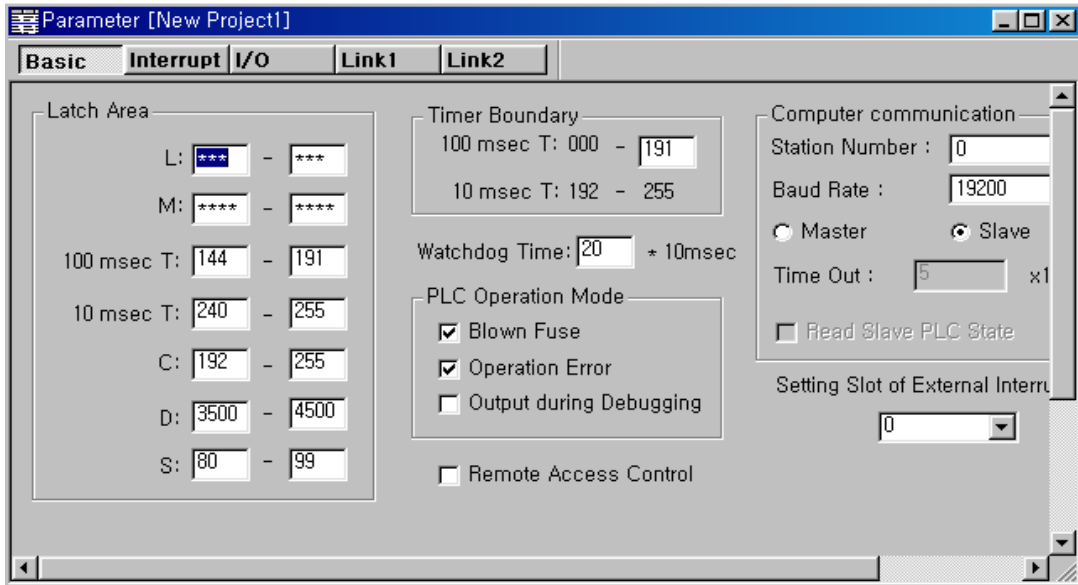

(b) Link parameter basic setting

If you select 'Link 1' from KGLWIN parameter basic screen, the *High-speed Link 1* parameter basic screen as shown below will appear.

Link parameter basic screen

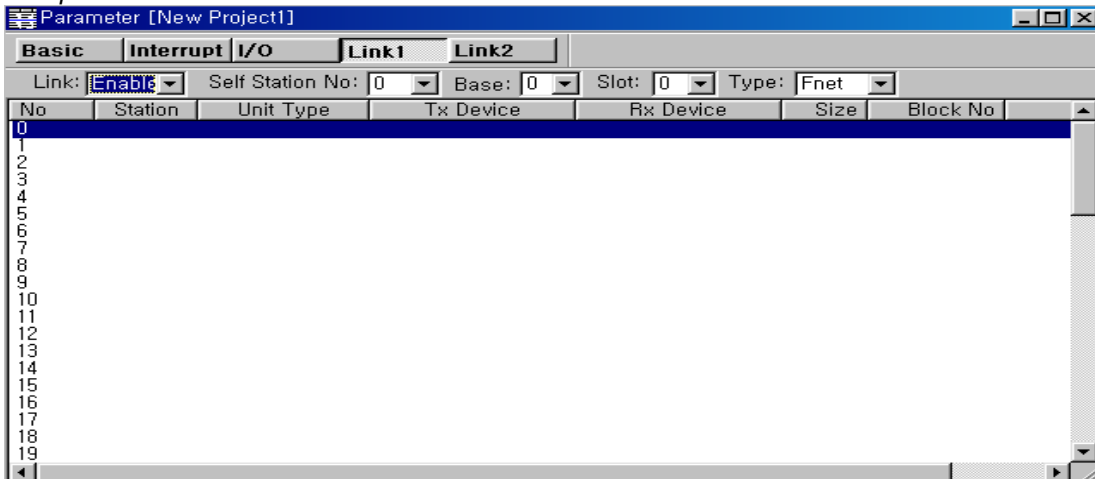

(c) K80S project and Link parameter basic setting

This is parameter basic screen to be appeared when selecting K80S parameter window.

KGLWIN parameter basic screen (in case of K80S)

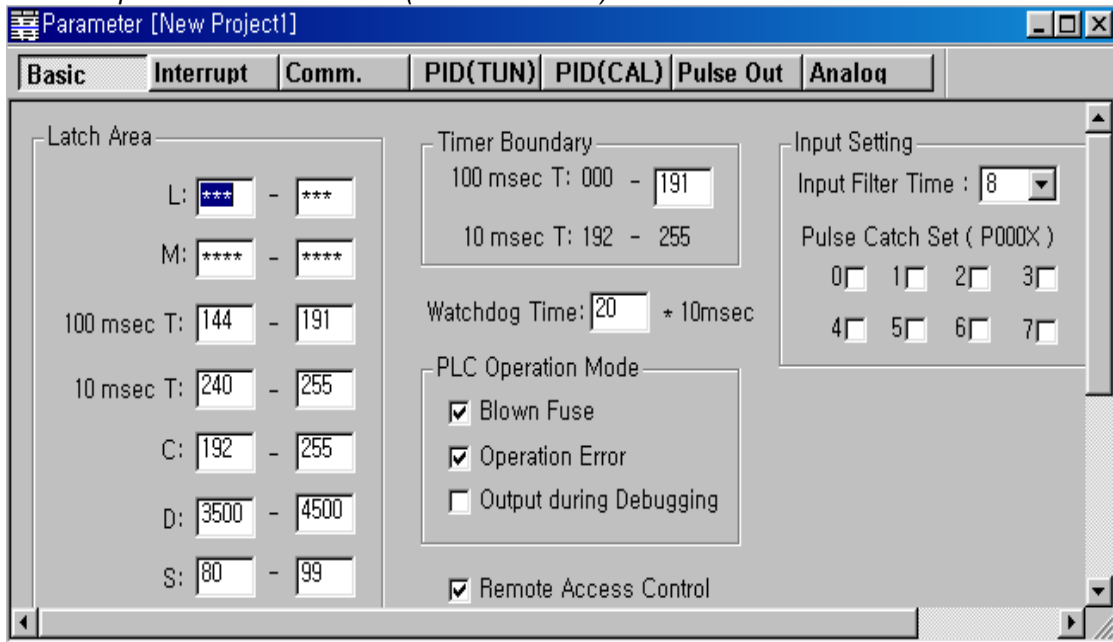

When selecting 'Communication' from KGLWIN parameter basic screen as shown on the above figure, the communication parameter setting screen will appear as below and if you select 'master' from the FIELDBUS menu on the right bottom side and press 'register list', the *High-speed Link* parameter basic screen will appear.

Communication parameter setting screen

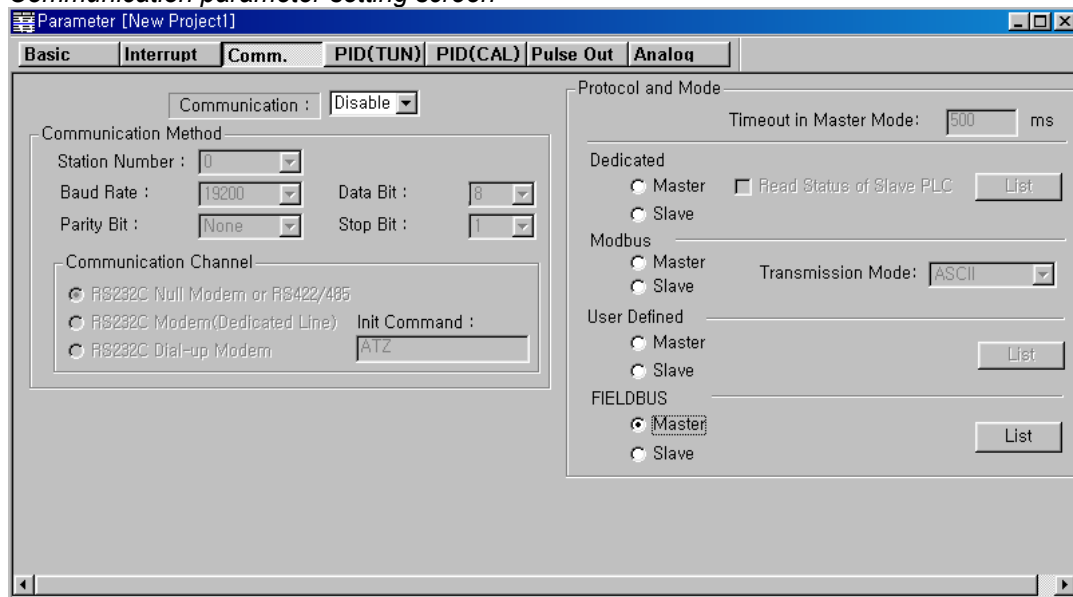

Link parameter basic screen

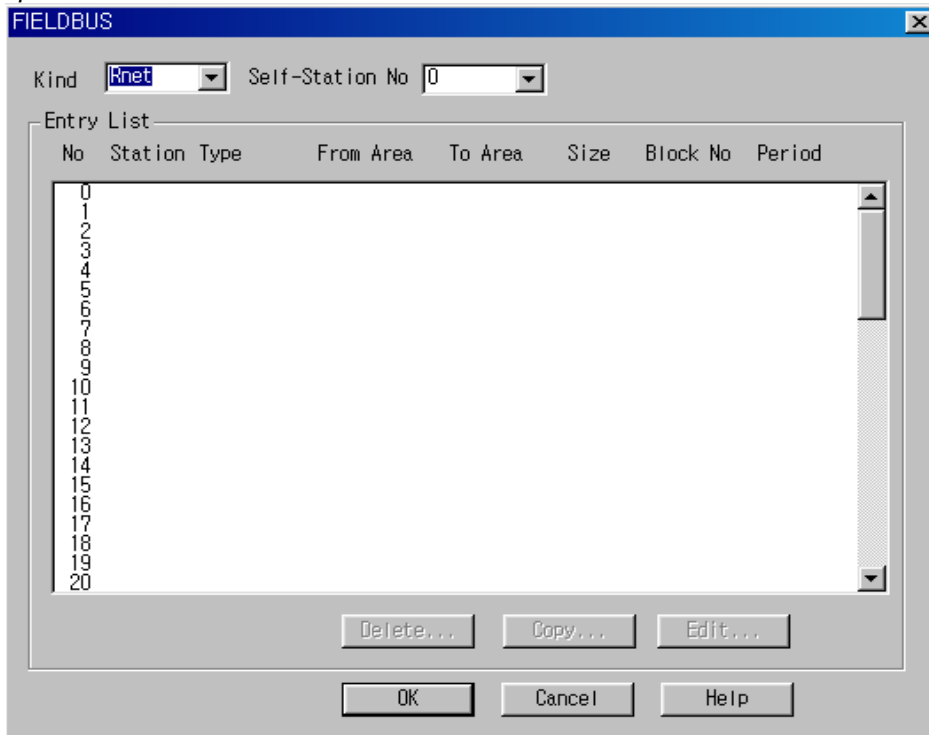

1) **Link1** : This is one of *High-speed Link* type and max.4 communication modules can be installed for K1000S CPU, max. 2 for K300S/K200S and max.1 for K80S. The *High-speed Link* no. is not related to the installed slot no. and only one *High-speed Link* parameter is available to set for one communication module. The table below shows the installation available communication module per CPU model and max. installation amount.

Relation of communication module installation per CPU model

Classification	Communication module	Max. installation amount	Remarks
K1000S	G3L-RUEA	4 EA	Each communication module can be installed by combining each other.
K300S (below v2.2)	G4L-RUEA	2 EA	
K300S (more than v2.2)	G4L-RUEA	4 EA	
K200S	G6L-RUEA	2 EA	
K80S	G7L-RUEA	1 EA	

- 2) **Link**: It sets whether or not to execute the link of communication module. (Enable, Prohibit)
- 3) **Self station no.** : Self station no. should be set as '0' and used.
- 4) **Slot**: This is the communication module installed slot no. and it is set by selecting one from '0'~'7'.

5) **Registration no.** : This is the serial no. to indicate the registered order of the individual parameter and it is set by '0' ~'63'. It is available to register up to a total of 63 and not related to the sending/ receiving order. But it is available to register max. 32 for sending and 32 for receiving respectively.

(d) Link parameter detail setting

If you double-click in the status that the *High-speed Link* registration no.1 is selected, the link parameter setting screen will appear as shown on the figure below.

Link parameter modification screen (in case of the HS link registration no.0)

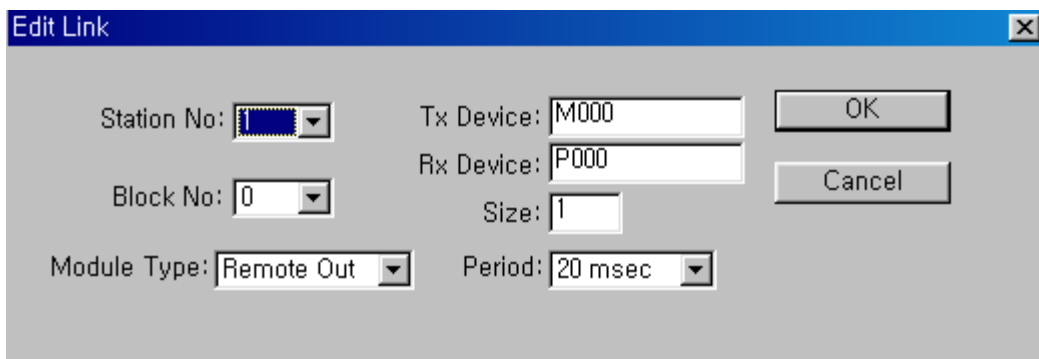

1) **Station no.** : When sending/receiving the data of the setting item, it is required to set other station no. The following table shows the method to set the station no.

Station no. setting method

Communication type	Station no.	Range of station no.
Remote sending	Station no. of other station (remote)	1~63
Remote receiving		

2) **Block No.** : This is the parameter to send/receive lots of data of various areas from one station and distinguish the data of various blocks each other. If setting 32 stations for Smart I/O output module, the input should be set as 31 stations and if setting 32 stations for input. The output should be set as 31 stations because this supports up to 64 stations including master station. In this case, if setting more than 2 same block no. for the same station no., the network will be down. Thus it is not available to set more than 2 blocks for the same station. The max. number of connection station is 64 stations including the master station but if the sending/receiving is set for the one station at the same time, it is not available to set max. station setting.

3) **Module type:** It is set by remote sending and remote receiving.

- a) Remote sending: when sending the data of self station to remote station.
- b) Remote receiving: when receiving the data of remote station to self station.

- 4) **Sending (Tx) / Receiving (Rx) device:** This means the area of sending/receiving. In case of remote sending that means the sending to remote station, set the sending area of self station for the sending device and the receiving area (P area) of remote station for the receiving device. As the remote receiving means the receiving from remote station, set the sending area (P area) of remote station for the sending device and the receiving area of self station for the receiving device.

Sending/Receiving device setting area per communication type

Communication type	Device	Setting available area	Remarks
Remote sending	Sending	P,M,L,K,F,D,T,C all area	Sending area of self station
	Receiving	P area	Receiving area of remote station
Remote receiving	Sending	P area	Sending area of remote station
	Receiving	P,M,L,K,D,T,C area	Receiving area of self station

- 5) **Size:** This means the size of sending/receiving data and the unit is 1 word (16 points). It is available to set max. 60words but for Rnet, it is set as 2 words at the present time because max. points of the current Smart I/O is 2words (32 points).
- 6) **Communication period:** *High-speed Link* is the service to carry out the sending/receiving by the parameter set by the user at the point where the PLC program ends. Thus, when PLC program scan time is short within several ms, communication module begins to transmit the data according to every program scan which results in increasing the communication amount and reducing the effectiveness of overall communication system. Thus, to prevent this, the user can set the sending/receiving period from min.20ms (RNET version V1.0 : from every scan) to max. 10sec. The sending/receiving period means the sending period if the corresponding block is set as 'sending' and the period to check the data receiving of the corresponding block if it is set as 'receiving'.

(e) *High-speed Link* operation

After completing the *High-speed Link* parameter setting, if you click the 'verify' button from download menu and execute the parameter download, the *High-speed Link* service begins. In this case, the corresponding link of the link parameter basic screen should be at Enable status.

Parameter download screen

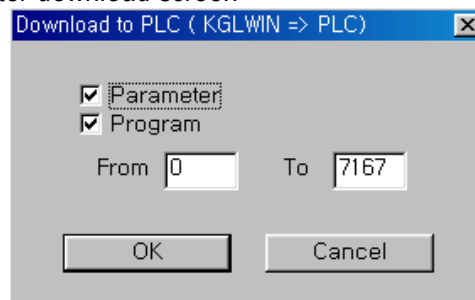

(2) High-speed Link information monitor

After KGLWIN online connection, it is available to monitor *High-speed Link* information by using monitoring window and 'information read' window. There are two kinds of method to monitor : one is by selecting the flag to monitor from flag monitor menu of monitoring window to monitor the individual information and overall information and the other one is by selecting the *High-speed Link* parameter from online-information read menu to monitor overall information.

(a) Flag monitor

Flag monitor is the function to monitor by selecting the necessary flag from KGLWIN [project]→[monitoring] using the flag monitor menu. First, if you select flag monitor button from monitoring window, the flag monitor screen as shown on the figure below will appear and if you press the registration button (▼), the flag registration screen will appear. Select the *High-speed Link* information flag to monitor from the flag registration screen one by one and register it. If flag registration is completed, it begins to monitor in 'monitor' screen. If the monitoring does not work, please check the monitor start mode once again.

Flag monitor screen and Flag registration screen

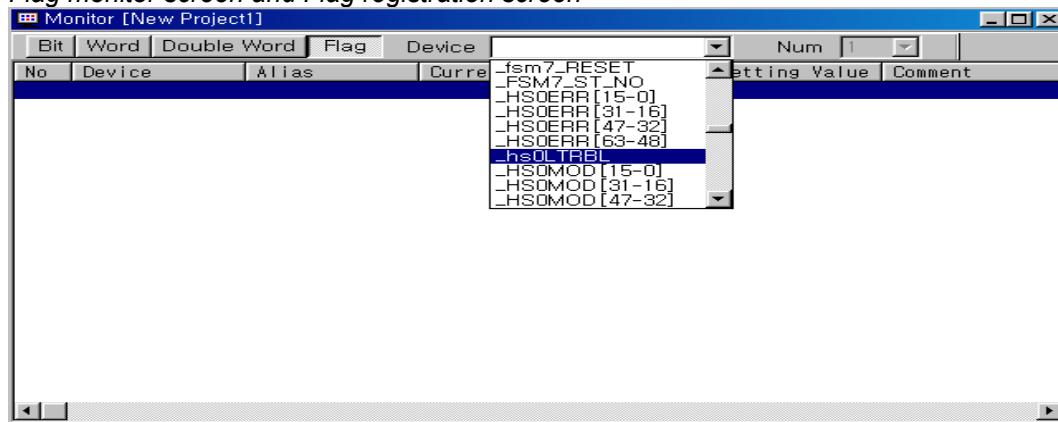

Flag monitor screen (the flag is registered.)

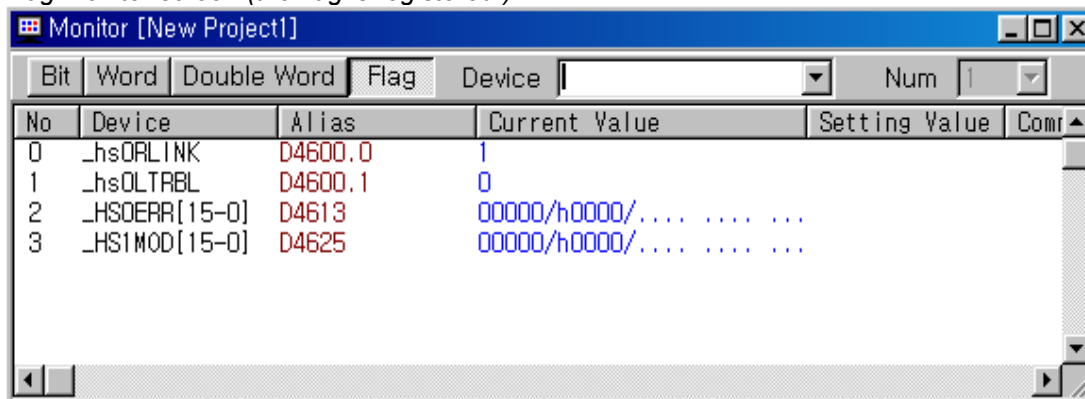

1) Reading information in *High-speed Link* parameter monitor

If you select the *High-speed Link* parameter from the menu 'online-information read', you can see the detailed information for the *High-speed Link* parameter as shown on the above figure.

High-speed Link parameter monitor

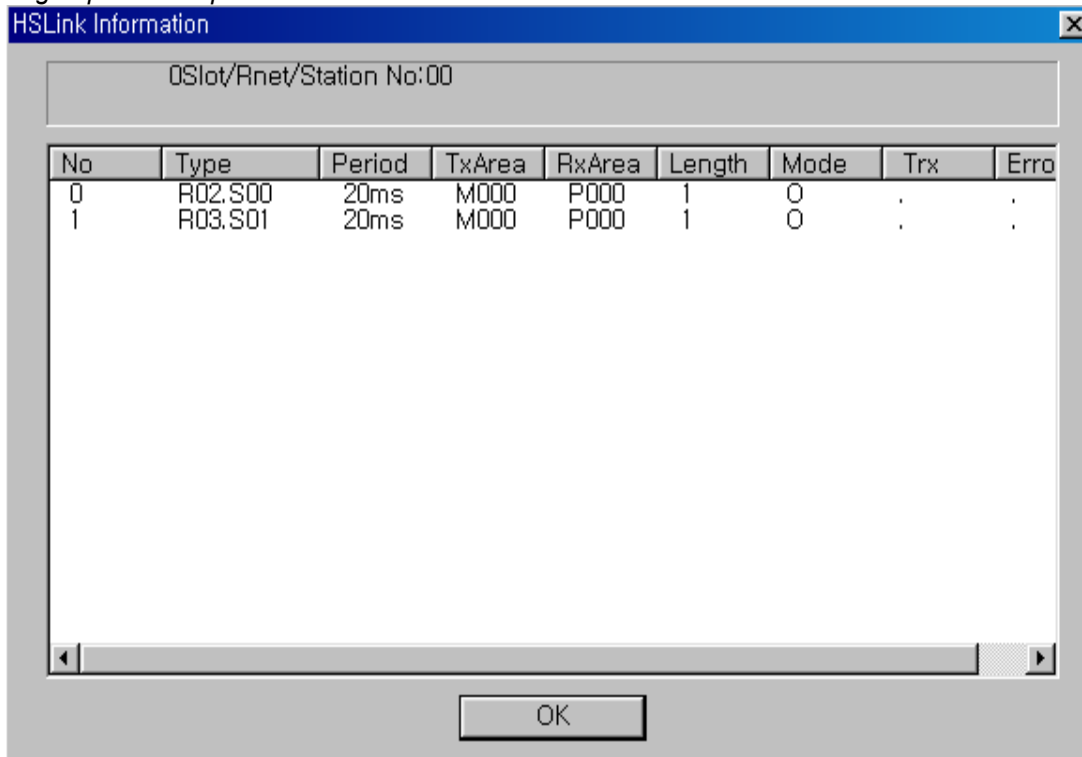

R02.R03 from the type item means Remote station (Smart I/O) 2 and 3 and SO0,S01 means the block no., and this is the parameter to transmit the data of self station (M000) to Remote (Smart I/O) station 2 (P000) through block no.'0'. R03 is also the parameter to transmit the data of self station (M000) to Remote (Smart I/O) station 3 (P000) through block no.1.

2) Link information monitor from information Read

If you select the menu 'Online'-'Information Read'-'Link Information', it is available to easily monitor the link status of the communication module installed per slot.

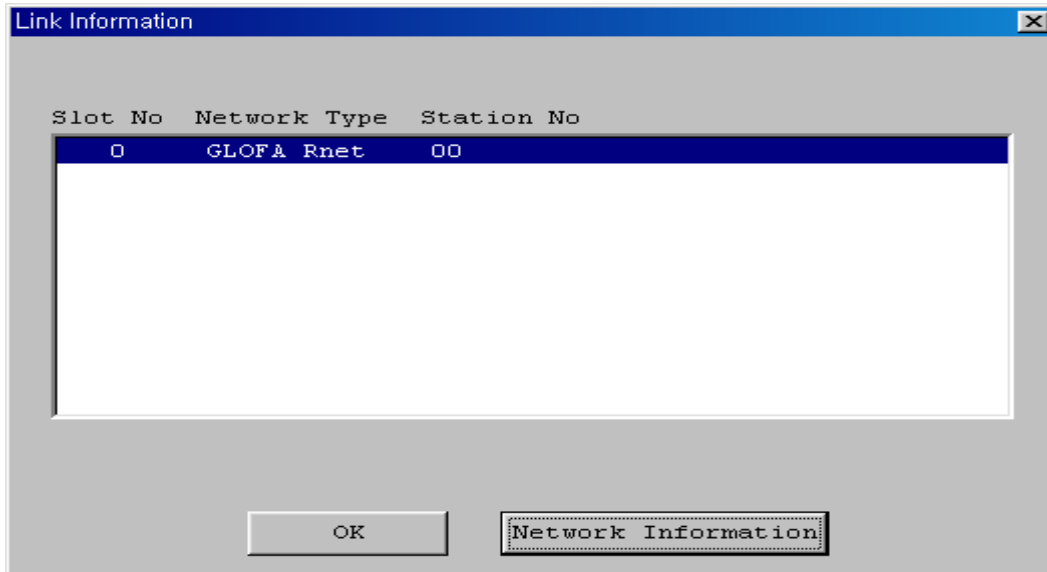

If you select the module to monitor and click the verify button, you can see the connection status of all RNET network connected to the corresponding module. **(except K80S)**

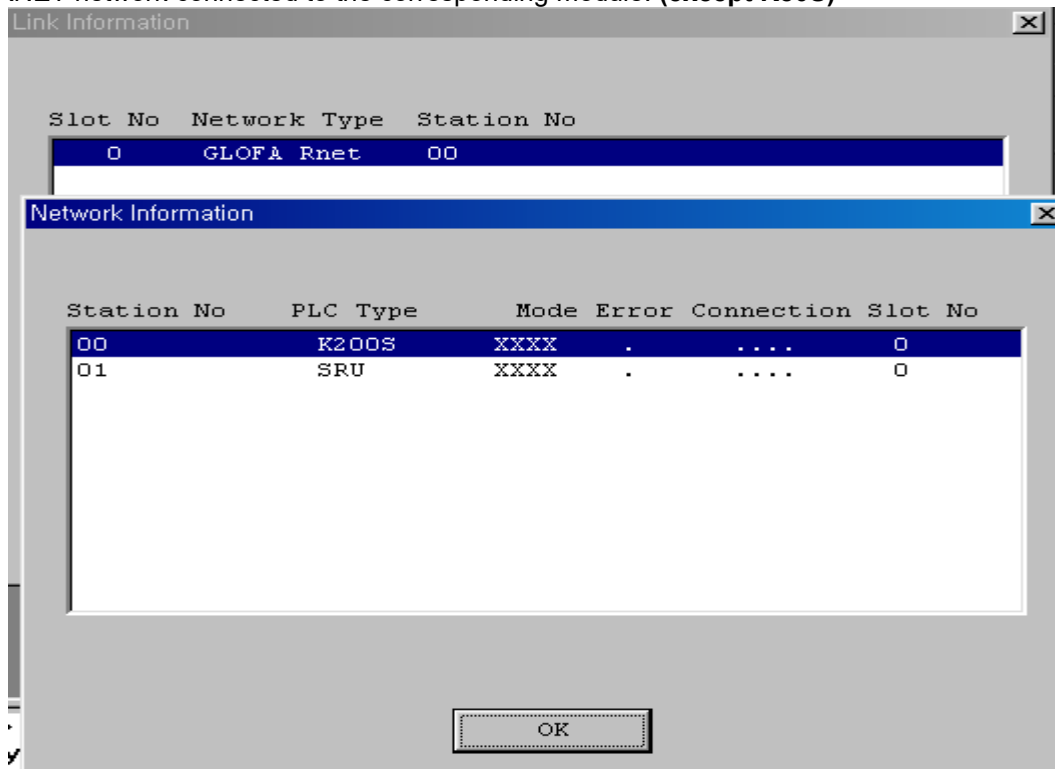

(3) Flag

L area list when using the data link module (in case that installed in Slot no.0)

x : slot no., n : station no. of other station

Keyword	Address no.		Description
_NETx _LIV[n]	L0001~L003F	L0001 ~ L000F (1~15 stations)	This is the flag to inform that the power of other station is normal and the data is sending/receiving normally with other station through communication cable as the Alive information of other station. (Reading only)
		L0010 ~ L001F (16~31 stations)	
		L0020 ~ L002F (32~47 stations)	
		L0030 ~ L003F (48~63 stations)	

High-speed Link detail flag

x : K1000S=9, K300S/K200S=4 m : HS link no.

Keyword	Type	Bit position	Items	Description
_HSmRLINK	Bit	Dx600.0	High-speed Link RUN_LINK information	This indicates that all stations are acting normally according to the parameter set in the High-speed line and will be 'ON' under the following conditions. 1. When all station set in the parameter is RUN mode and there is no an error, 2. When all data block set in the parameter is communicating normally, 3. When the parameter set in the parameter of each station itself is communicating normally, Once 'ON', RUN-LINK maintains the 'ON' unless stopped by Disable.
_HSmLTRBL	Bit	Dx600.1	Abnormal information of High-speed Link (LINK_TROUBLE)	In the status that _HSmRLINK is ON, if the communication status of the station set in the parameter and the data block is as follows, this flag shall be ON. 1. When the station set in the parameter is not RUN mode, 2. When there is an error in the station set in the parameter, 3. When the communication status of data block set in the parameter is not smooth, LINK-TROUBLE shall be ON if the above 1, 2, 3 condition occurs, and if the condition returned to the normal condition, it shall be OFF.

Keyword	Type	Bit position	Items	Description
_HSmSTATE[k] (k=0~63)	Bit Array	Dx601.0 ~ Dx604.15	General communication status information of k data block set in the <i>High-speed Link</i> parameter	This indicates the general status of communication information for each data block of the setting parameter. _HSmSTATE[k] = _HSmMOD[k] & _HSmTRX[k] & _HSmERR[k]
_HSmMOD[k] (k=0~63)	Bit Array	Dx605.0 ~ Dx608.15	Mode information (RUN = 1, others = 0)	Indicates the action mode of the station set in k data block of parameter.
_HSmTRX[k] (k=0~63)	Bit Array	Dx609.0 ~ Dx612.15	Status information (normal=1, abnormal=0)	Indicates whether the communication status of k data block of the parameter is communicating smoothly as set in the parameter.
_HSmERR[k] (k=0~63)	Bit Array	Dx613.0 ~ Dx616.15	The status information of the station set in k data block from the <i>High-speed Link</i> parameter. (normal=1, abnormal=0)	Indicates if an error occurs in the station set in k data block of the parameter.

High-speed Link detail flag when m=1~3

HS link type	D area address no.	Remarks
High-speed Link2 (m=1)	Dx620 ~ Dx633	
High-speed Link3 (m=2)	Dx640 ~ Dx653	
High-speed Link4 (m=3)	Dx660 ~ Dx673	

7.3.5 XGT Rnet's HS Link parameter setting

In order to use XGT Rnet, you should set the High-speed Link parameter through XG5000.

(1) HSL parameter in XG5000

High-speed Link parameter is set through High-speed Link of XG5000 and sequence and category is as follows

(a) Setting sequence of High-speed Link parameter in XG5000

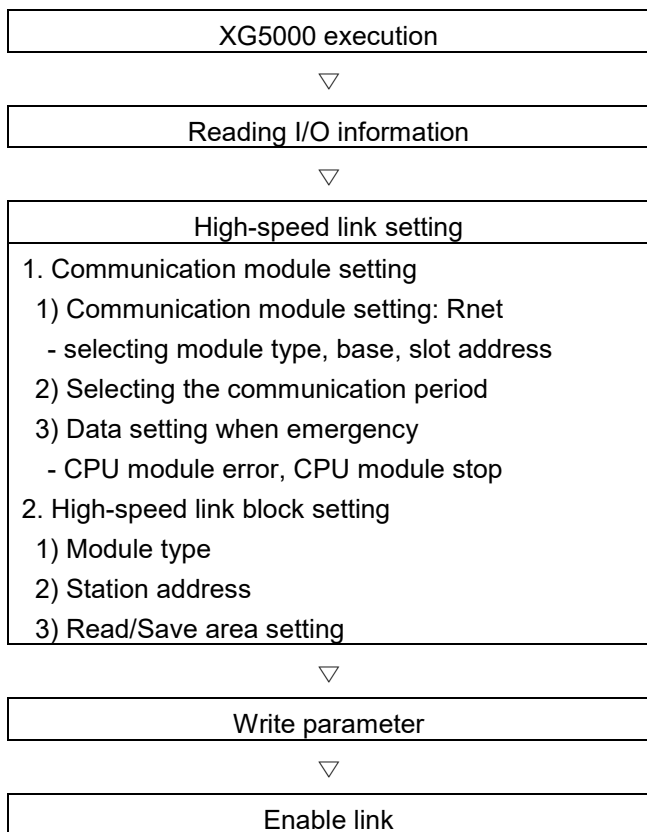

(b) Reading I/O information

- 1) Execute the XG5000 and select new file.
 - a) Press OK after selecting the project name and PLC type.
 - b) When using the parameter saved in PLC, select "Open from PLC".

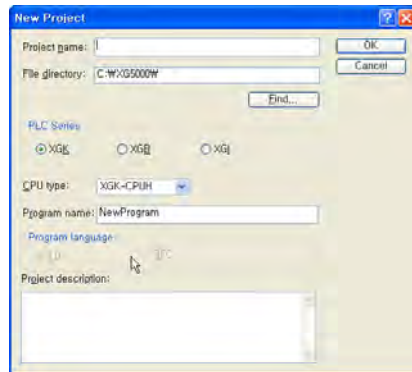

- 2) Click Online Settings and select connection Type and Depth.

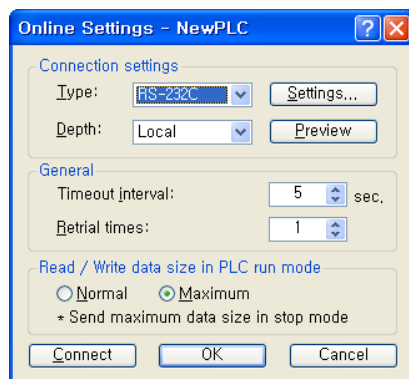

- 3) Click "Read IO Information" and read information about module.

(c) Communication module setting method

The following figure is setting screen of communication module and describes the meaning of the each category.

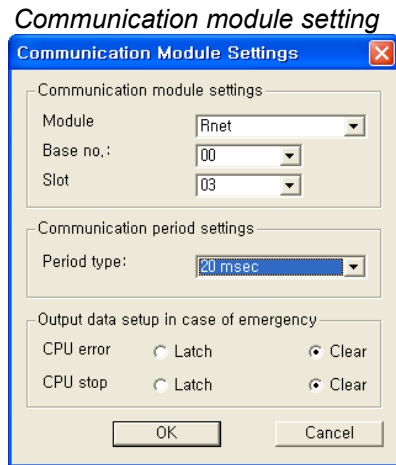

1) Communication Module Settings

- a) It is made when selecting HSL and double-click HSL screen.
- b) Module type: selects module (Rnet) which operates as a master.
- c) Base and slot No.: sets the location where master module is equipped.

2) Communication period setting

- a) Communication period means the period which takes on reading the CPU data from Rnet.
- b) The number of period is 8; Min. 20msec~ Max.10sec

3) Output data setting when emergency

- a) CPU error: It is divided into Latch Clear. Latch holds its data and Clear initialize its data as 0 when an error occurs.
- b) CPU stop: It is divided into Latch Clear. Latch holds its data and Clear initialize its data as 0 when CPU stops.

(d) HSL block setting

HSL block setting is set according to the characteristic of communication module and screen configuration is as follows and refers to the following setting method.

HSL block setting screen

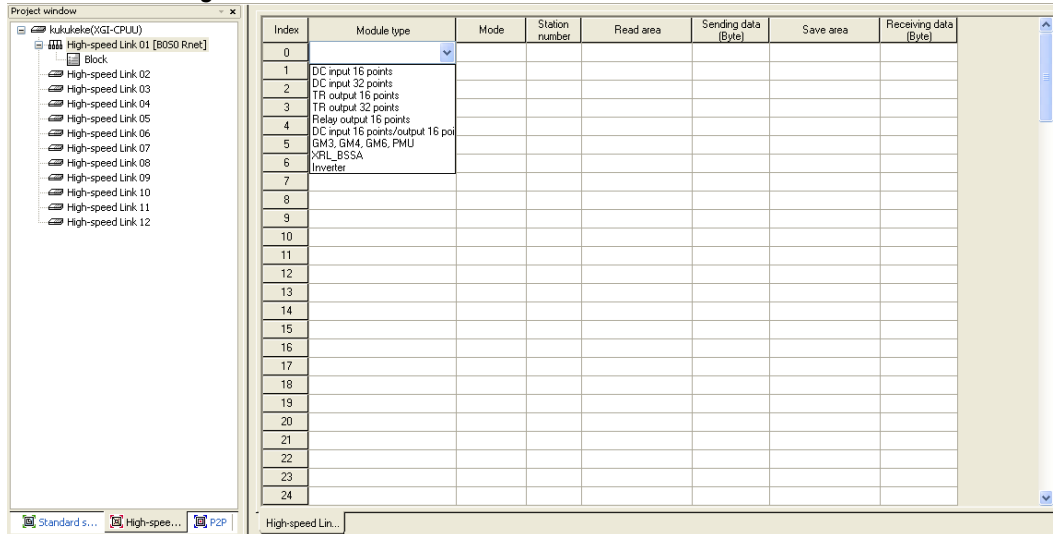

1) Index: It means HSL's block No. and it consists of 0~127(128).

2) Module type: select Smart I/O Rnet's module name.

3) Mode: Mode is set automatically according to the module type except the combined module (DC input 16 point/output 16 point) and Smart I/O Rnet

4) Station No. : It means Smart I/O Rnet's station No.

5) Read area/Save area: When selecting output module, the reading area is activated and outputted. It means PLC's device area which is transmitted into module and when selecting module, Save area is activated and means the PLC Save area where data transmitted from input module is saved. When selecting the combined module, both reading area and Save area is activated

6) Sending/Receiving data: It is set automatically according to the module type.

(e) Parameter writing

Click "parameter writing" in online and select HSL No. and press "OK".

(f) Link enable

Click "link enable" in online and select HSL No. and press "OK".

(2) HSL information monitor

You can check the communication status of Smart I/O which is connected with XGL-RMEA and information about each HSL through the XG5000's system diagnosis menu.

(a) Checking the communication module status

- 1) Click system diagnosis in Online.
- 2) Select XGL-RMEA with right mouse and select Auto scan.
- 3) You can check the Smart I/O connection status through Auto scan.

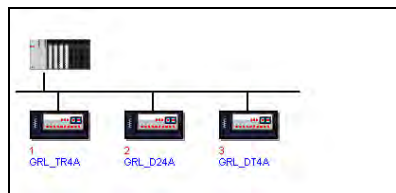

(b) Checking the information about each HSL.

- 1) Click system diagnosis in Online.
- 2) Select XGL-RMEA with right mouse and select HSL.
- 3) You can check communication status about each block through HSL information.
- 4) HSL flag's meaning and device area is as follows.

Name	Indication	unit	Device area	Details
HsState	_HS1_STATE000~127	BIT	L000020~9F	Indicates total status of HSL 1, block 000~127
	_HS2_STATE000~127	BIT	L000520~9F	Indicates total status of HSL 2, block 000~127
	_HS3_STATE000~127	BIT	L001020~9F	Indicates total status of HSL 3, block 000~127
	_HS4_STATE000~127	BIT	L001520~9F	Indicates total status of HSL 4, block 000~127
	_HS5_STATE000~127	BIT	L002020~9F	Indicates total status of HSL 5, block 000~127
	_HS6_STATE000~127	BIT	L002520~9F	Indicates total status of HSL 6, block 000~127
	_HS7_STATE000~127	BIT	L003020~9F	Indicates total status of HSL 7, block 000~127
	_HS8_STATE000~127	BIT	L003520~9F	Indicates total status of HSL 8, block 000~127
	_HS9_STATE000~127	BIT	L004020~9F	Indicates total status of HSL 9, block 000~127
	_HS10_STATE000~127	BIT	L004520~9F	Indicates total status of HSL 10, block 000~127
	_HS11_STATE000~127	BIT	L005020~9F	Indicates total status of HSL 11, block 000~127
	_HS12_STATE000~127	BIT	L005520~9F	Indicates total status of HSL 12, block 000~127
HsMode	_HS1_MOD000~127	BIT	L000100~7F	Indicates run mode of HSL 1, block 000~127
	_HS2_MOD000~127	BIT	L000600~7F	Indicates run mode of HSL 2, block 000~127
	_HS3_MOD000~127	BIT	L001100~7F	Indicates run mode of HSL 3, block 000~127
	_HS4_MOD000~127	BIT	L001600~7F	Indicates run mode of HSL 4, block 000~127
	_HS5_MOD000~127	BIT	L002100~7F	Indicates run mode of HSL 5, block 000~127
	_HS6_MOD000~127	BIT	L002600~7F	Indicates run mode of HSL 6, block 000~127
	_HS7_MOD000~127	BIT	L003100~7F	Indicates run mode of HSL 7, block 000~127
	_HS8_MOD000~127	BIT	L003600~7F	Indicates run mode of HSL 8, block 000~127
	_HS9_MOD000~127	BIT	L004100~7F	Indicates run mode of HSL 9, block 000~127
	_HS10_MOD000~127	BIT	L004600~7F	Indicates run mode of HSL 10, block 000~127
	_HS11_MOD000~127	BIT	L005100~7F	Indicates run mode of HSL 11, block 000~127
	_HS12_MOD000~127	BIT	L005600~7F	Indicates run mode of HSL 12, block 000~127
HsTrx	_HS1_TRX000~127	BIT	L000180~25F	Indicates normal communication between HSL 1 000~127~127 block station
	_HS2_TRX000~127	BIT	L000680~75F	Indicates normal communication between HSL 2 000~127~127 block station

Name	Indication	unit	Device area	Details	
	_HS3_TRX000~127	BIT	L001180~25F	Indicates normal communication between HSL 3 000~127~127 block station	
	_HS4_TRX000~127	BIT	L001680~75F	Indicates normal communication between HSL 4 000~127~127 block station	
	_HS5_TRX000~127	BIT	L002180~25F	Indicates normal communication between HSL 5 000~127~127 block station	
	_HS6_TRX000~127	BIT	L002680~75F	Indicates normal communication between HSL 6 000~127~127 block station	
	_HS7_TRX000~127	BIT	L003180~25F	Indicates normal communication between HSL 7 000~127~127 block station	
	_HS8_TRX000~127	BIT	L003680~75F	Indicates normal communication between HSL 8 000~127~127 block station	
	_HS9_TRX000~127	BIT	L004180~25F	Indicates normal communication between HSL 9 000~127~127 block station	
	_HS10_TRX000~127	BIT	L004680~75F	Indicates normal communication between HSL 10 000~127~127 block station	
	_HS11_TRX000~127	BIT	L005180~25F	Indicates normal communication between HSL 11 000~127~127 block station	
	_HS12_TRX000~127	BIT	L005680~75F	Indicates normal communication between HSL 12 000~127~127 block station	
	HsError	_HS1_ERR000~127	BIT	L000260~33F	Indicates an error mode of HSL 1 000~127
		_HS2_ERR000~127	BIT	L000760~83F	Indicates an error mode of HSL 2 000~127
_HS3_ERR000~127		BIT	L001260~33F	Indicates an error mode of HSL 3 000~127	
_HS4_ERR000~127		BIT	L001760~83F	Indicates an error mode of HSL 4 000~127	
_HS5_ERR000~127		BIT	L002260~33F	Indicates an error mode of HSL 5 000~127	
_HS6_ERR000~127		BIT	L002760~83F	Indicates an error mode of HSL 6 000~127	
_HS7_ERR000~127		BIT	L003260~33F	Indicates an error mode of HSL 7 000~127	
_HS8_ERR000~127		BIT	L003760~83F	Indicates an error mode of HSL 8 000~127	
_HS9_ERR000~127		BIT	L004260~33F	Indicates an error mode of HSL 9 000~127	
_HS10_ERR000~127		BIT	L004760~83F	Indicates an error mode of HSL 10 000~127	
_HS11_ERR000~127		BIT	L005260~33F	Indicates an error mode of HSL 11 000~127	
_HS12_ERR000~127		BIT	L005760~83F	Indicates an error mode of HSL 12 000~127	

7.4 Analog I/O module Parameter Setting

7.4.1 XRL-BSSA analog I/O module Parameter Setting

Type and parameter setting of analog I/O module available to be installed at XRL-BSSA are as follows. * **Parameter setting as below is provided for OS Version 1.3 or higher.**

If you are using V1.2 or less, refer to A.5.2

▶ XBF-AD04A

Memory address	Description	Bit								Configuration
		7	6	5	4	3	2	1	0	
0 : H ¹⁾	Configuration of channels to be used	-	-	-	-	Ch 3	Ch 2	Ch 1	Ch 0	Bit On (1): Operation Bit Off (0): Stop
0 : L ¹⁾	Designation of Input voltage/ current range	Ch3		Ch 2		Ch 1		Ch 0		00: 0 ~ 10V(4 ~ 20mA) 01: 0 ~ 20mA 10: 4 ~ 20mA
1 : H	Designation of output data range	Ch 3		Ch 2		Ch 1		Ch 0		00: 0 ~ 4000 01: -2000 ~ 2000 10: Precise value ²⁾ 11: 0 ~ 1000

▶ XBF-AD08A

Memory address	Description	Bit								Configuration
		7	6	5	4	3	2	1	0	
0 : H	Configuration of channels to be used	Input 7	Input 6	Input 5	Input 4	Input 3	Input 2	Input 1	Input 0	Bit On (1): Operation Bit Off (0): Stop
0 : L	Designation of Input voltage/ current range	Ch 3		Ch 2		Ch 1		Ch 0		00 : 4 ~ 20 mA 01 : 0 ~ 20 mA 10 : 0 ~ 5 V 11 : 0 ~ 10 V
1 : H		Ch 7		Ch 6		Ch 5		Ch 4		
1 : L	Designation of output data range	Ch 6,7		Ch 4,5		Ch 2,3		Ch 0,1		00: 0 ~ 4000 01: -2000 ~ 2000 10: Precise value 11: 0 ~ 1000

► XBF-AD04C

Memory address	Description	Bit								Configuration
		7	6	5	4	3	2	1	0	
0 :H	Configuration of channels to be used	-	-	-	-	Ch 3	Ch 2	Ch 1	Ch 0	Bit On (1): Operation Bit Off (0): Stop
0: L	Designation of Input voltage/ current range	Ch 1				Ch 0				0000: 4 ~ 20mA 0001: 0~20mA 0010: 1~5V 0100: 0~10V 0101: -10V~10V
1: H		Ch 3				Ch 2				
1: L	Designation of output data range	Ch 3	Ch 2	Ch 1	Ch 0	00: 0 ~ 16000 01: -8000 ~ 8000 10: Precise Value 11: 0 ~ 10000				

Note

1) Meaning of memory address

H : High byte (In case that setting area of parameter value of PLC is 0x1234, H byte → 0x12)

► 0:H means that high byte of an word from memory address 0.

L: Low byte (In case that setting area of parameter value of PLC is 0x1234, L byte → 0x34)

► 1:L means that low byte of an word from memory address 1

2) Precise Value

► **Precise Value** = Range of input/output × 100

(Ex: Input range=0~5, Input or Output data range= Precise value

→ Data input range is 0~500)

▶ XBF-DV04A

Memory address	Description	Bit								Configuration
		7	6	5	4	3	2	1	0	
0 : H	Configuration of channels to be used	-	-	-	-	Ch 3	Ch 2	Ch 1	Ch 0	Bit On (1): Operation Bit Off (0): Stop
0 : L	Designation of output range	Ch 3		Ch 2		Ch 1		Ch 0		00: 0 ~ 10V
1 : H	Designation of input data range	Ch 3		Ch 2		Ch 1		Ch 0		00: 0 ~ 4000 01: -2000 ~ 2000 10: Precise value 11: 0 ~ 1000

▶ XBF-DV04C

Memory address	Description	Bit								Configuration
		7	6	5	4	3	2	1	0	
0 : H	Configuration of channels to be used	-	-	-	-	Ch 3	Ch 2	Ch 1	Ch 0	Bit On (1): Operation Bit Off (0): Stop
0 : L	Designation of output range	Ch 3		Ch 2		Ch 1		Ch 0		00: 1~5V 01: 0~5V 10: 0~10V 11: -10~10V
1 : H	Designation of input data range	Ch 3		Ch 2		Ch 1		Ch 0		00: 0 ~ 16000 01: -8000 ~ 8000 10: Precise value 11: 0 ~ 10000

▶ XBF-DC04A

Memory address	Description	Bit								Configuration
		7	6	5	4	3	2	1	0	
0 : H	Configuration of channels to be used	-	-	-	-	Ch 3	Ch 2	Ch 1	Ch 0	Bit On (1): Operation Bit Off (0): Stop
0 : L	Designation of output range	Ch 3		Ch 2		Ch 1		Ch 0		00: 4 ~ 20mA 01: 0 ~ 20mA
1 : H	Designation of input data range	Ch 3		Ch 2		Ch 1		Ch 0		00: 0 ~ 4000 01: -2000 ~ 2000 10: Precise value 11: 0 ~ 1000

▶ XBF-DC04C

Memory address	Description	Bit								Configuration
		7	6	5	4	3	2	1	0	
0 : H	Configuration of channels to be used	-	-	-	-	Ch 3	Ch 2	Ch 1	Ch 0	Bit On (1): Operation Bit Off (0): Stop
0 : L	Designation of output range	Ch 3		Ch 2		Ch 1		Ch 0		00: 4~20mA 01: 0~20mA
1 : H	Designation of input data range	Ch 3		Ch 2		Ch 1		Ch 0		00: 0 ~ 16000 01: -8000 ~ 8000 10: Precise value 11: 0 ~ 10000

► Thermocouple Input Parameter Setting (XBF-TC04S)

Memory address	Description	Bit								Configuration
		7	6	5	4	3	2	1	0	
0 : H	Configuration of channels to be used	-	-	-	-	Ch 3	Ch 2	Ch 1	Ch 0	Bit On (1): Operation Bit Off (0): Stop
0 : L	Configuration of output type	Ch 3		Ch 2		Ch 1		Ch 0		00 : K 01 : J 10 : T 11 : R
1 : H	Designation of input data range	-	-	-	-	Ch 3	Ch 2	Ch 1	Ch 0	0: Centigrade 1: Fahrenheit

► Resistance temperature detector Input Parameter Setting (XBF-RD04A)

Memory address	Description	Bit								Configuration
		7	6	5	4	3	2	1	0	
0 : H	Configuration of channels to be used	-	-	-	-	Ch 3	Ch 2	Ch 1	Ch 0	Bit On (1): Operation Bit Off (0): Stop
0 : L	Configuration of output type	Ch 3		Ch 2		Ch 1		Ch 0		00: PT100 01: JPT100
1 : H	Designation of input data range	-	-	-	-	Ch 3	Ch 2	Ch 1	Ch 0	0: Centigrade 1: Fahrenheit

▶ Analog I/O Combined Module (XBF-AH04A)

Memory address	Description	Bit								Configuration
		7	6	5	4	3	2	1	0	
0 :H	Configuration of channels to be used	-	-	-	-	Output Ch1	Output Ch0	Input Ch1	Input Ch0	Bit On (1): Operation Bit Off (0): Stop
0 : L	Designation of Input/ Output voltage/ current range	Output Ch1		Output Ch0		Input Ch1		Input Ch0		00 : 4 ~ 20 mA 01 : 0 ~ 20 mA 10 : 0 ~ 5 V 11 : 0 ~ 10 V
1 : H	Designation of input/ output data range	Output Ch1		Output Ch0		Input Ch1		Input Ch0		00: 0 ~ 4000 01: -2000 ~ 2000 10: Precise value 11: 0 ~ 1000

7.4.2 How to set XRL-BSSA analog I/O module parameter

In case analog module is installed at XRL-BSSA, 4 byte parameter setting area other than I/O data area should be allocated. You can set analog I/O range by inputting a value at parameter setting area of figure below. At this time, parameter setting area is allocated as Read Area.

*** Parameter setting as below is provided for OS Version 1.3 or higher.
If you are using V1.2 or less, refer to A.5.2**

(1) Device area allocation of analog input/output module

Size	4 byte	2 byte	2 byte	2 byte	2 byte
Area	Parameter setting area	CH 0 data	CH 1 data	...	CH N data

7.4.3 Example of parameter setting

Meaning of each device area according to CPU type is as follows in case system is configured as XRL-BSSA + XBF-DV04C + XBF-AD04C + XBF-AD04A + XBF-DC04C + XBE-DC16A

► In case of XGI series

Index	Module type	Mode	Station number	Read area	Variable name	Variable name comment	Sending data (Byte)	Save area	Variable name	Variable name comment	Receiving data (Byte)
0	XRL_BSSA	Send/Receive	1	%MW0			32	%MW100			18

► In case of XGK series

Index	Module type	Mode	Station number	Read area	Variable name	Variable name comment	Sending data (Byte)	Save area	Variable name	Variable name comment	Receiving data (Byte)
0	XRL_BSSA	Send/Receive	1	M0000			32	M0100			18

► Meaning per each device area

CPU type	Item	Size (byte)	Device area	Contents
XGI	Read area	32byte	MW0 ~ MW1	XBF-DV04C's parameter setting area
			MW2	XBF-DV04C's CH0 output data
			MW3	XBF-DV04C's CH1 output data
			MW4	XBF-DV04C's CH2 output data
			MW5	XBF-DV04C's CH3 output data
			MW6 ~ MW7	XBF-AD04C's parameter setting area
			MW8 ~ MW9	XBF-AD04A's parameter setting area
			MW10 ~ MW11	XBF-DC04C's parameter setting area
			MW12	XBF-DC04C's CH0 output data
			MW13	XBF-DC04C's CH1 output data
			MW14	XBF-DC04C's CH2 output data
	MW15	XBF-DC04C's CH3 output data		
	Save area	18 byte	MW100	XBF-AD04C's CH0 input value save area
			MW101	XBF-AD04C's CH1 input value save area
			MW102	XBF-AD04C's CH2 input value save area
			MW103	XBF-AD04C's CH3 input value save area
			MW104	XBF-AD04A's CH0 input value save area
			MW105	XBF-AD04A's CH1 input value save area
MW106			XBF-AD04A's CH2 input value save area	
MW107			XBF-AD04A's CH3 input value save area	
MW108	XBE-DC16A's input value save area			
XGK	Read area	32 byte	M0 ~ M1	XBF-DV04C's parameter setting area
			M2	XBF-DV04C's CH0 output data
			M3	XBF-DV04C's CH1 output data
			M4	XBF-DV04C's CH2 output data
			M5	XBF-DV04C's CH3 output data
			M6 ~ M7	XBF-AD04C's parameter setting area
			M8 ~ M9	XBF-AD04A's parameter setting area
			M10 ~ M11	XBF-DC04C's parameter setting area
			M12	XBF-DC04C's CH0 output data
			M13	XBF-DC04C's CH1 output data
			M14	XBF-DC04C's CH2 output data
	M15	XBF-DC04C's CH3 output data		
	Save area	18 byte	M100	XBF-AD04C's CH0 input value save area
			M101	XBF-AD04C's CH1 input value save area
			M102	XBF-AD04C's CH2 input value save area
			M103	XBF-AD04C's CH3 input value save area
			M104	XBF-AD04A's CH0 input value save area
			M105	XBF-AD04A's CH1 input value save area
M106			XBF-AD04A's CH2 input value save area	
M107	XBF-AD04A's CH3 input value save area			
M108	XBE-DC16A's input value save area			

Note

Cautions in setting an analog parameter

1. After setting a parameter, make sure you restart a power of XRL-BSSA module.

7.5 Program Example

7.5.1 GLOFA-GM Series

Program Example 1:

In GM3 base, the communication module (G3L-RUEA) is installed for slot 0, output 32 points for slot 1, and input 32 points for slot 2, respectively. This is the example to send GM3 %IW0.2.0 data to station 1 and output the data of station 2 to GM3 %QW0.1.0.

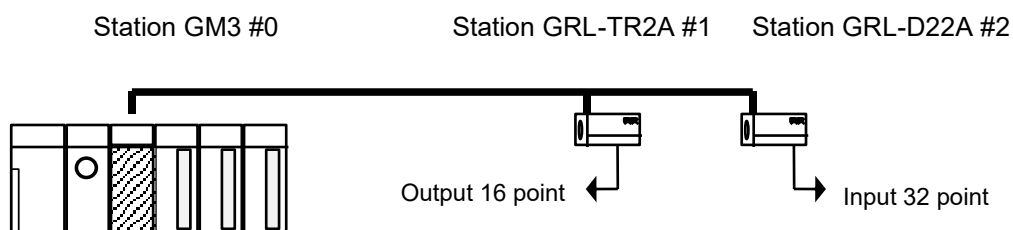

To perform the program example, first make the I/O configuration table as shown on the table below and write the *High-speed Link* parameter in the corresponding CPU module, respectively.

I/O configuration and Sending/receiving flow

Sending/Receiving structure	Read area	Save area	Block no.	Size
Sending from GM3→station 1	%IW0.2.0	%QW0.0.0	0	1
Receiving from GM3←station 2	%IW0.0.0	%QW0.1.0	1	1

(a) Working order

- 1) Station number allocation and communication cable connection
- 2) The user program writing (per each station)
- 3) Make the data sending/receiving map same type of the above table
- 4) Parameter setting in GMWIN *High-speed Link* parameter setting item
- 5) Execute 'compile' and 'make' from compile menu
- 6) Execute program and parameter write from online menu.
- 7) Select 'Link Enable set' from online menu and set the *High-speed Link* Enable that corresponds to the setting no.
- 8) Change the mode to RUN from online menu.
- 9) Start 'monitor' from online menu and check if RUN-LINK is ON without an error in the *High-speed Link* monitor.
- 10) If an error occurs, repeat the above from '1'.

Sending parameter setting from GM3 station 0 to station 1

High Speed1Link Item Edit

Station Type: Local, Remote

Station No: 1

Mode: Send, Receive

Block No: 0

Area:

From: %MW, %IW, %QW, 0.2.0

To: %MW, %IW, %QW, 0.0.0

Send Period: A(20ms)

Size: 1

OK Cancel Help

Receiving parameter setting by GM3 station 0 from station 2

High Speed1Link Item Edit

Station Type: Local, Remote

Station No: 2

Mode: Send, Receive

Block No: 2

Area:

From: %MW, %IW, %QW, 0.0.0

To: %MW, %IW, %QW, 0.1.0

Send Period: A(20ms)

Size: 1

OK Cancel Help

Remark

1) Do not register the same station no. more than 2 or the same block no. more than 2.

7.5.2 MASTER-K Series

Program Example 1

Here it describes the *High-speed Link* parameter setting method to perform the data communication in RNET master system below with the I/O structure same as shown on the table below.

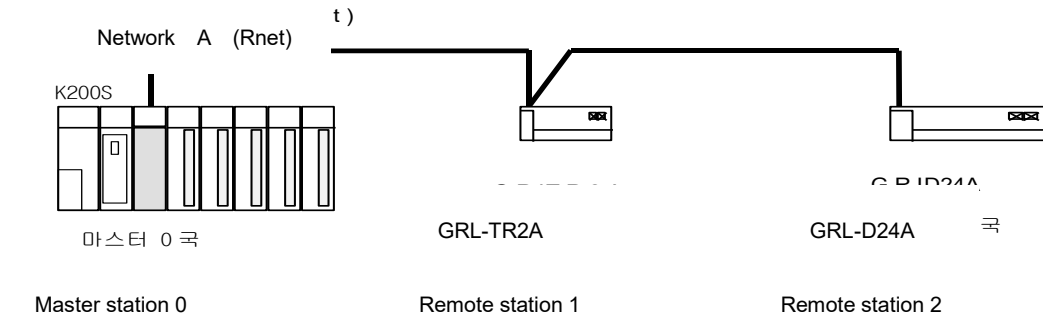

I/O configuration and Sending/Receiving flow

Sending/Receiving structure		Sending area	Receiving area
K200S (station 0)	Sending :--> GRL-TR2A (station 1)	P0003	-
		-	P000
	Receiving :<-- GRL-D24A (station 2)	P0000	-
		-	P0004

From the example, K200S CPU sends the input value of input module (P3) installed in self station slot 2 by 1 word and outputs the data received from other station to P4 output module. The *High-speed Link* parameter configuration and program for data exchange on the above are described in the figure below. The program can be used in common and sets only link parameter respectively. (it is available to use the same program and parameter in the K1000S/K300S RNET communication.)

(a) The user program writing

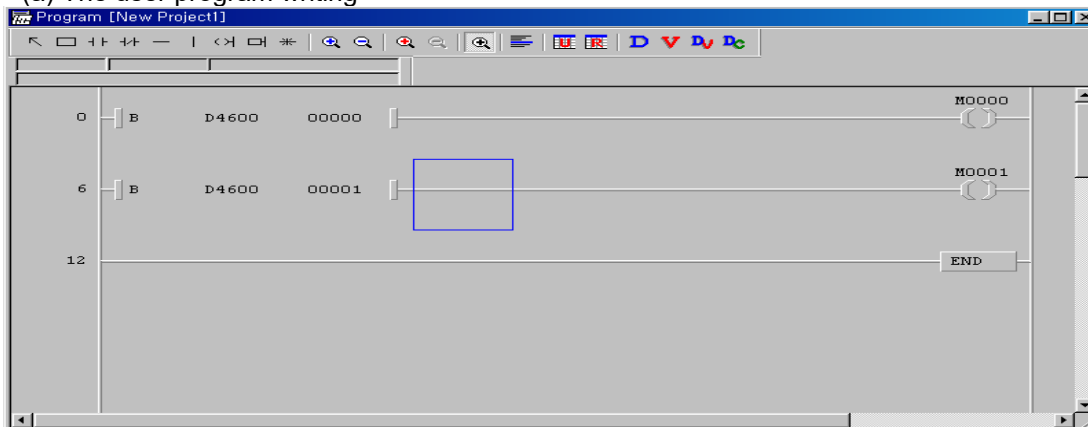

The above figure is the program to set M0000 area when RUN-LINK is ON and M0001 area when LINK-TROUBLE flag is ON.

(b) *High-speed Link* parameter setting

To make Station 0, 1, 2 to change the data as specified on the table in the master configuration system, the user should write the user program first and then prepare the data sending/receiving map as shown on the table. And to send/receive the data as shown on the table, it is required to write the *High-speed Link* parameter and download it in PLC and the *High-speed Link* start shall be carried out according to the following order.

- 1) Station number allocation and communication cable connection
- 2) The user program writing (per each station)
- 3) Make the data Sending/Receiving map
- 4) Parameter setting in KGLWIN *High-speed Link* parameter setting item
- 5) Execute program and parameter download from the online menu
- 6) Change the mode to RUN from the online menu.
- 7) Check the *High-speed Link* status through flag monitor
- 8) If an error occurs, repeat the above from '1)'.

(c) The *High-speed Link* parameter for the system of program example is set as follows.

K200S (station 0) High-speed Link parameter

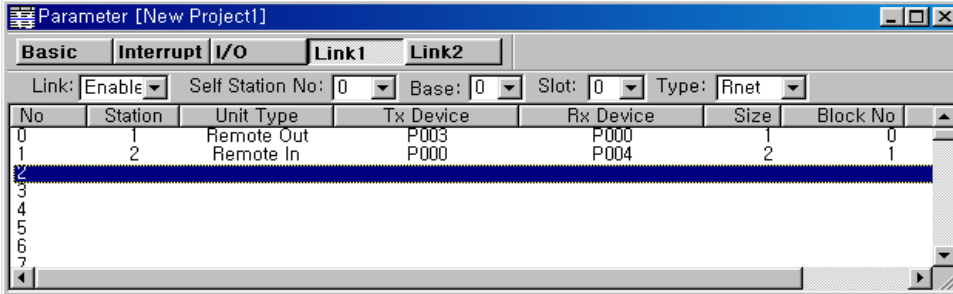

(d) *High-speed Link* speed fixing method.

The system of Example 1) is a simple system that the communication module of station 3 sends/receives the data of 1word per each station. And the calculation method for communication speed is as follows.

- Formula $St = P_scanA + C_scan$
 $St = \text{High-speed Link max. transmission time}$
 $P_scanA = \text{PLC A max. program scan time}$
 $C_scan = \text{max. communication scan time}$

As P_scanA is PLC scan time on the above, if assuming that it is 3ms each for the above program, (available to verify through online-information read-PLC information)

$$C_scan = n1 \times 180us + n2 \times 828us + 1,000us \text{ ----- [formula 7-1]}$$

n1 : output station number
n2 : input station number

$$C_scan = 1 \times 180 + 1 \times 828 + 1,000 = 2,008us$$

$$St = P_scanA(=3ms) + Cscan(2ms) = 5ms$$

Therefore, the sending/receiving period should be set as min. more than 5ms.

7.5.3 XGT series

(1) Program Example 1

Here it describes the *High-speed Link* parameter setting method to perform the data communication in RNET master system below with the I/O structure same as shown on the table below.

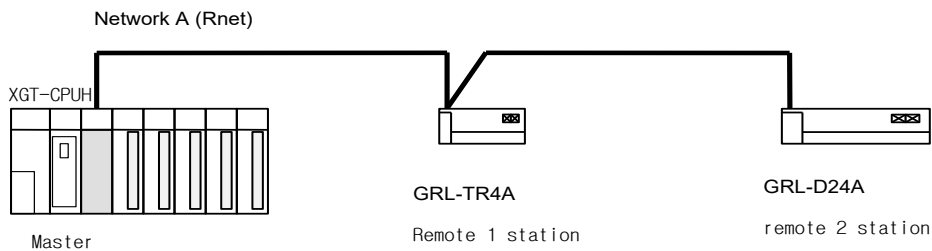

I/O configuration and Sending/Receiving flow

Sending/Receiving structure		Sending area	Receiving area
XGK (station 0)	Sending (1station)	M200	-
		-	GRL-TR4A
	Receiving (2 station)	GRL-D24A	-
		-	M300

As the above figure, Rnet master module (XGL-RMEA) in the PLC (XGT) is connected with 32 point output module (GRL-TR4A) and 32 input module (GRL-D24A).

(a) GRL-TR4A's operation

It receives M200 and M201's data of PLC from Rnet master module and output.

(b) GRL-D24A's operation

PLC receives the GRL-D24A's input value through Rnet master module and save it in M300 and M301 of PLC

(c) Setting in the XG5000

1) Setting the HSL

As described in 7.3.5, connect Rnet master module with Smart I/O and configure the system and set the parameter through the HSL and the sequence is as follows.

- a) Select new file in file menu and set suitable CPU
- b) After setting the connection in Online, connect PC
- c) Click the HSL of project window
- d) By double-clicking, the HSL 01, set module and module equipment location
- e) Double-click the block and set the detail parameter.
- f) Click “parameter writing” in Online and select each HSL No. and write
- g) Click link enable in online menu and select each HSL No. and write

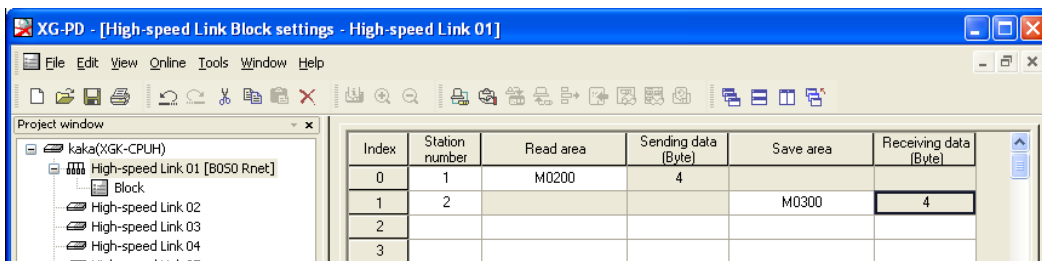

(d) Program

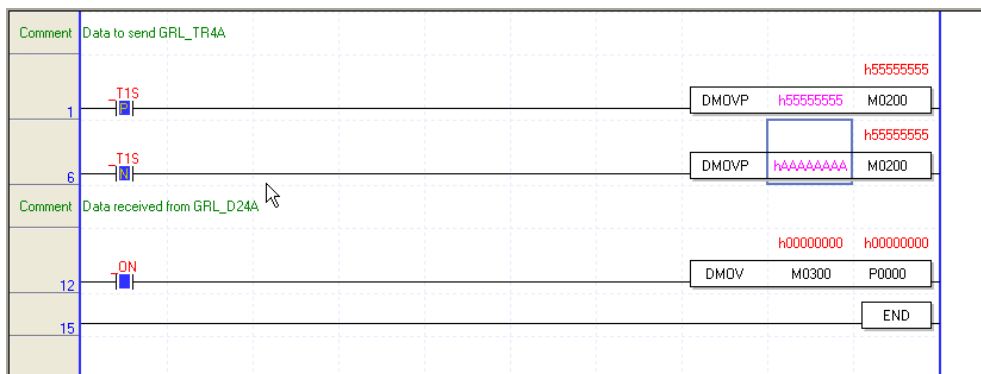

Chapter 8 Modbus Communication

8.1 Overview

Smart I/O module communication supports modbus through GM3/4/6/7 master module.

(G3L-CUEA/G4L-CUEA/G6L-CUEC/G7L-CUEC)

This supports ASCII mode that communicates using ASCII (American Standard Code for Information Interchange) data and RTU (Remote Terminal Unit) mode that uses HEX data and the function code used in the modbus is supported by the *Function Block* and only function code 01, 02, 03, 04, 05, 06, 15, 16 are supported.

8.2 Communication Specification

8.2.1 ASCII Mode

- (1) This communicates using ASCII data.
- (2) Each frame uses ':(Colon) : H3A)' for the header, CRLF (Carriage Return-Line Feed) : HOD HOA) for the tale.
- (3) Max. 1second interval between Characters is allowed.
- (4) It uses LRC to check the error.
- (5) Frame structure (ASCII data)

Classification	Header	Station no.	Function code	Data	LRC	Tale (CR LF)
Size	1 byte	2 byte	2 byte	n byte	2 byte	2 byte

8.2.2 RTU Mode

- (1) It uses HEX data to communicate.
- (2) There is no header and tale, and it starts from station no. (Address) and ends the frame with CRC.
- (3) It has min. 3.5 Character Time Interval between frames.
- (4) When exceeding more than 1.5 Character Time between Characters, please disregard the corresponding frame.
- (5) It uses 16 bit CRC to check the error.
- (6) Frame structure (HEX data)

Classification	Station no.	Function code	Data	CRC
Size	1 byte	1 byte	n byte	2 byte

Remark
<p>1) The size to compose one letter (character) is called '1 character', that is, 1 character is 8 bits = 1byte.</p> <p>2) 1 character time means the time to take when sending 1 character.</p> <p>Ex.1) 1 character time calculation in communication speed 2,400 bps</p> <p style="padding-left: 40px;">2,400 bps is the speed that takes 1 second to send 2,400 bits. When sending 1 bit,</p> <p style="padding-left: 80px;">$1 \text{ (sec)} \div 2,400 \text{ (bit)} = 0.41 \text{ (ms)}$.</p> <p>Thus, 1 character time is $0.41 \text{ (ms)} \times 8 \text{ (bit)} = 3.28 \text{ (ms)}$.</p>

8.2.3 Station no. (Address) Area

- (1) Smart I/O series supports 0 ~ 31.
- (2) Station 0 uses Broadcast address. Broadcast address is the station no. the slave device except self station no. recognizes and responds, and it does not support in Smart I/O series.

8.2.4 Function Code Area

- (1) In Smart I/O series, it supports Modicon function code 01, 02, 03, 04, 05, 06, 15, 16 only.
- (2) When the response format is Confirm+ (ACK response), the same function code is used.
- (3) When the response format is Confirm- (NCK response), set the 8th bit of function code as '1' and return.

Ex) when function code is 03,
 - specify only the function code part as there is a difference in the function code only.

[Request]	0000 0011 (H03)
[ACK response]	0000 0011 (H03)
[NAK response]	1 000 0011 (H83)

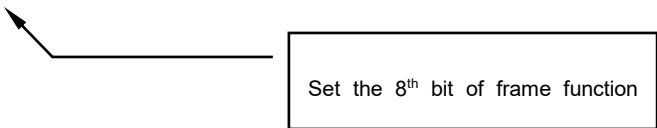

8.2.5 Data Area

- (1) It transmits the data using ASCII (ASCII mode) data or HEX (RTU mode).
- (2) The data structure is changed according to each function code.
- (3) Response frame uses the data area as response data or error code.

8.2.6 Error Check (LRC Check/CRC Check) Area

- (1) LRC (Longitudinal Redundancy Check): this is used in ASCII mode and takes the 2's complement from the sum of frame except the header/the tale and carries out the ASCII conversion.
- (2) CRC (Cyclical Redundancy Check): this is used in RTU mode and uses 2 bytes of CRC check regulation s.

Remark

All numeric data uses by mixing the hexadecimal, decimal, binary number. Each number is specified as following example.

The example that decimal number 7, 10 is marked as each number.

- Hexadecimal : H07, H0A or 16#07, 16#0A
- Decimal : 7, 10
- Binary : 2#0111, 2#1010

8.2.7 Function Code Type and Memory Mapping

Code	Function code name	Modicon PLC Data address	Smart I/O Mapping	Remarks
01	Read output contact status (Read Coil Status)	0XXXX (bit-output)	%QX0~%QX31	Bit read
02	Read input contact status (Read Input Status)	1XXXX (bit-input)	%IX0~%IX31	Bit read
03	Read output registers (Read Holding Registers)	4XXXX (word-output)	%QW0~%QW3	Bit read
04	Read input register (Read Input Registers)	3XXXX (word-input)	%IW0~%IW3	Word read
05	Write output contact 1 bit (Force Single Coil)	0XXXX (bit-output)	%QX0~%QX31	Bit write
06	Write output register 1 word (Preset Single Register)	4XXXX (word-output)	%QW0~%QW3	Word write
15	Write output contact continuously (Force Multiple Coils)	0XXXX (bit-output)	%QX0~%QX31	Bit write
16	Write output register continuously (Preset Multiple Register)	4XXXX (word-output)	%QW0~%QW3	Word write

MASTER-K mapping

Bit area		Word area	
Address	Data area	Address	Data area
H0000	P area	h0000	P area
H1000	M area	H1000	M area
H2000	L area	H2000	L area
H3000	K area	H3000	K area
H4000	F area	H4000	F area
H5000	T area (contact)	H5000	T area (current value)
H6000	C area (contact)	H6000	C area (current value)
H8000, H9000	D area	H7000	S area

8.2.8 Modbus Addressing Regulation

(1) GLOFA-GM series

In Smart I/O series, the address in the frame begins from '0' and maps with Modicon data address 1, and 'n'th address of Smart I/O series becomes Modicon address n+1. And in Smart I/O series, it uses only the continuous M area without being distinguished by output contact (0XXXX), input contact (1XXXX), output register (4XXXX), input register (3XXXX). That is, the output contact 1(00001) of Modicon product is indicated as the address '0' of communication frame and the input contact 1(10001) of Modicon product is indicated as the address '0' of communication frame.

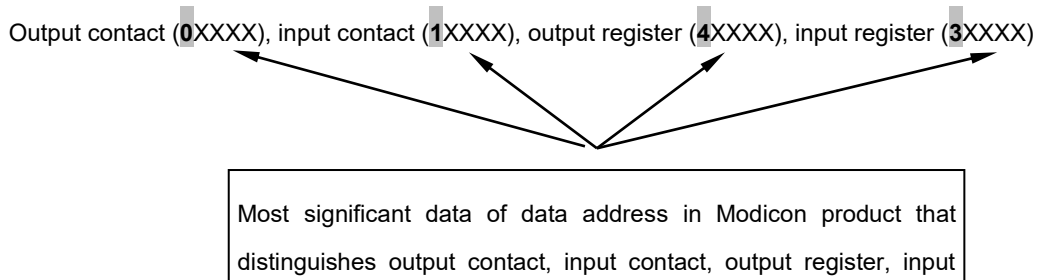

(2) MASTER-K series

XXXX area of Modicon PLC data address is allocated by the mapping of MASTER-K series. For example, when you try to read M0002 bit of MASTER-K in Modicon PLC, use the function code 01 or 02 and set the data address as H1002. When you try to read D0010 word area, use the function code 03 or 04 and set the address as H800A.

(3) XGT series

XXXX area of data address of Modbus is mapped with that of XGT as 1:1. Write frame at P2P block by using Modbus RTU/ASCII client of XG5000.

For more detail, refer to CH 8.3 Communication parameter setting.

8.2.9 Data Size

Smart I/O series supports the data size of 128bytes for ASCII mode and 256bytes for RTU mode.

8.2.10 Wiring diagram

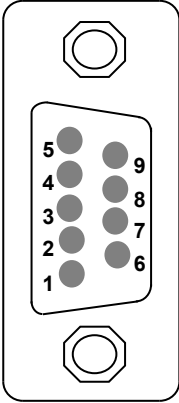
 <p>Male Type</p>	PIN spec.	Smart I/O (9-PIN)
	1	(1) No.1 : reserved (OS Upgrade)
2	(2) No.2 : reserved (OS Upgrade)	
3	(3) No.3 : RX-	
4	(4) No.4 : RX+	
5	(5) No.5 : GND	
6	(6) No.6/7: reserved	
7	(7) No.8 : TX-	
8	(8) No.9 : TX+	
9		

8.3 Communication Parameter Setting

8.3.1 GLOFA-GM Series

(1) In case of GM3/4/6 is the master,

(a) Insert communication *Function Block*

When communicating modbus communication with Smart I/O using GM3/4/6 as the master, it is required to insert the following *Function Block* library into GMWIN Lib folder.

Classification		Corresponding <i>Function Block</i> library	Remarks
GM3	G3L-CUEA	Modbus.3FB	GMWIN Library adding
GM4	G4L-CUEA	Modbus.4FB	
GM6	G6L-CUEA	Modbus.6FB	

1) Select GMWIN menu [Project] → [Add Item] → [Library] and insert the corresponding library per model.

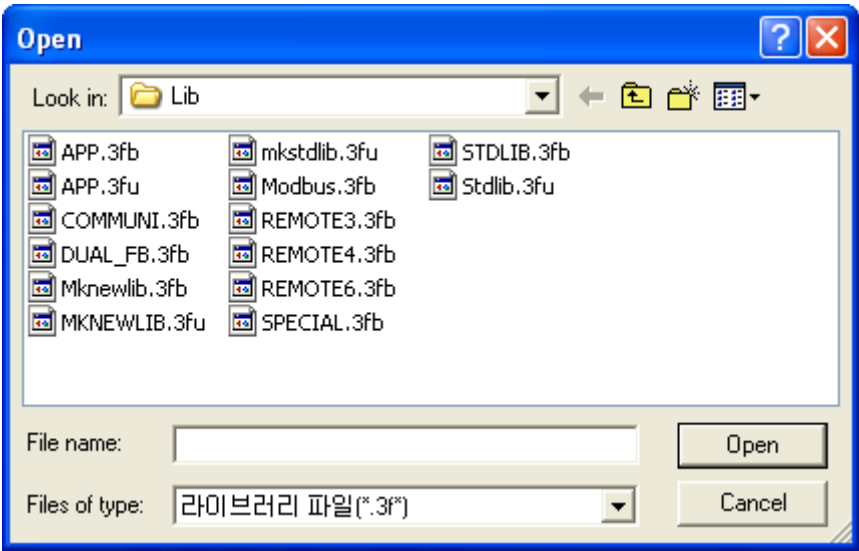

2) Insert the *Function Block* into GMWIN scan program and set the *Function Block* I/O variable. For the *Function Block* type and the method to use, please refer to Chapter 8.4. *Function Block*.

- RTU_WR
- RTU_RD

(2) In case of GM7 is the master,

(a) Communication parameter setting

1) Open the new project file in GMWIN.

- a) Select 'GM7' as PLC type.
- b) Create new project file for the master and the slave, respectively.

2) Select communication parameter from GMWIN parameter and double-click and the following figure will appear.

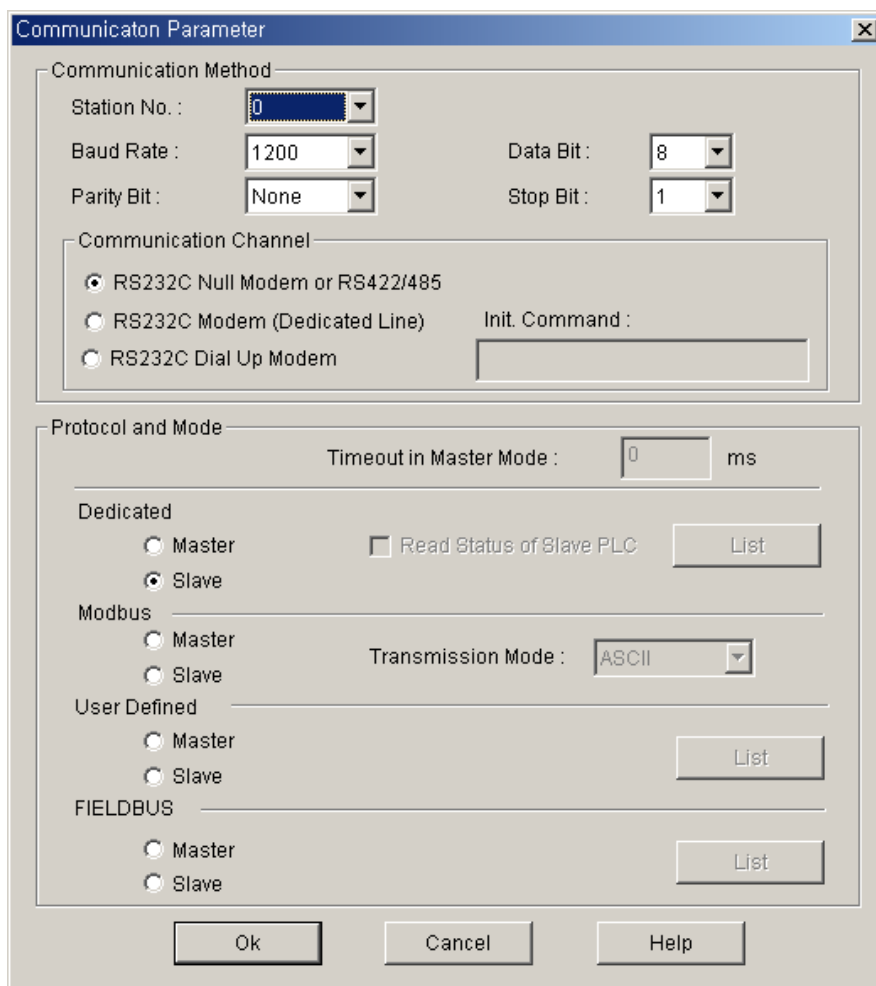

3) Set the contents as follows.

Items		Setting Description
Communication type	Self station no.	Available to set 1~31 stations. (do not set station 0 as broadcast station no. It may cause the failure.)
	Communication speed	Available to set 2400, 4800, 9600, 19200, 38400 bps.
	Data bit	Available to set as 7 or 8 bits. ASCII mode: set as 7 bits. RTU mode: set as 8 bits.
	Parity bit	Available to set as None, Even, Odd.
	Stop bit	Available to set as 1 or 2 bits. In case that the parity bit is set: set as 1 bit. In case that the parity bit is not set: set as 2 bits.
	Communication channel	<ul style="list-style-type: none"> • RS-232C null modem or RS422/485 : when communicating using GM7 basic unit and Cnet I/F module (G7L-CUEC). • RS-232C dedicated modem : when communicating by the dedicated modem using Cnet I/F module (G7L-CUEB). • RS-232C dialup modem : when communicating by the general modem connecting with other station by the phone using Cnet I/F module (G7L-CUEB). <p>Note) RS-232C exclusive modem and RS-232C dialup modem communication is done only by Cnet I/F module (G7L-CUEB) that supports RS-232C but not by Cnet I/F module (G7L-CUEC) that supports RS-422/485.</p>
Protocol and Transmission mode	Time out when setting the master	<ul style="list-style-type: none"> • This is the time to wait the response frame after sending the request frame from GM7 basic unit set as the master. • Default value is 500ms. • When setting, max. sending/receiving period of master PLC should be considered. • If the value smaller than max. sending/receiving period is set, it may cause the communication error.
	Modbus master / slave	If setting as the master, it shall be the subject in the communication system and if setting as the slave, it will reply only according to the request frame of the master.
	Transmission mode	Available to select one from ASCII mode or RTU mode.

8.3.2 MASTER-K series

(1) K80S modbus communication

(a) Communication parameter setting

1) Open new project file in KGLWIN.

- a) Select MK80S as PLC type.
- b) Create new project file for the master and the slave respectively.

2) Select communication parameter from KGMWIN parameter and doubleclick, and the following figure will appear.

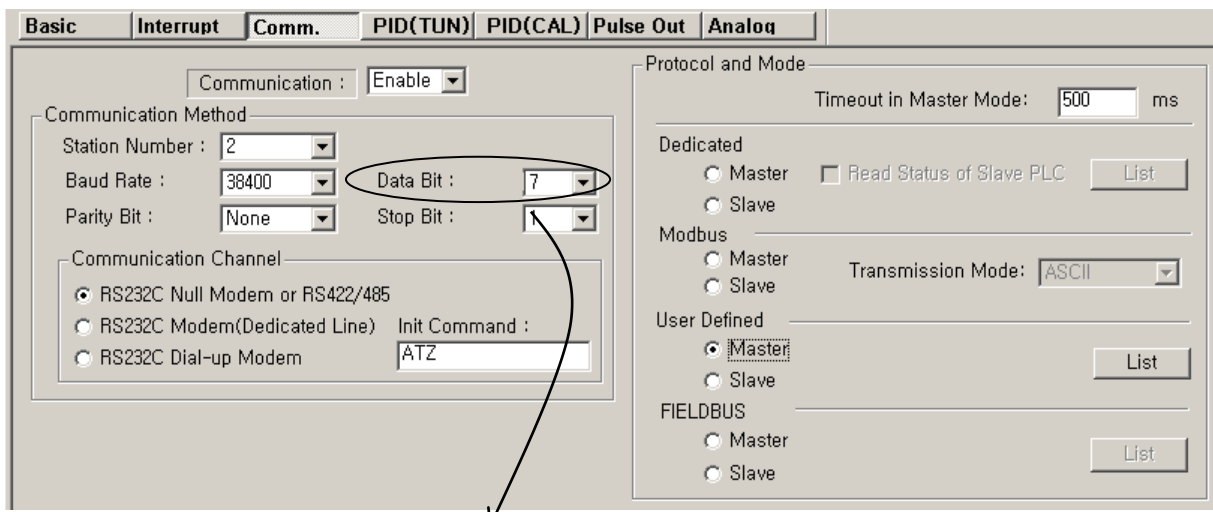

When transmission mode is

3) Set the contents as follows: mode set as 7 bits

Items		Setting Description
Communication type	Self station no.	Available to set 1~31 stations. (do not set station 0 as broadcast station no. It may cause the failure.)
	Communication speed	Available to set 2400, 4800, 9600, 19200, 38400 bps.
	Data bit	Available to set as 7 or 8 bits. ASCII mode : set as 7 bits. RTU mode : set as 8 bits.
	Parity bit	Available to set as None, Even, Odd.
	Stop bit	Available to set as 1 or 2 bits. When the parity bit is set : set as 1 bit. When the parity bit is not set : set as 2 bits.

Items		Setting Description
Protocol and Transmission mode	Communication channel	<ul style="list-style-type: none"> • RS-232C null modem or RS-422/485 : when communicating using MK80S basic unit and Cnet I/F module (G7L-CUEC). • RS-232C dedicated modem : when communicating by the dedicated modem using Cnet I/F module (G7L-CUEB). • RS-232C dialup modem : when communicating by the general dialup modem using Cnet I/F module (G7L-CUEB). <p>Note) RS-232C dedicated modem and RS232C dialup modem communication is done by Cnet I/F module (G7L-CUEB) only that supports RS-232C and not by Cnet I/F module (G7L-CUEC) that supports RS-422/485.</p>
	Timeout when setting the master	<ul style="list-style-type: none"> • This is the time to wait the response frame after sending the request frame from MK80S basic unit set as the master. • Default value is 500ms. • When setting, max. sending/receiving period of master PLC should be considered. • If the value smaller than max. sending/receiving period is set, it may cause the communication error.
	Modbus master /Slave	If setting as the master, it shall be the subject in the communication system and if setting as the slave, it will reply only according to the request frame of the master.
	Transmission mode	Available to select one from ASCII mode or RTU mode.

Remark

1) Modbus master communication of MASTER-K series operates only at the K80S and K120s K1000S/300/200S don't support Modbus master communication.

8.3.3 XGT series

When using XGT Cnet I/F module as client and executing Modbus communication, set each parameter through XG5000.

(1) Basic parameter setting method in the XG5000

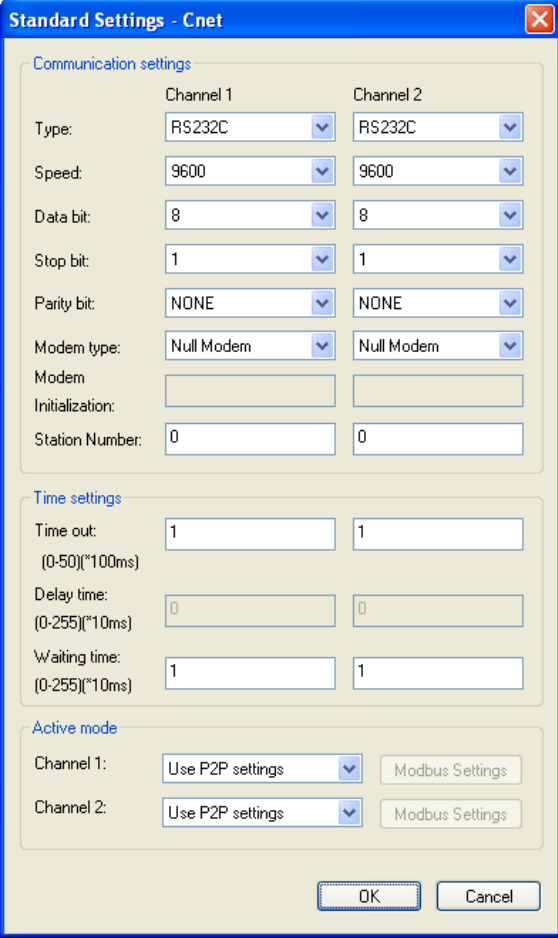
Sequence	Setting process	Setting method
1	I/O information reading	1. After online connecting, select [Online]-[Diagnosis]-[I/O Information]-[I/O Sync] and read information of module which is equipped at the current base.
2	Basic setting	
		<p>1. Connect by double-clicking the module you want to use.</p> <p>(1) Modbus RTU protocol: set data bit as 8.</p> <p>(2) Modbus ASCII protocol: set data bit as 7.</p> <p>2. select "Use p2p settings" in Active mode.</p>

(2) P2P parameter setting method in the XG5000**(a) P2P service**

P2P service is used when communication module operates as client and P2P function (command) is different according to protocol. P2P function is set as WRITE/READ when it operates as modbus RTU/ASCII. When P2P function is set as WRITE, it write data in the Smart I/O module which operate as a server and when READ, it read data from the Smart I/O module which operates as a server. P2P service can be set up to Max. 8 and each service consists of Max. 64. The following figure is parameter setting example.

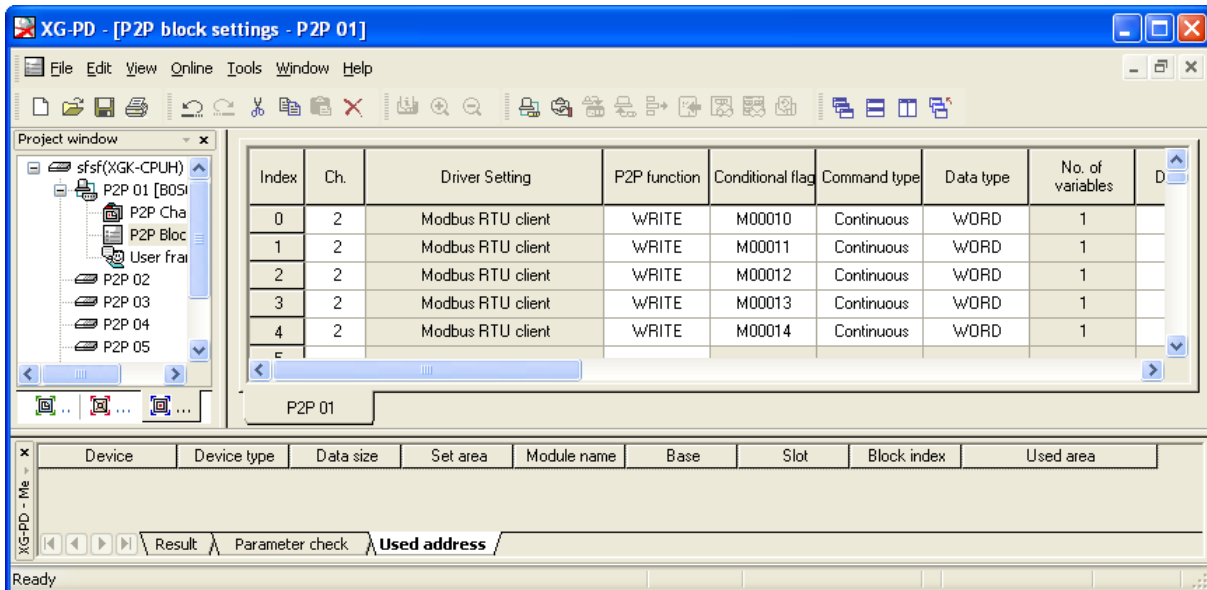

1) P2P parameter setting window

- a) Max. 8 P2P parameter can be set.
- b) It is available to set many P2P parameter per one Cnet I/F module.
But only one enable among P2P parameter is available about Cnet I/F module.
- c) Each P2P parameter consist of P2P channel, P2P block, user frame definition.

2) P2P edit window

- a) Max. up to 64 P2P block can be registered and edited.

In order to use P2P service, the user set for the wanted action in the P2P parameter window. P2P parameter consists of 3 category.

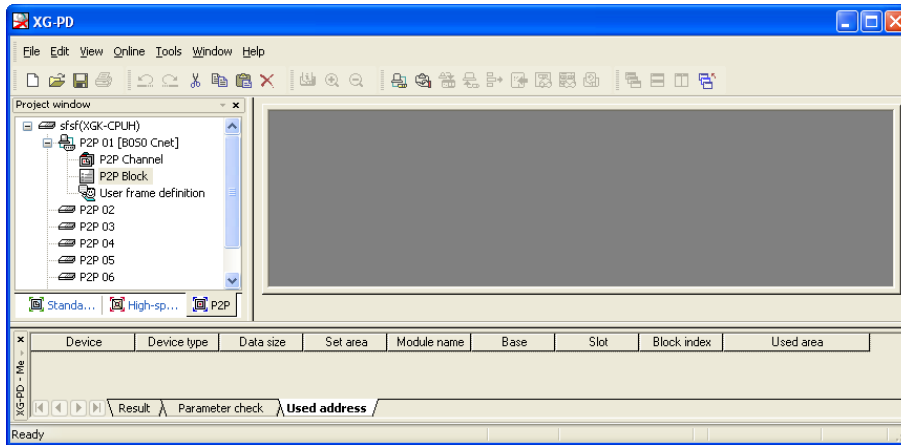

- 1) P2P channel
 - a) Set the P2P channel which defines P2P service's communication protocol.
 - b) Support protocol: XGT/Modbus client, user frame definition
 - c) Set it per channel. It is applied when basic setting's run mode is "Use P2P settings"
- 2) P2P block: set 64 P2P blocks which operate independently.
- 3) User frame definition: register user definition frame

(2) P2P channel setting

Cnet I/F module provide two communication channels (channel 1, 2) which operate independently.

About each channel, you can set driver type for P2P service. But when P2P channel is client, you should set run mode as "Use P2P settings". P2P channel setting according to operating mode is as follows.

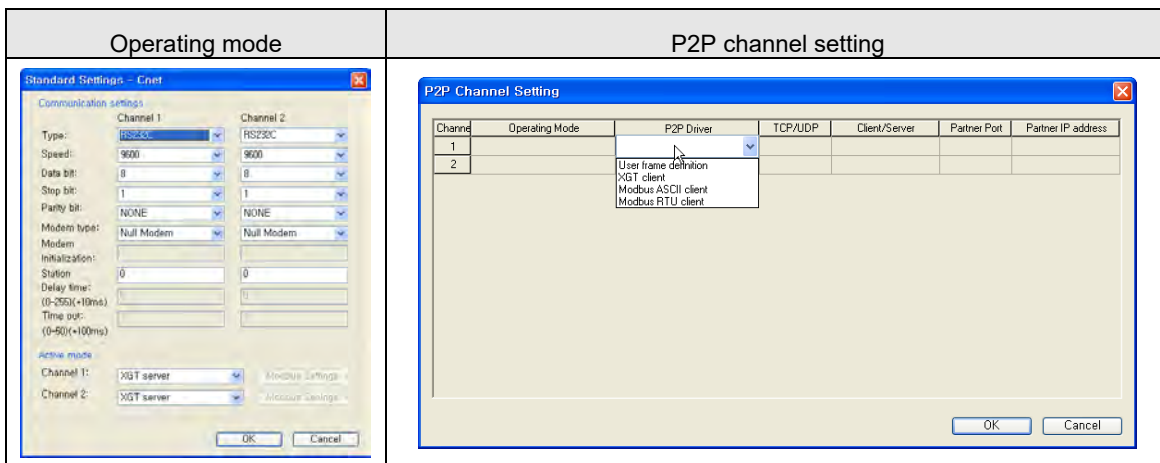





When setting as “Use P2P settings” in operating mode, the available driver in the XGT Cnet and meaning is as follows.

Driver	Meaning
User frame definition	It is used when transmitting and receiving desirable user definition frame.
XGT client	Select when you read and write by using XGT dedicated protocol.
Modbus ASCII client	Select when it operated as modbus client and ASCII mode.
Modbus RTU client	Select when it operated as modbus client and RTU mode.

[Table 7.2.1] driver table

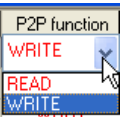
(3) P2P setting for using Smart I/O Snet

Modbus RTU/ASCII client’s action is divided into Read and Write. Modbus RTU’s setting method is same with ASCII client’s setting method.

P2P block settings - P2P 03											
Index	Channel	Driver Setting	P2P function	Conditional	Command type	Data type	No. of varia	Data size	Desti	Destination	Setting
0	2	Modbus RTU client	WRITE	M00010	Continuous	WORD	1	4	<input checked="" type="checkbox"/>	1	Setting
No.	Type	Block type	Description								
1	Channel		Setting driver name is changed according to the driver which is set in the P2P driver.								
2	P2P function		1. Read : reads data from other station. 2. Write : writes data at the other station.								
3	Conditional flag		1. select when to transmit or receive the data by using special flag or bit point. 2. In case of XGK type: F90 (operate every 20ms), M01 3. In case of XGI type: _T20MS (operate every 20ms), %MX01								
4	Command type		1. Single: is used when reading or writing data of max. 4 memory area. (example: M01, M10, M20, M30) 2. Continuous: is used when reading or writing data continuously. (example: M01~M10)								
5	Data type		Data type can be selected as Bit or Word.								

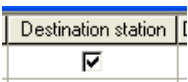
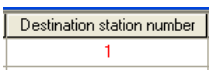
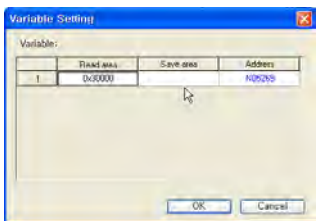
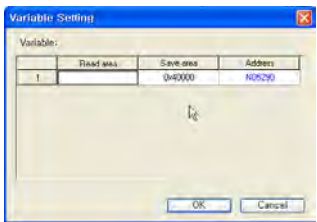
No.	Type	Block type	Description
6	Data size		<p>► It define data size and it is activated when continuous method.</p> <p>1. when P2P function is Read</p> <p>(1) modbus RTU client</p> <p>(a) bit type: 1~2000</p> <p>(b) word type: 1~125</p> <p>(2) modbus ASCII client</p> <p>(a) bit type: 1~976</p> <p>(b) word type: 1~61</p> <p>2. when P2P function is Write</p> <p>(1) modbus RTU client</p> <p>(a) bit type: 1~1968</p> <p>(b) word type: 1~123</p> <p>(2) modbus ASCII client</p> <p>(a) bit type: 1~944</p> <p>(b) word type: 1~125</p>
7	Destination station		It is checked automatically and if you don't want to use this function, click the box and cancel the check.
8	Destination station number		It means other station's address and the range is 0~31 total 32 station.
9	Setting		<p>► When P2P function is Read</p> <p>1. Read area: start address of other station's data area</p> <p>(1) bit: bit input (0x00000), bit output (0x10000)</p> <p>(2) word: word input (0x30000), word output (0x40000)</p> <p>2. Save area: data writing area at the self station (client)</p>
			<p>► When P2P function is Write</p> <p>1. Read area: data area of self station</p> <p>2. Save area: start address of other station's data area</p> <p>(1) bit: bit input (0x00000), bit output (0x10000)</p> <p>(2) word: word input (0x30000), word output (0x40000)</p>

(4) Basic setting and P2P parameter writing

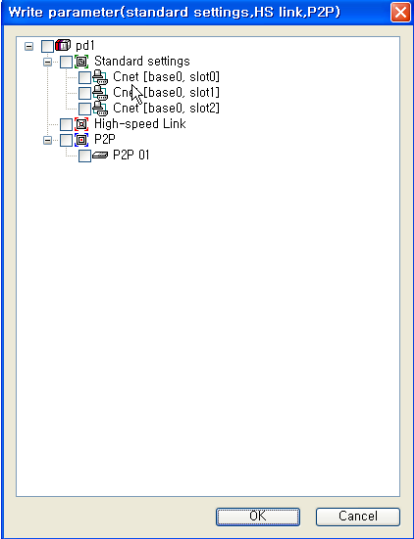
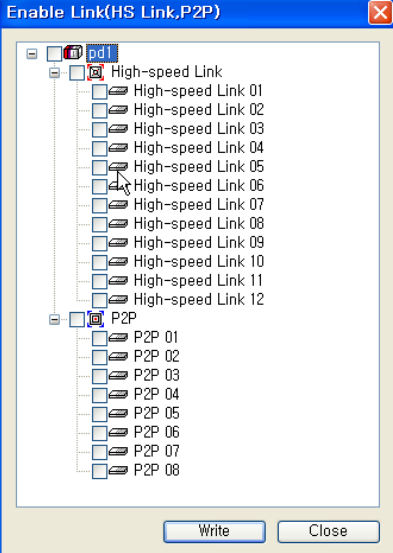
Sequence	Setting process	Setting method
1	Write Parameter	
<ol style="list-style-type: none"> 1. Click parameter writing in online menu. 2. Check the module where basic is set and P2P parameter and click OK. 3. Communication module is reset automatically. 		
2	Enable Link	
<ol style="list-style-type: none"> 1. Click link enable in online menu. 2. Check P2P parameter and click Write. 		

8.4 Function Block

8.4.1 GLOFA-GM Series

(1) For GM3/4/6

(a) RTU_RD

Item	IN / OUT	Type	Description						
	REQ	BOOL	Function Block execution condition (Rising edge action) - When changing from 0 to 1, one time executed.						
	SLOT	USINT	Cnet module slot no. (0 ~ 7)						
	CH	USINT	Channel setting (0 : RS-232C, 1 : RS-422/485)						
	STN	USINT	Other station no. setting (0 ~ 32)						
	CMND	USINT	Modbus Command (1 ~4) 1 : Read coil status (Bit) 2 : Read input status (Bit) 3 : Read holding register (Word) 4 : Read input register (Word)						
	ADDR	INT	Leading address of other station to Read (1 ~ 9999)						
	NUM	USINT	Data number to Read (1 ~ 64)						
	RES_WAIT	TIME	Response wait time (after the setting wait time, receive the response data from Cnet module of CPU.)						
	NDR	BOOL	After completing the normal communication, 1 Scan 'ON'.						
	ERR	BOOL	When communication error occurs, 1 Scan 'ON'.						
	STATUS	USINT	Communication status code (Error code) 0 : normal, if not 0, : Error code						
	DATA	USINT ARRY (256)	Receiving data storage area <table border="1" style="margin-left: 20px;"> <tr><td>Array [0] : High Byte of first word</td></tr> <tr><td>Array [1] : Low Byte of first word</td></tr> <tr><td>Array [2] : High Byte of second word</td></tr> <tr><td>Array [3] : Low Byte of second word</td></tr> <tr><td style="text-align: center;">...</td></tr> <tr><td>Array [3] : Low Byte of 256 word</td></tr> </table>	Array [0] : High Byte of first word	Array [1] : Low Byte of first word	Array [2] : High Byte of second word	Array [3] : Low Byte of second word	...	Array [3] : Low Byte of 256 word
	Array [0] : High Byte of first word								
Array [1] : Low Byte of first word									
Array [2] : High Byte of second word									
Array [3] : Low Byte of second word									
...									
Array [3] : Low Byte of 256 word									

1) Function

This is the *Function Block* that is executed by selecting function code 01, 02, 03, 04 from modbus protocol communication and used for Bit/Word Read. Function code 01 executes output contact status (Coil Status) Data Read and function code 02 executes input contact status (Input Status) Data Read. Function code 03 executes output register (Holding Registers) Data Read and function code 04 executes input register (Input Registers) Data Read.

2) Error

Output the error code from output STATUS. For further information, please refer to error code.

Remark

Response Wait Time setting

- 1) After the setting wait time, receive the response data from Cnet module of CPU.
- 2) If the response does not reach from other station within the setting time, error (code 74 or code 10) occurs. This *Function Block* acts in Cnet function '**User Definition Mode**'.
- 3) Response Wait Time shall be set considering Read/Write data number, transmission speed (Baudrate), the response speed of other station etc.
- 4) When setting, please refer to the table below and if error occurs, extend the setting time.

Classification	1 ~ 16 word	17 ~ 32 word	33 ~ 48 word	49 ~ 64 word
4800 bps	150ms	250ms	330ms	400ms
9600 bps	100ms	180ms	230ms	280ms
19200 bps	80ms	150ms	180ms	230ms

(b) RTU_WR

Item	IN / OUT	Type	Description					
	REQ	BOOL	<i>Function Block</i> execution condition (Rising edge action) - When changing from 0 to 1, one time executed.					
	SLOT	USINT	Cnet module slot no. (0 ~ 7)					
	CH	USINT	Channel setting (0 : RS-232C, 1 : RS-422/485)					
	STN	USINT	Other station no. setting (0 ~ 32)					
	CMND	USINT	Modbus function code (15 ~ 16) 15 : Force Multiple coils(Bit) 16 : Preset Multiple register (Word)					
	ADDR	INT	Leading address to Write (1 ~ 9999)					
	NUM	USINT	Data number to Write (1 ~ 64)					
	RES_WAIT	TIME	Response wait time (after the setting wait time, receive the response data from Cnet module of CPU.)					
	NDR	BOOL	After completion of the normal communication, 1 Scan 'ON'.					
	ERR	BOOL	When communication error occurs, 1 Scan 'ON'.					
	STATUS	USINT	Communication status code (Error code) 0 : normal, if not 0: Error code					
	DATA	USINT ARRY (256)	Self station data storage area to Write <table border="1" style="margin-left: 20px;"> <tr><td>Array [0] : High Byte of first word</td></tr> <tr><td>Array [1] : Low Byte of first word</td></tr> <tr><td>Array [2] : High Byte of second word</td></tr> <tr><td>Array [3] : Low Byte of second word</td></tr> <tr><td style="text-align: center;">...</td></tr> </table>	Array [0] : High Byte of first word	Array [1] : Low Byte of first word	Array [2] : High Byte of second word	Array [3] : Low Byte of second word	...
	Array [0] : High Byte of first word							
Array [1] : Low Byte of first word								
Array [2] : High Byte of second word								
Array [3] : Low Byte of second word								
...								

1) Function

This is the *Function Block* to execute by selecting function code 15 and 16 from modbus protocol communication and used for Continuous 1 bit Write (function code 15), Continuous 1 word Write (function code 16). Function code 15 performs 1 bit Data Write to output contact (Coil) continuously and function code 16 performs 1 word Data Write to output register (Holding Registers) continuously.

2) Error

Output the error code to output STATUS. For further information, please refer to the error code.

Remark
<p>1) This <i>Function Block</i> acts in Cnet function 'User Definition Mode'.</p> <p>2) Basic parameter (Baudrate, Data bit, Stop bit, Parity check, Station No. etc.) shall be set in Cnet editor and the frame editing is not needed.</p> <p>3) This supports Modbus RTU Protocol. (scheduled to support ASCII Protocol later)</p> <p>4) Cnet module requirements to use this <i>Function Block</i> are as follows.</p> <ul style="list-style-type: none"> - Cnet module version : more than v2.0 (available to verify in GMWIN) - Cnet module Flash Rom OS version : more than v1.01 (available to verify in Cnet Editor) - Modbus.Nfb (Modbus <i>Function Block</i> file, N=3,4,6) needed.

Error code table

Status code (Dec)	Description	Solution	Remarks
0	Normal	No error	
1	Illegal function code (When the master requires the command that the Slave does not support.)	After confirming the command available to support by the Slave, modify the command on FB.	The error returned from the Slave
2	Illegal address (When the Master requires the address that the Slave does not support.)	After confirming the address available to support by the Slave, modify the address on FB.	
3	Illegal data value (When the Master requires the data of the range that the Slave does not support.)	After confirming the data range available to support by the Slave, modify the data on FB.	
4	Slave device failure (The unrecoverable error occurs while performing the Master requirements in the Slave.)	Check the Slave station status.	
6	Slave device busy	After waiting for the regular time, Master	Function Block setting error
10	Receiving Frame CRC error	1. After confirming the receiving frame status, extend the Response Wait Time. 2. Check the Cable and Noise status.	
16	Cnet module I/F error (No Cnet module in the designated slot.)	Check the slot no. designated on FB.	
64	Channel (RS-232C/422) stop	RUN the Cnet module. (power reinput)	
74	Time out error	1. Check the basic parameter (station no./speed etc.) 2. Check the Slave station status (power etc.) 3. Check the Cable status and disconnection	
115	Communication mode error	Check if Cnet user definition	

(2) For GM7

(a) MOD0102 (reading bit)

Function Block	Description
	<p>Input</p> <p>REQ : When 1 (rising edge), <i>Function Block</i> execution</p> <p>SLV_ADDR : Input of Slave station number</p> <p>FUNC : Function code input It supports function code 01 and 02.</p> <p>ADDRH : High address of starting address to read in the Slave station.</p> <p>ADDR_L : Low address of starting address to read in the Slave station.</p> <p>NUMH : High address of data size to read from the starting address to read in the Slave station.</p> <p>NUM_L : Low address of data size to read from the starting address to read in the Slave station.</p> <p>Output</p> <p>RD_DATA : Variable name to save the Read data. (Array number should be declared as equal to or greater than the data size.)</p> <p>NDR : If executing without error, output 1 and maintain 1 until calling next <i>Function Block</i>.</p> <p>ERR : When error occurs, output 1 and maintain 1 until calling next <i>Function Block</i>.</p> <p>STATUS : When error occurs, output the error code.</p>

1) Function

This is the *Function Block* to execute by selecting function code 01 and 02 from modbus protocol communication and used for Bit Read. Function code 01 performs output contact status (Coil status) data Read and function code 02 performs input contact status (Input Status) data Read.

2) Error

Output the error code to the Output STATUS. For further information, please refer to the error code.

a) Program Example

This is the example when GM7 basic unit is the Master and when reading output contact data of Modicon product that is station no.17.

- Execute the Status Read of output contact (Coil) 00000 ~ 00010 of the Slave station (Station no.17). The output contact of the Slave station is assumed as follows and the read data is saved in the BOOL type random array variable RD_DB0 whose size is 16.

Output contact	15	14	13	12	11	10	9	8	7	6	5	4	3	2	1	0
Contact status	1	1	1	1	0	0	0	1	1	1	1	0	0	1	1	0
Hex	F				1				E				6			

<Data status of Smart I/O 16 point output module 'contact (00000~00009)>

- The data shall be transmitted from low bit by byte unit. The insufficient bit part of the byte shall be filled with '0'. The transmission of the above data is shown on Ex.1).

Ex.1) E6 F1

Function Block	Input value	
REQ	Enter the input condition to run.	
SLV_ADDR	16#11 or 17	Slave station no.
FUNC	16#01 or 1	Enter '1' when reading output contact status.
ADDRH	16#00 or 0	High byte among the address starting to read from the Slave station.
ADDRL	16#FF or 255	Low byte among the address starting to read from the Slave station. - In order to read from output contact 00000, it is required to read from no. 255 according to the 8) modbus addressing regulation. And most significant data in its address shall be processed automatically by the input value of 'FUNC' without a separate input.
NUMH	16#00 or 0	High byte when expressing total size of data to read by Hexadecimal.
NUML	16#0A or 10	Low byte when expressing total size of data to read by Hexadecimal. - From the example, it is required to read 00000 ~ 00010 and total size of data shall be 10. If expressing 10 by Hexadecimal, it shall be H000A and it is required to enter H00 for NUMH and H0A for NUML .

● Results

Variable name	Storage value	Variable name	Storage value	Variable name	Storage value	Variable name	Storage value
RD_DB0[0]	0	RD_DB0[4]	0	RD_DB0[8]	1	RD_DB0[12]	X
RD_DB0[1]	1	RD_DB0[5]	1	RD_DB0[9]	0	RD_DB0[13]	X
RD_DB0[2]	1	RD_DB0[6]	1	RD_DB0[10]	X	RD_DB0[14]	X
RD_DB0[3]	0	RD_DB0[7]	1	RD_DB0[11]	X	RD_DB0[15]	X

- The variable to save the read data should be array type variable and the size of array type variable should be equal to or greater than that of the data to read. If it is smaller, error code shall be indicated on the STATUS.
- The read data shall be saved from array variable RD_DB0[0].
- The remaining part after filling the array variable by the read data shall be redundancy.

(b) MOD0304 (reading word)

Function Block	Description
	<p>Input</p> <p>REQ : When 1 (rising edge), <i>Function Block</i> execution</p> <p>SLV_ADDR : Slave station no. input</p> <p>FUNC : Function code input It supports function code 03 and 04.</p> <p>ADDRH : High address of starting address to read in the Slave station.</p> <p>ADDRL : Low address of starting address to read in the Slave station.</p> <p>NUMH : High address of data size to read from the starting address to read in the Slave station.</p> <p>NUML : Low address of data size to read from the starting address to read in the Slave station.</p> <p>Output</p> <p>RD_DATA : Variable name to save the Read data. (Array number should be declared as equal to or greater than the data size.)</p> <p>NDR : If executing without error, output 1 and maintain 1 until calling next <i>Function Block</i>.</p> <p>ERR : When error occurs, output 1 and maintain 1 until calling next <i>Function Block</i>.</p> <p>STATUS : When error occurs, output the error code.</p>

1) Function

This is the *Function Block* to execute by selecting function code 03 and 04 from modbus protocol communication and used for Word Read. Function code 03 performs output register (Holding Registers) data Read and function code 04 performs input register (Input Registers) data Read.

2) Error

Hold the error code to the Output STATUS. For further information, please refer to the error code.

a) Program Example

This is the example when GM7 basic unit is the Master and when reading output register data of Smart I/O 32 point output module that is station no.17.

- Execute the Read of output register (Holding Registers) 40000 ~ 40001 of the Slave station (Station no.17). The output register of the Slave station is assumed as follows and the read data is saved in the WORD type random array variable RD_DW0 whose size is 4.

Output Register	40000	40001
Register Status	H0064	H1234

- The data shall be transmitted from high byte of low word per byte unit. The transmission of the above data is shown on Ex.1).

Ex.1) 12 34 00 64

Function Block input	Input value
REQ	Enter the input condition to run.
SLV_ADDR	16#11 or 17 : Slave station no.
FUNC	16#03 or 3 : Enter '3' when reading output register.
ADDRH	16#00 or 0 : High byte among the address starting to read from the Slave station.
ADDRL	16#FF or 255 : Low byte among the address starting to read from the Slave station. - In order to read from output register 40000, it is required to read from no.255 according to the 8) modbus addressing regulation. And the most significant data in its address shall be processed automatically by the input value of 'FUNC' without a separate input.
NUMH	16#00 or 0 : High byte when expressing total size of data to read by Hexadecimal.
NUML	16#02 or 2 : Low byte when expressing total size of data to read by Hexadecimal. - From the example, it is required to read 40000 ~ 40001 and total sizes of data shall be 2. When expressing 2 by Hexadecimal, it shall be H0002 and it is required to enter H00 for NUMH and H02 for NUML.

● Results

Variable name	Storage value
RD_DW0[0]	H1234 or 4660
RD_DW0[1]	H0064 or 100
RD_DW0[2]	X
RD_DW0[3]	X

- The variable to save the read data should be array type variable and the size of array type variable should be equal to or greater than that of the data to read. If it is smaller, error code shall be indicated on the STATUS.
- The read data shall be saved from array variable RD_DW0[0].
- The remaining part after filling the array variable by the read data shall be redundancy.

(c) MOD0506 (writing 1bit/1word)

Function Block	Description
	<p>Input</p> <p>REQ : When 1 (rising edge), <i>Function Block</i> execution</p> <p>SLV_ADDR : Slave station address input</p> <p>FUNC : Function code input It supports function code 05 and 06.</p> <p>ADDRH : High address among start address to write in the Slave station.</p> <p>ADDR : Low address among start address to write in the Slave station.</p> <p>NUMH : High address among data to write in the Slave station.</p> <p>NUML : Low address among data to write in the Slave station.</p> <p>Output</p> <p>NDR : If executing without error, output 1 and maintain 1 until calling next <i>Function Block</i>.</p> <p>ERR : When error occurs, output 1 and maintain 1 until calling next <i>Function Block</i>.</p> <p>STATUS : When error occurs, output the error code.</p>

1) Function

This is the *Function Block* to execute by selecting function code 05 and 06 from modbus protocol communication and used for 1 Bit Write (function code 05) and 1 Word Write (function code 06). Function code 05 performs 1Bit data Write for output contact (Coil) and if setting 255 (or HFF) for input NUMH of *Function Block* or 0 (or H00) for input NUML, write '1' for output contact and if setting 0 (or H00) for input NUMH or 0 (or H00) for NUML, write '0' for output contact. Function code 06 performs 1 word data write in output register.

2) Error

Output the error code to the output STATUS. For further information, please refer to Error code.

a) Program Example

- ▶ This is the example when GM7 basic unit is the Master and when writing 1 bit data to the 16 point output contact of smart I/O that is station no.17.
 - Write '1' to the output contact (Coil) 00000 of the Slave station (station no.17)

Function Block input	Input value
REQ	Enter the input condition to run.
SLV_ADDR	16#11 or 17 : Slave station no.
FUNC	16#05 or 5 : Enter '5' when writing 1 Bit to output contact.
ADDRH	16#00 or 0 : High byte among the address starting to write in the Slave station.
ADDRL	16#FF or 255 : Low byte among the address starting to write in the Slave station. - In order to write to output contact 00000, it is required to write from No.255 according to the 8) modbus addressing regulation. And most significant data of data address shall be processed automatically by the input value of FUNC without a separate input.
NUMH	16#00 or 0 : Data to write in the Slave station
NUML	16#00 or 0 : Data to write in the Slave station - From the example, it is required to write '1'. Thus, enter H00 for NUMH and H01 for NUML.

- Results: Output contact 00000 shall be ON. (In case of GM7 basic unit, '1' shall be saved in the corresponding M area.)

Output contact	00000
Contact status	1

- ▶ This is the example when GM7 basic unit is the Master and when writing 2 Word Data to the 32 point output contact of smart I/O that is station no.17.
- This is the example to write '3' to the output register (Holding Registers) 40000 of the Slave station (Station no.17).

Function Block input	Input value
REQ	Enter the input condition to run.
SLV_ADDR	16#11 or 17 : Slave station no.
FUNC	16#06 or 6 : Enter '6' when writing 1 Word to output register.
ADDRH	16#00 or 0 : High byte among the address starting to write in the Slave station.
ADDRL	16#FF or 255 : Low byte among the address starting to write in the Slave station. - In order to write to output contact 40000, it is required to write from No.255 according to the 8) modbus addressing regulation. And most significant data of its address shall be processed automatically by the input value of 'FUNC' without a separate input.
NUMH	16#00 or 0 : High byte when expressing the data to write in the Slave station by Hexadecimal.
NUML	16#03 or 3 : Low byte when expressing the data to write in the Slave station by Hexadecimal. - From the example, it is required to write '3' and if expressing the data by Hexadecimal, it shall be H0003 and it is required to enter H00 for NUMH and H03 for NUML.

- Results: H0003 shall be saved in output register 40000. (In case of GM7 basic unit, H0003 shall be saved in the corresponding M area.)

Output register	40000
Register status	H0003

(d) MOD1516 (writing 1 bit/1 word continuously)

Function Block	Description
	<p>Input</p> <p>REQ : When 1 (rising edge), <i>Function Block</i> execution</p> <p>SLV_ADDR : Slave station address input</p> <p>FUNC : Function code input It supports function code 15 and 16.</p> <p>ADDRH : High address among starting address to write in the Slave station.</p> <p>ADDRL : Low address among starting address to write in the Slave station.</p> <p>NUMH : High address of data size to write in the Slave station.</p> <p>NUML : Low address of data size to write in the Slave station.</p> <p>BYTE_CNT : Byte size of data to write in the Slave station.</p> <p>WR_DATA : Variable name to save the data to write. (It should be declared as equal to or greater than the data size.)</p> <p>Output</p> <p>NDR : If executing without error, output 1 and maintain 1 until calling next <i>Function Block</i>.</p> <p>ERR : When error occurs, output 1 and maintain 1 until calling next <i>Function Block</i>.</p> <p>STATUS : When error occurs, output the error code.</p>

1) Function

This is the *Function Block* to execute by selecting function code 15 and 16 from modbus protocol communication and used for Continuous 1Bit Write (function code 15) and Continuous 1Word Write (function code 16). Function code 15 performs 1Bit Data Write for output contact (Coil) by 1 byte continuously and Function code 16 performs 1 Word Data Write for output register (Holding Registers) continuously.

2) Error

Output the error code to the output STATUS. For further information, please refer to Error Code.

a) Program Example

- ▶ This is the example when GM7 basic unit is the Master and when writing Bit Data continuously to 16 point output contact of Smart I/O that is station no.17.
- It writes the continued 10bit 10101010101010 to output contact (Coil) 00000 in the Slave station (Station no.17) by 1bit. The data to write is saved in BYTE type random array variable WR_DB0 whose size is 2.

Variable name	Storage value
WR_DB0[0]	2#01010101 or 16#55
WR_DB0[1]	2#01010101 or 16#55

- The data shall be transmitted by byte unit from low bit. The transmission of the above data is shown on Ex.1).

Ex.1) 55 55

Function Block input	Input value
REQ	Enter the input condition to run.
SLV_ADDR	16#11 or 17 : Slave station no.
FUNC	16#0F or 15 : Enter '15' when writing Bit to output contact continuously.
ADDRH	16#00 or 0 : High byte among starting address to write in the Slave station.
ADDRL	16#FF or 255 : Low byte among starting address to write in the Slave station. - In order to write from output contact 00020, it is required to write from No.255 according to the 8) modbus addressing regulation. And the most significant data of data address shall be processed automatically by the input value of 'FUNC' without separate input.
NUMH	16#00 or 0 : High byte when expressing total size of data to write in the Slave station by Hexadecimal.
NUML	16#0F or 16 : Low byte when expressing total size of data to write in the Slave station by Hexadecimal. - From the example, it is the 16 bit data continued from 00000 and total size shall be 16. If expressing 16 by Hexadecimal, it shall be H000A and it is required to enter H00 for NUMH and H0A for NUML.
BYTE_CNT	16#02 or 2 : This is the size when converting total size of data to write in the Slave station by byte unit. - From the example, it is the continued 16 bit data and if converted by byte unit, it shall be 2 bytes. Thus, it is required to enter H02 for BYTE_CNT.

- Results

Output contact	15	14	13	12	11	10	9	8	7	6	5	4	3	2	1	0
Contact status	0	1	0	1	0	1	0	1	0	1	0	1	0	1	0	1

- ▶ This is the example when GM7 basic unit is the Master and when writing Bit Data continuously to 32 contact output module of Smart I/O that is station no.17.
- It writes 000A and 0102 to output register (Holding Registers) 40000 in the Slave station (station no.17). The data to write is saved in BYTE type array variable WR_DB1 whose size is 4.

Variable name	Storage value
WR_DB1[0]	2#00001010 or 16#0A
WR_DB1[1]	2#00000000 or 16#00
WR_DB1[2]	2#00000010 or 16#02
WR_DB1[3]	2#00000001 or 16#01

- The size of BYTE_CNT is the size when converting the data to write by byte unit. As the above data is 2 words, it is required to use 4 bytes. Thus, the size of BYTE_CNT is 4.
- The data is transmitted from low word by byte unit. The transmission of the above data is shown on Ex.1).

Ex.1) 00 0A 01 02

Function Block input	Input value
REQ	Enter the input condition to run.
SLV_ADDR	16#11 or 17 : Slave station no.
FUNC	16#0F or 16 : Enter '16' when writing Word to output register continuously.
ADDRH	16#00 or 0 : High byte among starting address to write in the Slave station.
ADDRL	16#FF or 255 : Low byte among starting address to write in the Slave station. - In order to write from output register 40000, it is required to write from No.255 according to the 8) modbus addressing regulation. And most significant data of data address shall be processed automatically by the input value of 'FUNC' without separate input.
NUMH	16#00 or 0 : High byte when expressing total size of data to write in the Slave station by Hexadecimal.
NUML	16#02 or 2 : Low byte when expressing total size of data to write in the Slave station by Hexadecimal. - From the example, it is the 2 word data continued from 40000 and total size shall be 2. If expressing 2 by Hexadecimal, it shall be H0002 and it is required to enter H00 for NUMH and H02 for NUML.

Function Block input	Input value
BYTE_CNT	16#04 or 4 : This is the size when converting total size of data to write in Slave station by byte unit. - From the example, it is the continued 2 word data and if converted by byte unit, it shall be 4 byte. Thus, it is required to enter H04 for BYTE_CNT.

● Results

Output register	40001	40000
Register status	H0102	H000A

e) Error code

CODE	Error type	Meaning
01	Illegal Function	Function code input error to the <i>Function Block</i>
02	Illegal Address	The area to read/write in the slave exceeds the allowed range.
03	Illegal Data Value	The data value to read/write in the Slave is not allowed.
04	Slave Device Failure	Slave error status
05	Waiting for Acknowledge	This is a kind of response code that the Slave sends to the master to prevent the time of the master when it takes a time for the processing of demand command. In the master, it indicates the error code and wait for the regular time without demanding again.
06	Slave Device Busy	The error caused by long processing time of the slave. Master must demand again.
07	Time Out Error	The error occurred when exceeding the setting time of the communication parameter while communication.
08	Data Size Error	The error occurred when data is '0' or more than 256byte, when data size is greater than array size, and when number and BYTE_CNT is different.
09	Parameter Error	Parameter setting error (mode, master/slave)
10	Station Error	The error occurred when the station no. set in self station and input parameter of function is the same.

8.4.2 MASTER-K Series

(1) Command Modbus

MODBUS command is available only in the K80S, K120S.

But in case of using the K120S, it is available to use communication port by only RS-232C.

Command	Available area to use												Step no.	Flag			
	M	P	K		L	F	T	C	S	D	#D	Integral number		Error (F110)	Zero (F111)	Carry (F112)	
Modbus	S1	0	0	0	0	0	0	0	0	-	0	0	-	7	0	-	-
	S2	0	0	0	0	0	-	0	0	-	0	0	-				
	S3	0	0	0	0	0	-	0	0	-	0	0	-				

	Flag	
	F110	When exceeding #D area, it shall be ON.
	Area setting	
	S1	Device address to register sending/receiving parameter. (3 words)
	S2	Device address to save sending/receiving data. (1 word)
S3	Device address to indicate sending/receiving status. (1 word)	

(a) Function

1) Here sets data saved in device designated in S1 to fit Modbus protocol type.

It consist of 3 words and must be set by Hexdecimal code.

a) first word : slave station address (high byte) + function code (low byte)

b) second word : means Smart I/O's IO address (h0000).

c) third word

▶ When Smart I/O is output module: device address where data for tansmission is saved.

▶ When Smart I/O is input module: data number for reading

d) This designates the leading address of the device where the received data is saved to S2.

➔ According to function of S1, it designates the leading address of the device that the received data is saved in when receiving and the leading address of the data to sending when sending.

e) The communication action status is saved in S3.

(b) error code

1) S3 (sending/receiving status)'s format is as follows.

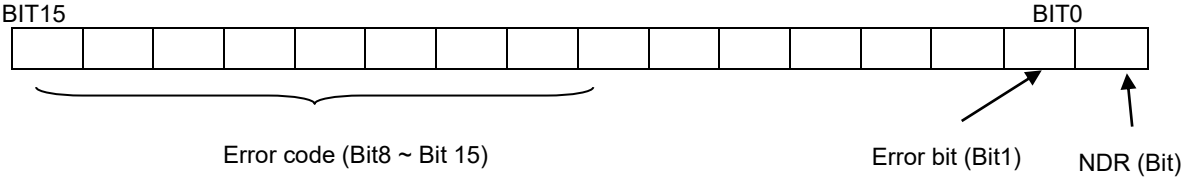

- 2) NDR : when completing the normal communication, 1 Scan ON.
- 3) Error bit : when communication error occurs, 1 Scan ON and in this case, error code is indicated Bit8 ~ Bit15.
- 4) Error code : when error occurs, it shows the information for the error.
(refer to the error code table as below.)

Error code table

Code	Name	Description
01	Illegal Function	Function code error
02	Illegal Address	Address allowed range exceeded
03	Illegal Data Value	The error that data value is not allowed.
04	Slave Device Failure	Slave error status
05	Waiting for Acknowledge	When it takes a time for the processing of demand command, the slave sends to prevent Time Out Error of the master.
06	Slave Device Busy	The slave takes a time for the processing. The master must demand again.
07	Time Out Error	When no response during Time out of communication parameter.
08	Data Size Error	When data size is '0' or exceeds 256Byte. In case of data size is larger than Array size or Number and BYTE_CNT is different.
09	Parameter Error	When the items set in the parameter (such as transmission mode etc.) are wrong.
10	Station Error	When self station no. and input parameter of Modbus command are the same.

(2) Command MODCOM

It is available to use MODCOM command only in the K120S.

Command	Available area to use												Step no	Flag			
	M	P	K		L	F	T	C	S	D	# D	Integral number		Error (F110)	Zero (F111)	carry (F112)	
Modbus	CH	-	-	-	-	-	-	-	-	-	-	-	0	7	0	-	-
	S1	0	0	0	0	0	0	0	0	-	0	0	-				
	S2	0	0	0	0	0	-	0	0	-	0	0	-				
	S3	0	0	0	0	0	-	0	0	-	0	0	-				

	Flag	
	F110	When exceeding #D area, it shall be ON.
	Area setting	
	CH	Communication channel
	S1	Device address to register sending/receiving parameter.
	S2	Device address to save sending/receiving data.
S3	Device address to indicate sending/receiving status.	

(a) Function

- 1) CH means communication channel and is set as integral number.
 - a) 0 : set when using built-in RS-232C communication or extension communication module (G7L-CUEC)
 - b) 1 : set when using built-in RS-485 communication.
- 2) Here sets data saved in device designated in S1 to fit Modbus protocol type.

It consist of 3 word and must be set by Hexdecimal code.

 - a) first word : slave station address (high byte) + function code (low byte)
 - b) second word : means Smart I/O's IO address (h0000).
 - c) third word
 - ▶ When Smart I/O is output module: device address where data for transmission is saved.
 - ▶ When Smart I/O is input module: data No. for reading
- 3) This designates the leading address of the device where the received data is saved to S2.

➔ According to function of S1, it designates the leading address of the device that the received data is saved in when receiving and the leading address of the data to sending when sending.
- 4) The communication action status is saved in S3.

(b) error code

1) S3 (sending/receiving status)'s format is as follows

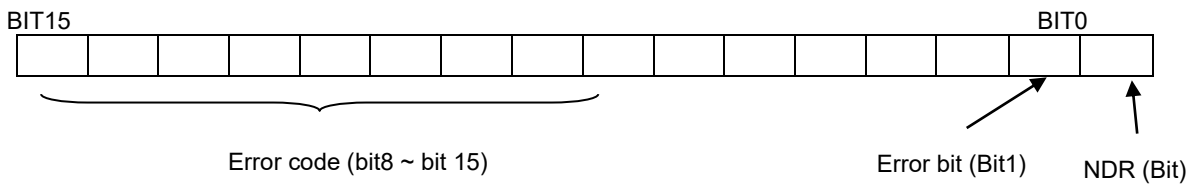

2) NDR : when completing the normal communication, 1Scan ON.

3) Error bit : when communication error occurs, 1Scan ON and in this case, error code is indicated Bit8 ~ Bit15.

4) Error code : when error occurs, it shows the information for the error.

(refer to the error code table as below.)

Error code table

Code	Name	Description
01	Illegal Function	Function code error
02	Illegal Address	Address allowed range exceeded
03	Illegal Data Value	The error that data value is not allowed.
04	Slave Device Failure	Slave error status
05	Acknowledge	When it takes a time for the processing of demand command, the slave sends to prevent time out of the master.
06	Slave Device Busy	The slave takes a time for the processing. The master must demand again.
07	Time Out Error	When no response during Time out of communication parameter.
08	Data Size Error	When data size is '0' or exceeds 256Byte. In case of data size is larger than Array size or Number and BYTE_CNT is different.
09	Parameter Error	When the items set in the parameter (such as transmission mode etc.) are wrong.
10	Station Error	When self station no. and input parameter of Modbus command are the same.

8.5 Program Example

8.5.1 GLOFA-GM Series

(1) When the Master is GM4

(a) Set the basic frame in Cnet module of Master PLC.

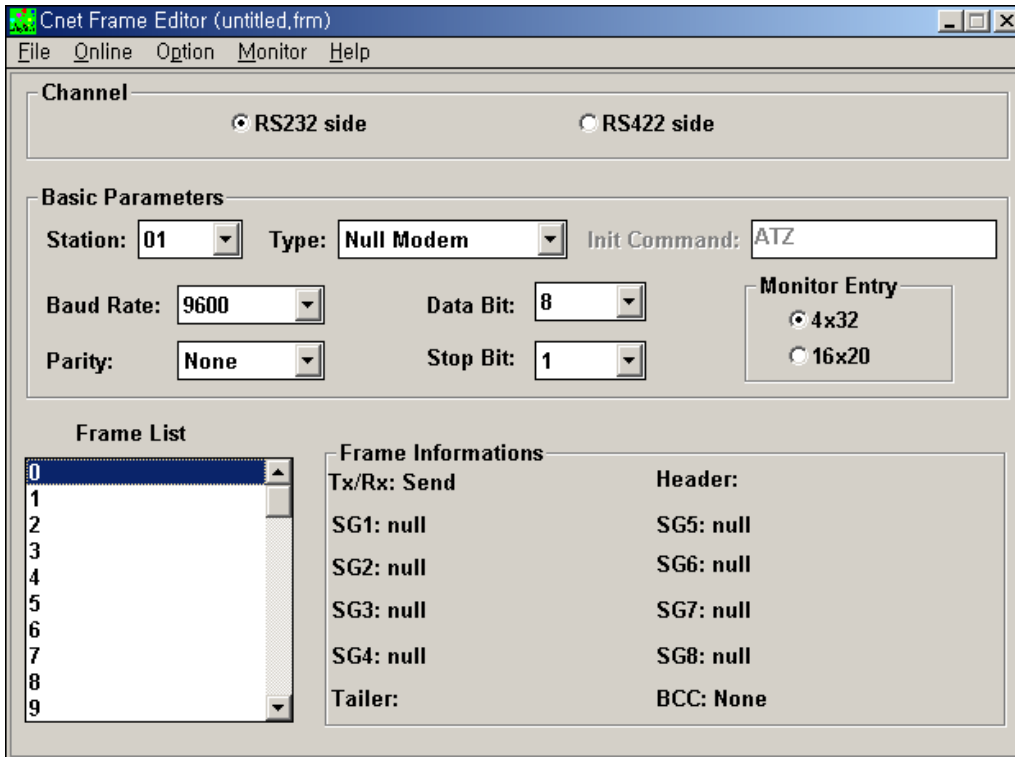

1) Basic parameter (Baudrate, Parity, Data bit, Stop bit) is required to correspond with the setting content of other station.

2) It is not necessary to write the frame list.

(b) Library -> Add item -> Library

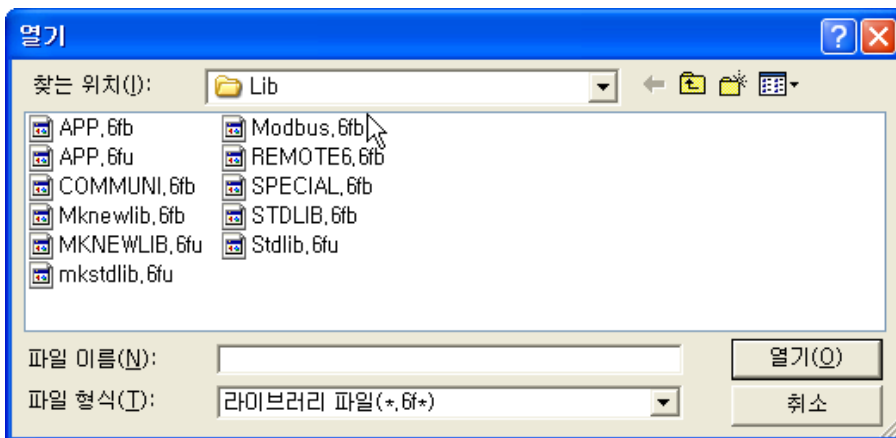

(c) Load the *Function Block* from Scan program of GMWIN program and program it.

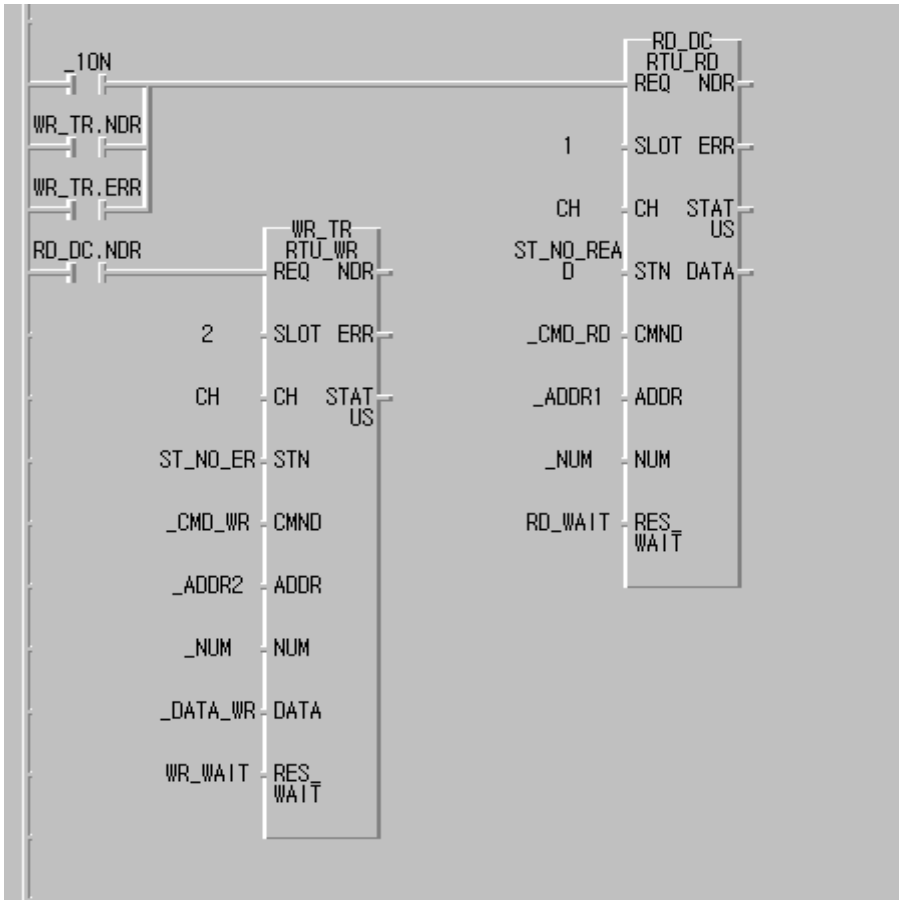

(2) When the Master is GM7

- (a) Slave station program: output the receiving data saved in M area to the output contact (Coil).
- (b) Master station program: After saving 16#FF (OR 255) to %MW0 (this corresponds with %MX0 ~ %MX15 or %MB0 ~ %MB1.) in the *Function Block* MOD0506 (function code 06), read %MX0 using the *Function Block* MOD0102 (function code 01) and save '0' to %MX0 ~ %MX9 using the *Function Block* MOD1516 (function code 15) again and then read %MW0 using the *Function Block* MOD0304 (function code 03).

1) Slave station setting and Program

Create new project file and new program for the Slave station.

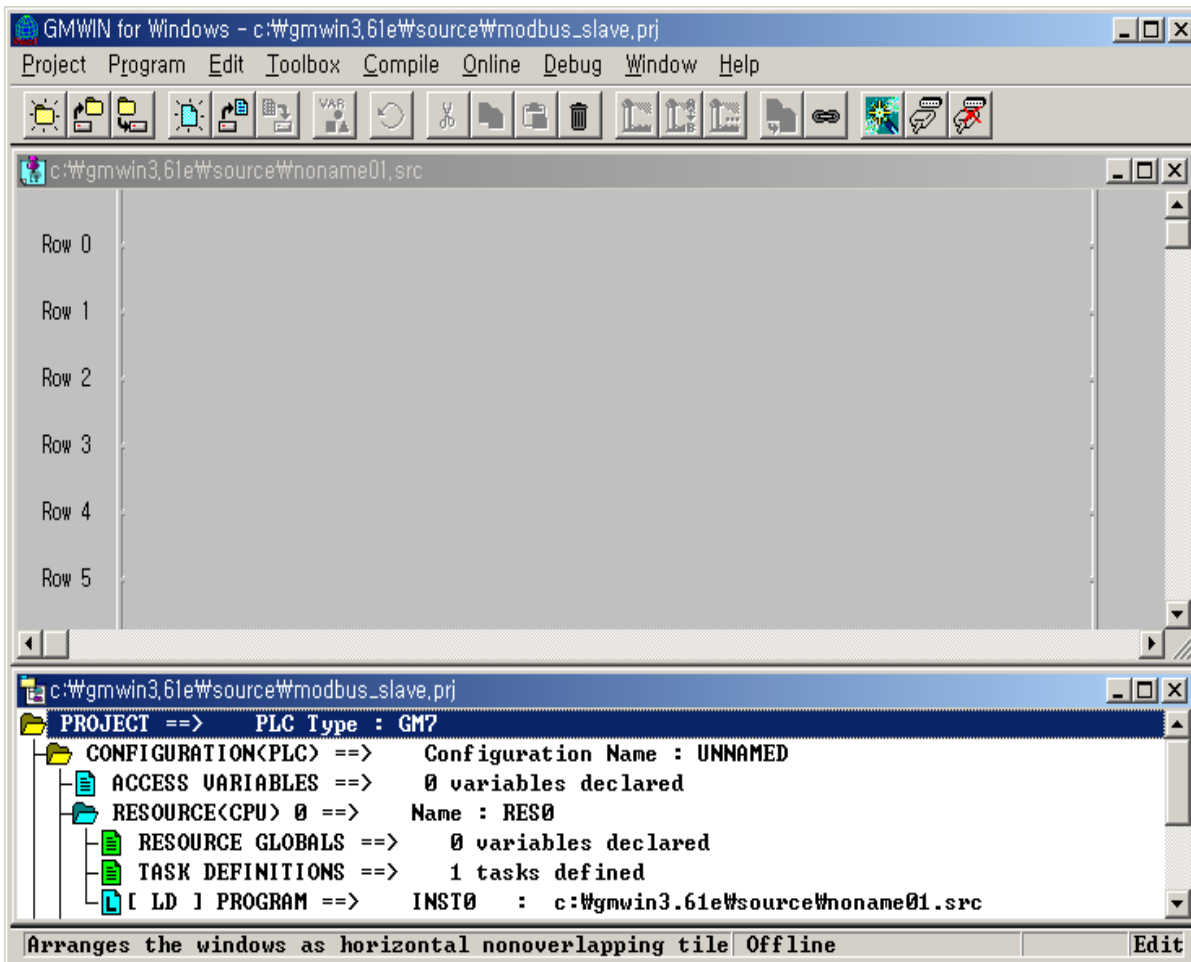

a) If you select 'Communication Parameter' from GMWIN parameter and double-click, the communication parameter menu window will open.

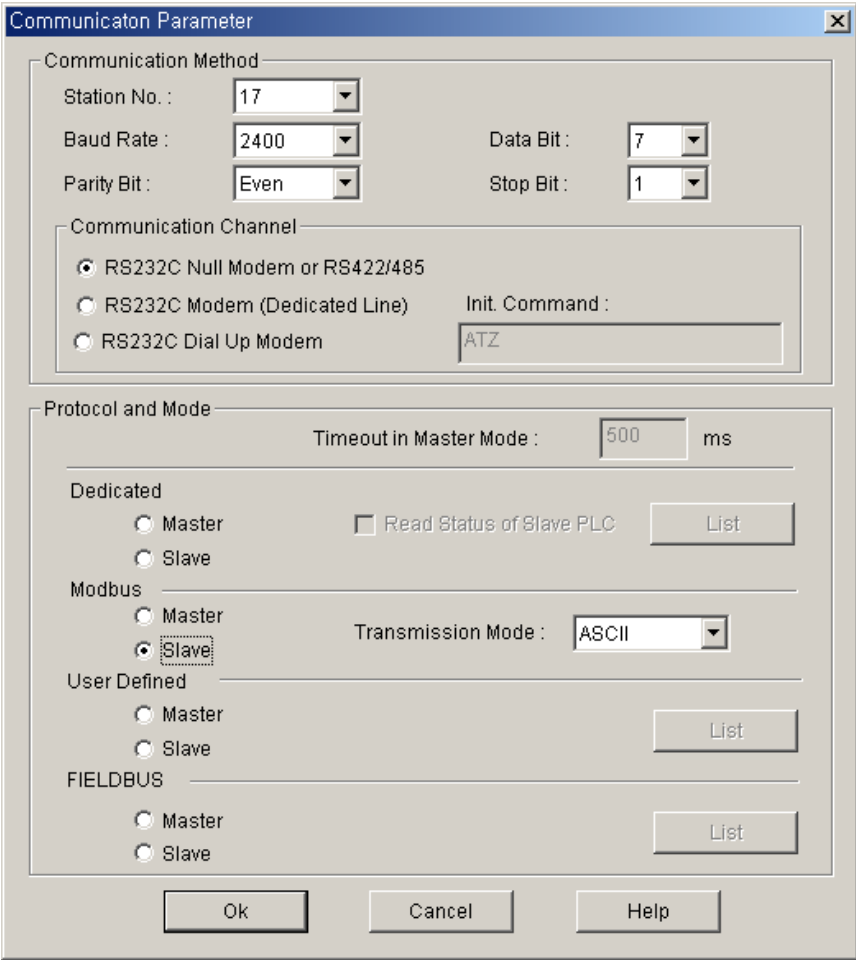

- Please set the parameter as below.

Communication method						Protocol and transmission mode	
Self station no.	Communication speed	Data bit	Parity bit	Maintenance bit	Communication channel	Modbus	Exclusive mode
17	2400	7	EVEN	1	RS232C null modem or RS422/485	Slave	ASCII

- b) After creating the program as below, download it in the GM7 basic unit of the Slave station. For further program creation and download method, please refer to GMWIN user's manual.
- ▶ The slave program is the program to output the data of M area to the output contact.

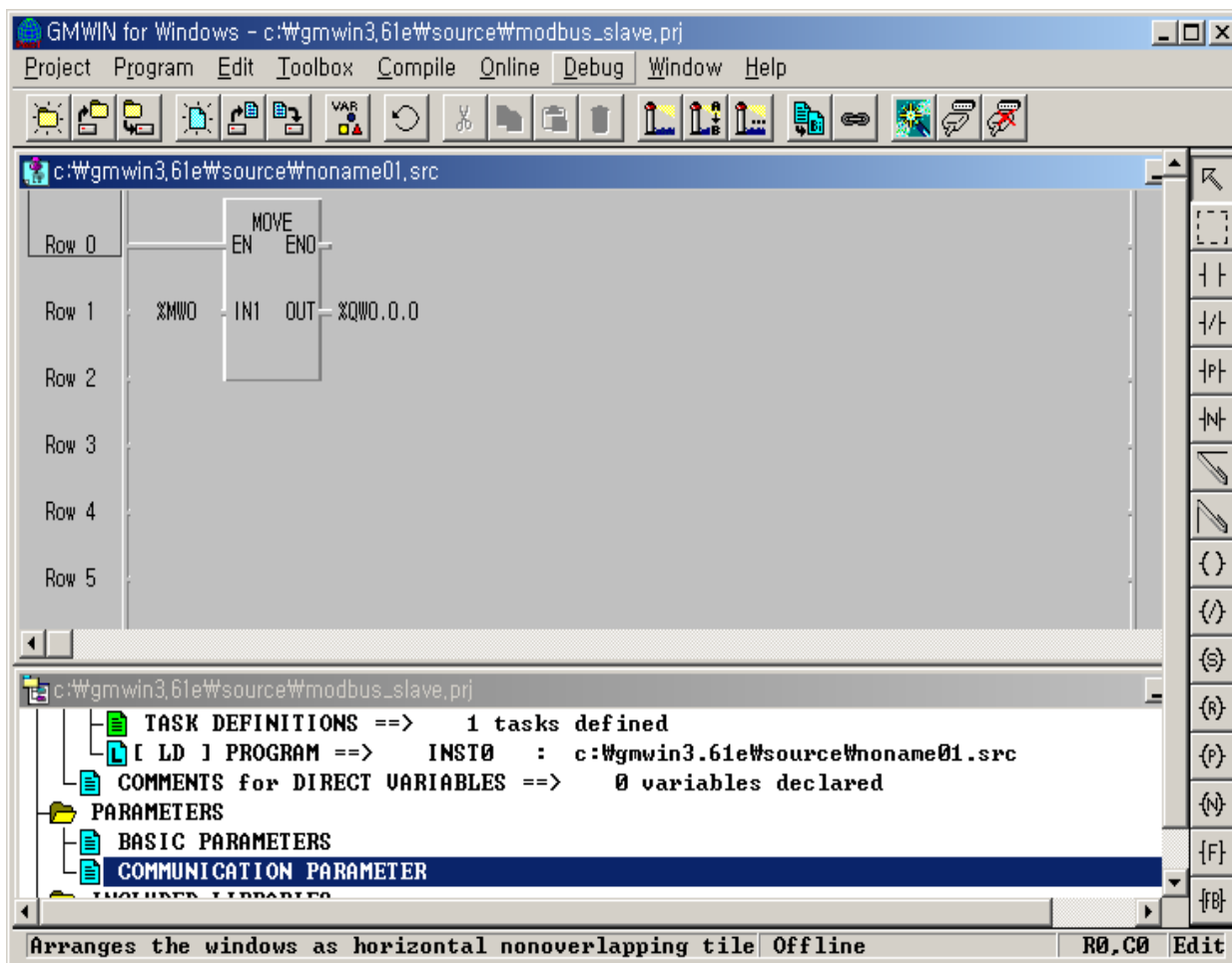

- 2) Master Station setting and Program
Create new project file and new program for the Master Station.

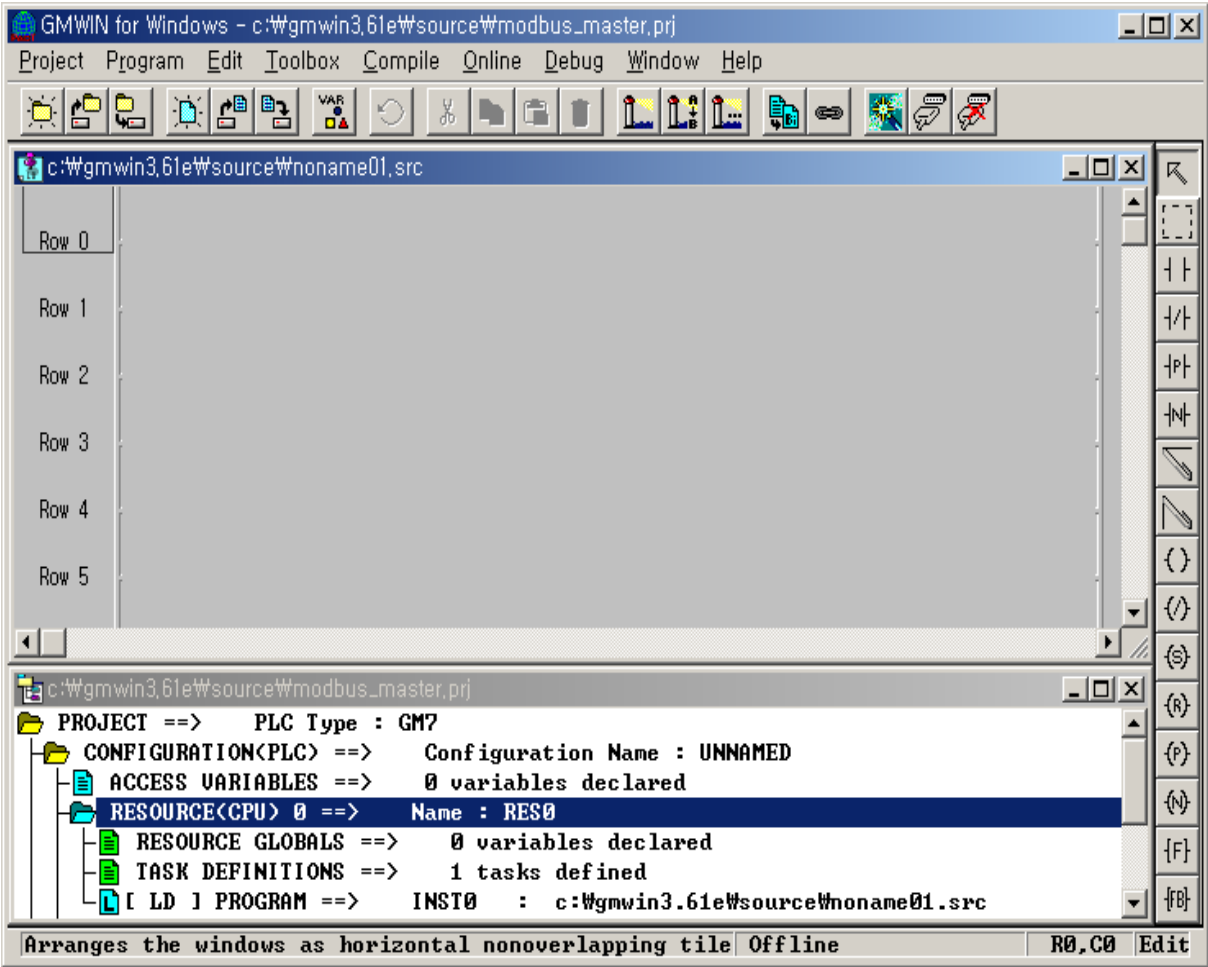

a) If you select 'Communication Parameter' from GMWIN parameter and double-click, the communication parameter menu window will be open.

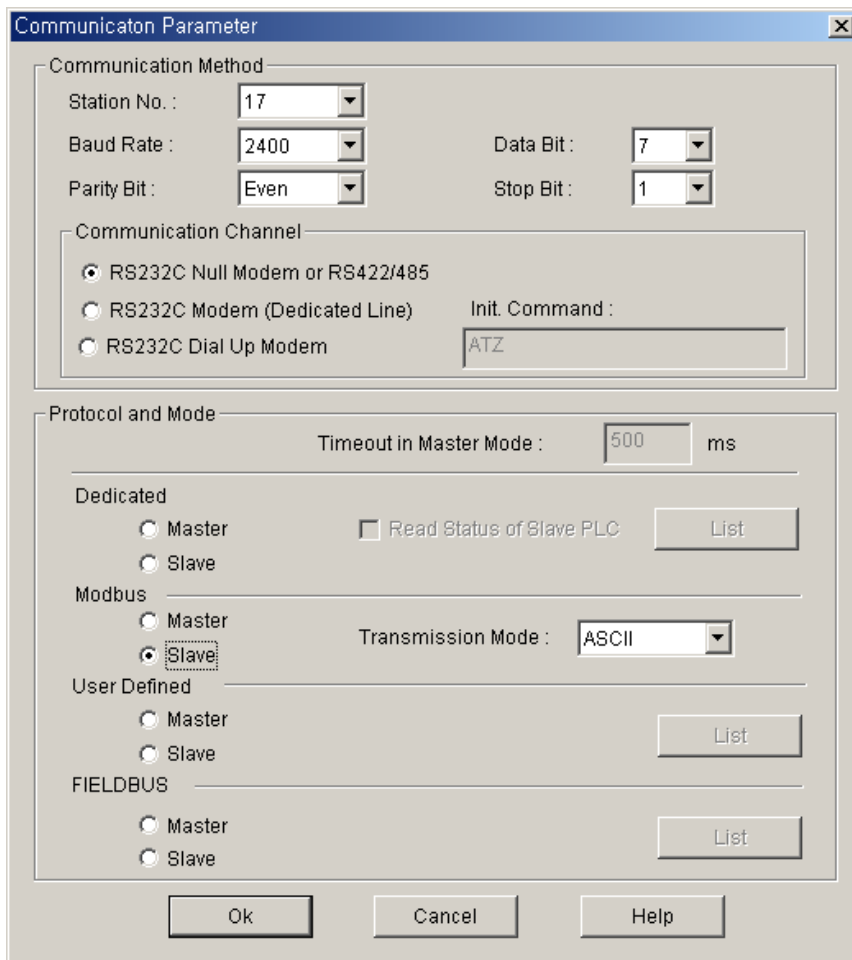

▶ Please set the parameter as below.

Communication method						Protocol & transmission mode	
Self station no.	Communication speed	Data bit	Parity bit	Maintenance bit	Communication channel	Modbus	Exclusive mode
1	2400	7	EVEN	1	RS232C null modem or RS422/485	Master	ASCII

- b) After creating the program as below, download it to the GM7 basic unit of the Master station. For further program creation and download method, please refer to GMWIN user's manual.
- ▶ In the program, the *Function Block* is used. If you double-click GMWIN 'inserted library files' items before using the *Function Block*, the library insert window will be open as below. Press 'Add (A)...' button and add COMM.7FB library and then press 'verify' button.

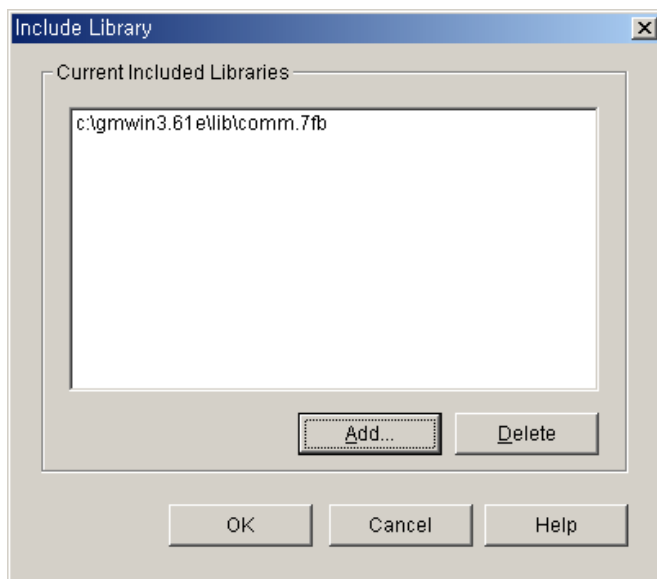
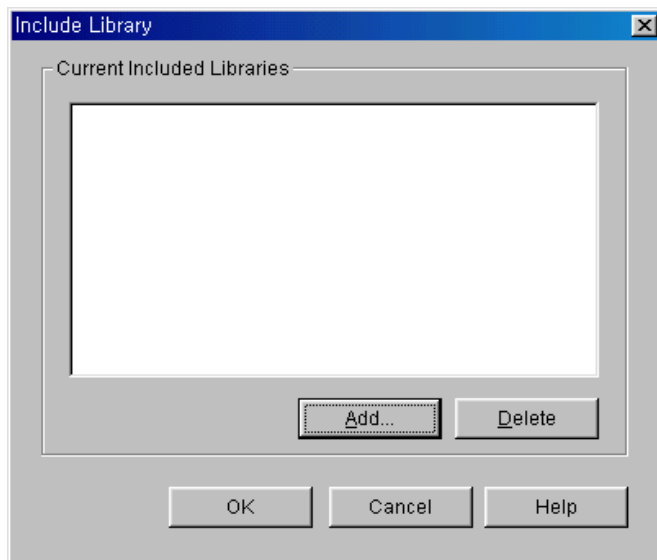

- Program Example

The screenshot displays the GMWIN software interface for Modbus communication programming. The main workspace is organized into rows (Row 0 to Row 23) and contains two primary logic blocks:

- WRITE MOD0506 (Rows 0-11):** This block is divided into 'REQ' and 'NDR' sections.
 - REQ Section (Rows 0-11):** Includes variables such as `_10N`, `WORD_RD.NDR`, `WRITE.NDR`, `WRITE.ERR`, `_SLV_ADDR`, `_FUNC0102`, `_AH0102`, `_AL0102`, `_NH0102`, `_NL0102`, and `_RD_DB`.
 - NDR Section (Rows 0-11):** Includes variables such as `BIT_RD MOD0102`, `SLV_ADDR`, `ERR_ADDR`, `FUNC STATUS`, `ADDR H`, `ADDR L`, `NUMH`, and `NUML`.
- MUL_WR MOD1516 (Rows 12-23):** This block is also divided into 'REQ' and 'NDR' sections.
 - REQ Section (Rows 12-23):** Includes variables such as `BIT_RD.NDR`, `BIT_RD.ERR`, `MUL_WR.NDR`, `MUL_WR.ERR`, `WORD_RD MOD0304`, `_SLV_ADDR`, `_FUNC0304`, `_AH0304`, `_AL0304`, `_NH0304`, `_NL0304`, and `_RD_DW`.
 - NDR Section (Rows 12-23):** Includes variables such as `MUL_WR`, `SLV_ADDR`, `ERR_ADDR`, `FUNC STATUS`, `ADDR H`, `ADDR L`, `NUMH`, `NUML`, `_BYTE_CNT`, and `WR_D ATA`.

The status bar at the bottom of the window indicates 'Sets the zooming level', 'Offline', 'R22.C2', and 'Edit'.

- ▶ After saving 16#FF (or 255) to %MW0 (this corresponds with %MX0 ~ %MX15 or %MB0 ~ %MB1.) in the *Function Block* MOD0506 (function code 06), read %MX0 using the *Function Block* MOD0102 (function code 01) and save '0' to %MX0 ~ %MX9 using the *Function Block* MOD1516 (function code 15) again and then read %MW0 using the *Function Block* MOD0304 (function code 03).
- ▶ You can see that 8 LED of output contact continues to repeat ON/OFF.
- ▶ The above figure is the screen that monitors the program execution. Thus, the value to be indicated on Array variable _RD_DB, _RD_DW is the result value after executing 'Read' not the initial value.
- ▶ The variable such as instance name.NDR, instance name.ERR, instance name.STATUS is generated automatically if declaring the instance variable of the *Function Block*.
- ▶ _1ON flag is the flag that will be ON only for 1Scan.
- ▶ Each *Function Block* input REQ is each *Function Block* output.
- ▶ The size of _BYTE_CNT must be same when converting the data by byte unit.
- ▶ If the size of Array variable is smaller than that of the data to read or write, error occurs.

- ▶ Variable table

Variable name	Variable type	Initial value	Variable name	Variable type	Initial value
_SLV_ADDR	USINT	17(H11)	_NH0102	USINT	0(H00)
_FUNC0102	USINT	1(H01)	_NH0304	USINT	0(H00)
_FUNC0304	USINT	3(H03)	_NH0506	USINT	0(H00)
_FUNC0506	USINT	6(H06)	_NH1516	USINT	0(H00)
_FUNC1516	USINT	15(H0F)	_NL0102	USINT	1(H01)
_AH0102	USINT	0(H00)	_NL0304	USINT	255(HFF)
_AH0304	USINT	0(H00)	_NL0506	USINT	1(H01)
_AH0506	USINT	0(H00)	_NL1516	USINT	10(H0A)
_AH1516	USINT	0(H00)	_RD_DB	BOOL type ARRAY[40]	{0,0,...,0}
_AL0102	USINT	0(H00)	_RD_DW	WORD type ARRAY[4]	{0,0,0,0}
_AL0304	USINT	0(H00)	_WR_DBW	BYTE type ARRAY[4]	{0,0,0,0}
_AL0506	USINT	0(H00)	_BYTE_CNT	USINT	2(H02)
_AL1516	USINT	0(H00)			

8.5.2 MASTER-K Series

(1) Program example 1) when using MODBUS

(a) This example is system configuration of RS-485 communication between GSL-DT4A and G7L-CUEC(K80S)

(b) program of GSL-DT4A output part

1) D0000 : set GSL-DT4A's station address (no.1) and fuction code (06 writing 1 word)

2) D0001 : set GSL-DT4A's address

3) D0002 : data storage area sended to the GSL-DT4A

4) When every 200msec rising edge, it send data saved at the M100 to Smart I/O and error history is saved at the M000

(c) program of GSL-DT4A output part

1) D0010 : set GSL-DT4A's station address (no.1) and fuction code (04 reading 1 word)

2) D0011 : set GSL-DT4A's address

3) D0012 : data no. to read from Smart I/O

(Because function code is 04, it reads 1 word)

4) Every 200msec when falling edge, it save data received from the input area of GSL-DT4A at the M110 and save it at the M001.

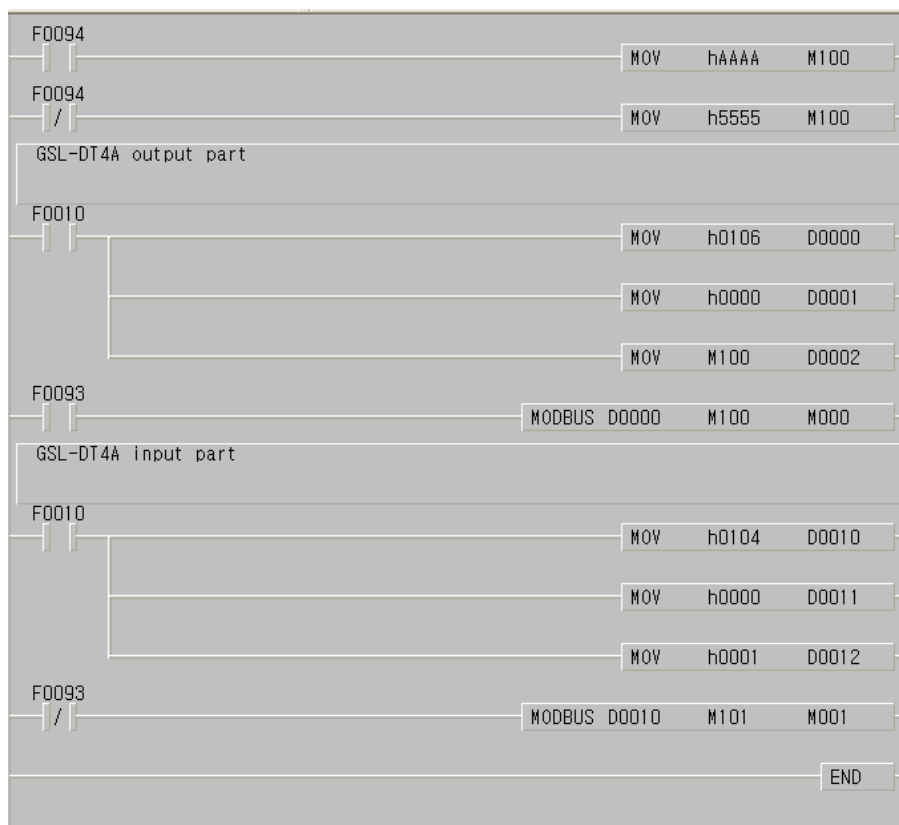

(2) program example 2) when using command MODCOM

(a) This example is system configuration of RS-485 communication between GSL-DT4A and G7L-CUEC(K120S)

(b) program of GSL-DT4A output part

- 1) D0000 : set GSL-DT4A's station address (no.1) and fuction code (06 writing 1 word)
- 2) D0001 : set GSL-DT4A's address
- 3) D0002 : data storage area sended to the GSL-DT4A

When every 1 sec rising edge, at the 1 channel, it send data saved at the M100 to Smart I/O and error history is saved at the M000

(C) program of GSL-DT4A output part

- 1) D0010 : set GSL-DT4A's station address (no.1) and fuction code (04 reading 1 word)
- 2) D0011 : set GSL-DT4A's address
- 3) D0012 : data no. to read from Smart I/O

(Because funcio code is 04, it reads 1 word)

4) When every 1sec falling edge, at the 1 channel, it save data received from the input area of GSL-DT4A at the M110 and save it at the M001.

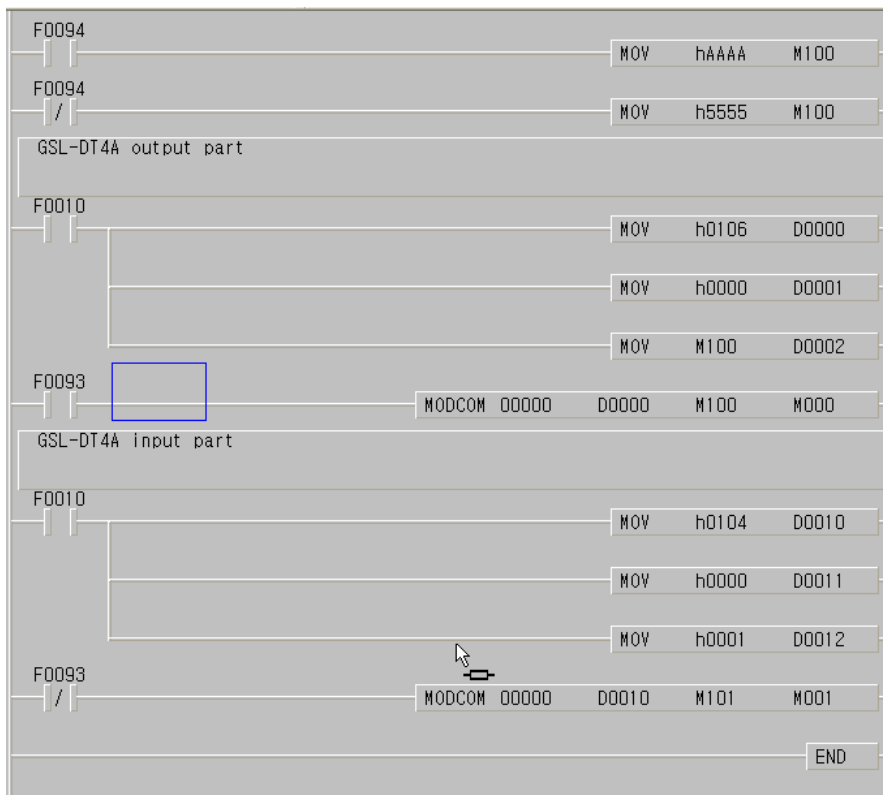

8.5.3 XGT Series

The following program read input 16 point of Smart I/O GSL-DT4A and save it at XGK M100, write M200's data at the Smart I/O's output (16 point) with setting XGT Cnet I/F module as client.

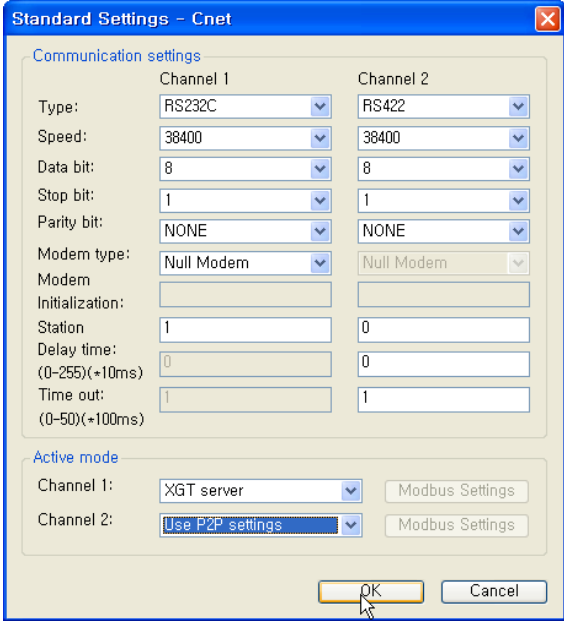
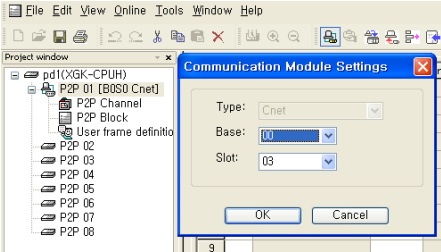
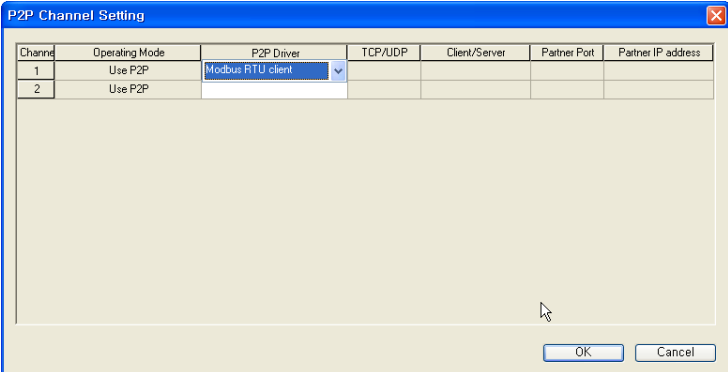
Sequence	Setting process	Setting method
1	Basic setting	
<ol style="list-style-type: none"> Setting channel 2. Setting run mode of channel as "use P2P". 		
2	P2P setting	
<ol style="list-style-type: none"> Double-click the P2P in the project window and select module location. 		
3	P2P Channel Setting	
<ol style="list-style-type: none"> Setting P2P driver as modbus RTU client. 		

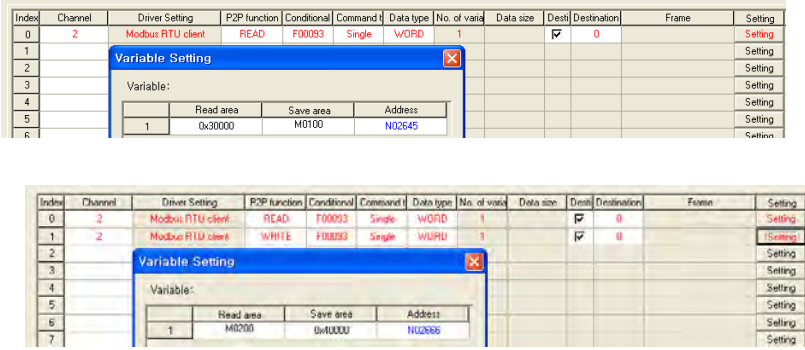
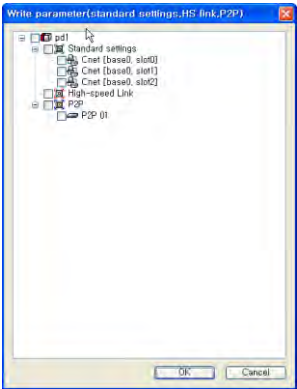
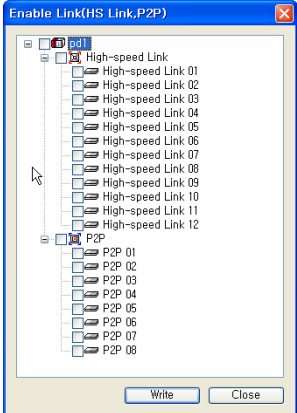
Sequence	Setting process	Setting method
4	P2P Block setting	
<ol style="list-style-type: none"> 1. In case of GSL-DT4A, it consists of input 16 point and output 16 point. Therefore set READ and WRITE in the same station. 2. In the above setting, input area which is word type in the READ part is set to be in the M100 of PLC. 3. Smart I/O output area is set to send data in the M200 of PLC. 		
5	Write Parameter	
6	Enable Link	

Chapter 9 Analog Module for Profibus-DP

9.1 Analog Input Module

9.1.1 Performance specification

Analog input module's performance specification is as follows.

Type Name	GPL-AV8C	GPL-AC8C
Channel No.	8 channels	
Analog Input Range	0 ~ 5V 1 ~ 5V 0 ~ 10 V -10 ~ +10 V	0 ~ 20mA 4 ~ 20mA -20 ~ 20mA
Digital Output Value	0~4000 (when 0 ~ 5V or 1 ~ 5V) 0~8000 (when 0 ~ 10 V) -8000~8000 (when -10 ~ +10 V)	0~8000 (when 0~20 mA or 4~20mA) -8000~8000 (when -20~20mA)
Input Impedance	1 MΩ	250Ω
Max. Tolerance Input	±15 V	±30mA
Resolution	1.25mV	2.5 μA
Precision	±0.3 % (Full Scale, Ta=0~55°C)	±0.3 % (Full Scale, Ta =23°C±5°C) ±0.4 % (Full Scale, Ta=0~55°C)
Transform Speed	Less than 10 ms /8 channel	
Response Period	Less than 10 ms /8 channel + transmission period (ms)	
Insulation Method	Analog input terminal ⇔ FG : insulation Analog input terminal ⇔ Communication terminal : insulation Analog input terminal ⇔ Channel : non-insulation	
External Supply Power	DC 24V (DC21.6 ~ 26.4V)	
External Consumption Current	DC24V : 220 mA	
Weight	313g	313g

Remark

1) You can't modify Offset/Gain Value which is regulated at the factory.

9.1.2 Name and role of each part

- Here it describes name and role of each part.

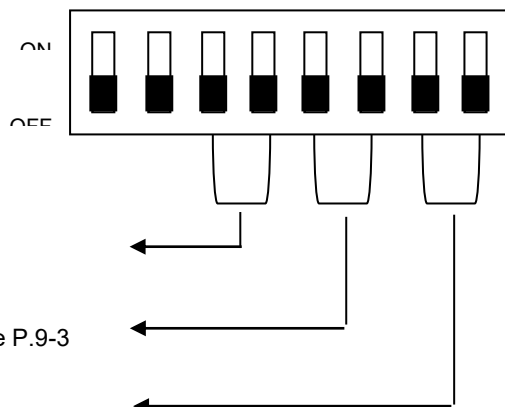
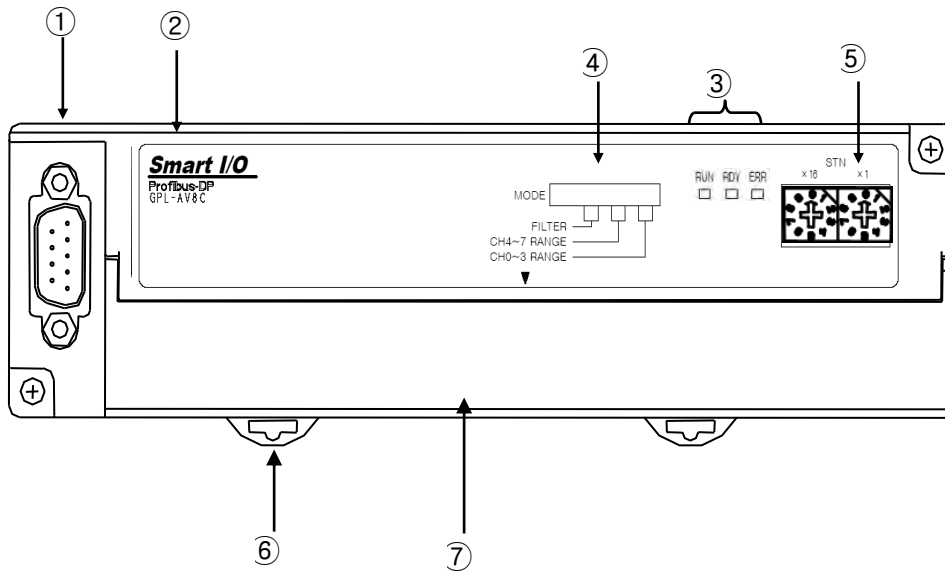

Filter designation: refer to the P.9-3

Designation of channel 4~7 input area: refer to the P.9-3

Designation of channel 0~3 input area: refer to the P.9-3

No.	Name	Use																																											
①	Connection Connector	Connect Master/remote module for communication. • 9 pin connector																																											
②	Smart I/O type name indication	• Indicates Pnet analog module's type name. GPL-AV8C: analog voltage input module GPL-AC8C: analog current input module																																											
③	Communication status indication LED	PWR LED Indicates status of power which is supplied at system. • On: when supplying is normal. • Off: when supplying is abnormal.																																											
		ERR LED Indicates transmitting and receiving status of communication module. • On: when communication status of communication module has error. • Off: when communication status of communication module is OK.																																											
		RDY LED Indicates status of communication module. (9.3.1 error type reference) • On: when analog module finishes initialization successfully. • Off: when analog module has error in initializing. • Flicker: when analog module ha error. <table border="1" style="margin-left: 20px;"> <thead> <tr> <th>Error type</th> <th>Flicker period</th> </tr> </thead> <tbody> <tr> <td>Severe trouble</td> <td>200ms</td> </tr> <tr> <td>Error in setting current input range</td> <td>0.5s</td> </tr> </tbody> </table> <p>* If you set mode selection switch On/On when using GPL-AC8C, It causes error. Regulate range again.</p>	Error type	Flicker period	Severe trouble	200ms	Error in setting current input range	0.5s																																					
Error type	Flicker period																																												
Severe trouble	200ms																																												
Error in setting current input range	0.5s																																												
④	Mode designation switch	Input range and filter setting. <table border="1" style="margin-left: 20px;"> <thead> <tr> <th>Setting</th> <th>Switch status</th> <th>Setting range (Voltage)</th> <th>Setting range (Current)</th> </tr> </thead> <tbody> <tr> <td rowspan="4">CH0 ~ 3</td> <td>Off</td> <td>Off</td> <td>-10V ~ +10V</td> </tr> <tr> <td>Off</td> <td>On</td> <td>0 ~ 10V</td> </tr> <tr> <td>On</td> <td>Off</td> <td>0 ~ 5V</td> </tr> <tr> <td>On</td> <td>On</td> <td>1V ~ 5V</td> </tr> <tr> <td rowspan="4">CH4 ~ 7</td> <td>Off</td> <td>Off</td> <td>-10V ~ +10V</td> </tr> <tr> <td>Off</td> <td>On</td> <td>0 ~ 10V</td> </tr> <tr> <td>On</td> <td>Off</td> <td>0 ~ 5V</td> </tr> <tr> <td>On</td> <td>On</td> <td>1V ~ 5V</td> </tr> <tr> <td rowspan="4">Filter</td> <td>Off</td> <td>Off</td> <td>Disabling filter</td> </tr> <tr> <td>Off</td> <td>On</td> <td>Filter parameter 33</td> </tr> <tr> <td>On</td> <td>Off</td> <td>Filter parameter 66</td> </tr> <tr> <td>On</td> <td>On</td> <td>Filter parameter 99</td> </tr> </tbody> </table>	Setting	Switch status	Setting range (Voltage)	Setting range (Current)	CH0 ~ 3	Off	Off	-10V ~ +10V	Off	On	0 ~ 10V	On	Off	0 ~ 5V	On	On	1V ~ 5V	CH4 ~ 7	Off	Off	-10V ~ +10V	Off	On	0 ~ 10V	On	Off	0 ~ 5V	On	On	1V ~ 5V	Filter	Off	Off	Disabling filter	Off	On	Filter parameter 33	On	Off	Filter parameter 66	On	On	Filter parameter 99
Setting	Switch status	Setting range (Voltage)	Setting range (Current)																																										
CH0 ~ 3	Off	Off	-10V ~ +10V																																										
	Off	On	0 ~ 10V																																										
	On	Off	0 ~ 5V																																										
	On	On	1V ~ 5V																																										
CH4 ~ 7	Off	Off	-10V ~ +10V																																										
	Off	On	0 ~ 10V																																										
	On	Off	0 ~ 5V																																										
	On	On	1V ~ 5V																																										
Filter	Off	Off	Disabling filter																																										
	Off	On	Filter parameter 33																																										
	On	Off	Filter parameter 66																																										
	On	On	Filter parameter 99																																										
⑤	Self station setting switch	Switch for setting own station No. Available to set to 126 stations. (0 station reservation) • X16: 10 digit indication • X1: 1 digit indication																																											
⑥	HOOK for DIN rail	• HOOK for DIN rail																																											
⑦	Terminal block	• Terminal block array for wiring of I/O * refer to the Ch. 9.1.6																																											

9.1.3 Characteristic of input transformation

(1) GPL-AV8C

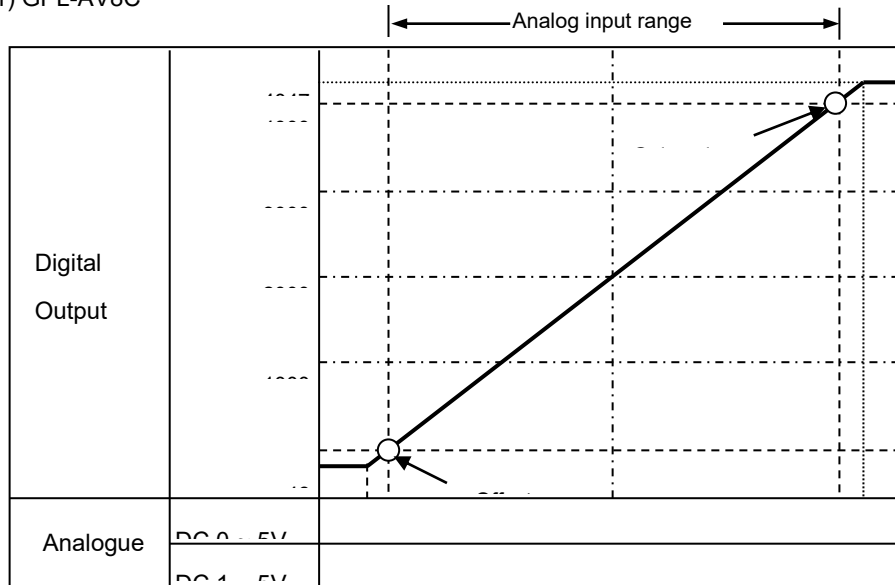

[Figure 9.1] I/O transformation characteristic (input range: 0~5V, 1~5V)

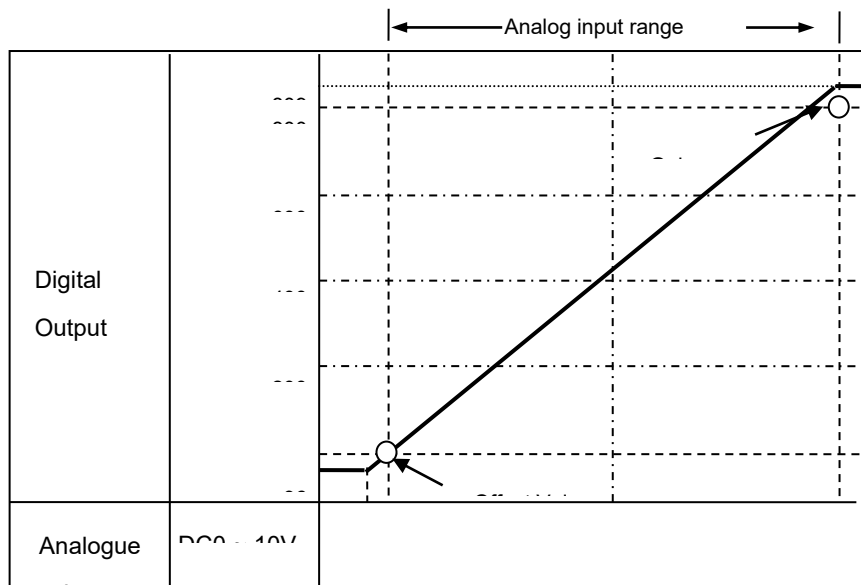

[Figure 9.2] I/O transformation characteristic (input range: 0~10V)

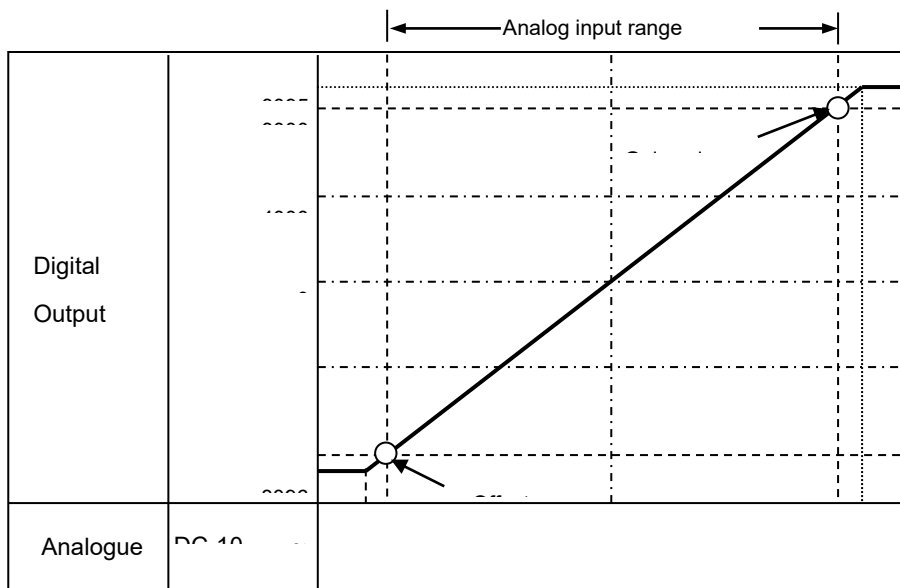

[Figure 9.3] I/O transformation characteristic (input range: -10~10V)

(2) GPL-AC8C

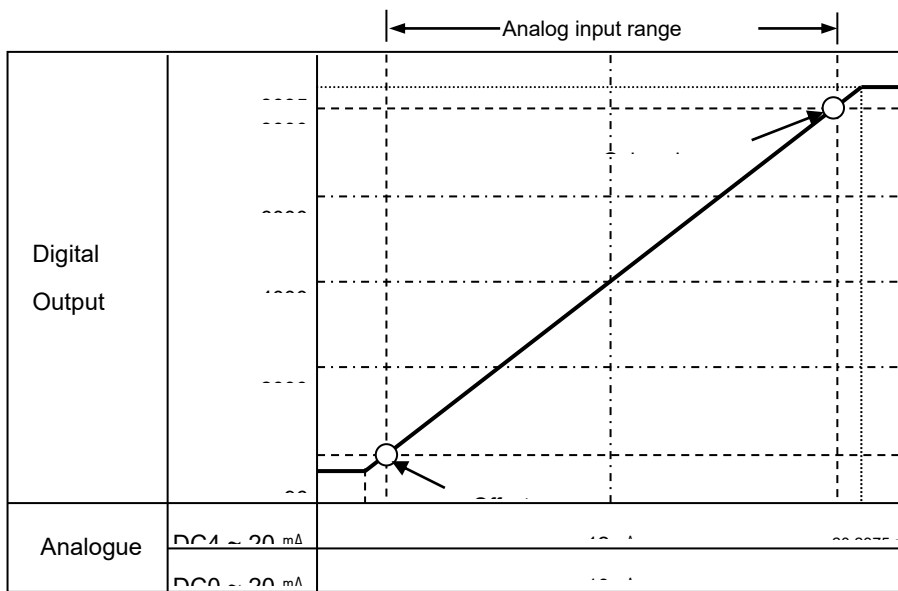

[Figure 9.4] I/O transformation characteristic (input range: 4~20 mA, 0~20 mA)

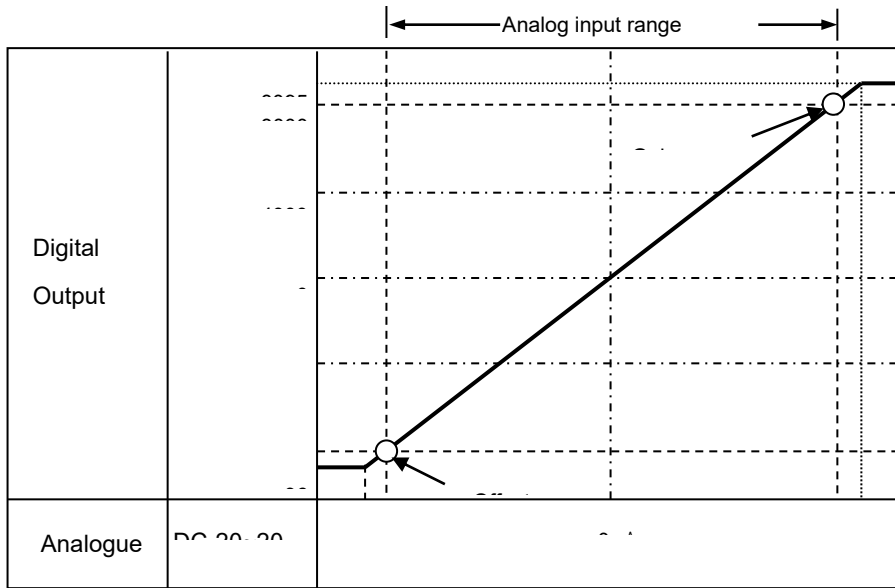

[Figure 9.5] I/O transformation characteristic (input range: -20~20 mA)

9.1.4 Filter Function

We can get stable digital output value by using Filter Function which filters noise and rapid change of input value. It is available to designate filter parameter per channel by user program and I/O parameter setting.

•setting range: 33 / 66 / 99 (%)

$$F[n] = (1 - \alpha) \times A[n] + \alpha \times F[n - 1]$$

- F[n]: present filter output value
- A[n]: present A/D transformation value
- F[n-1]: previous filter output value
- α: filter parameter
(0.33, 0.66, 0.99: previous value's weight)

- *1 We can set filter parameter by using mode switch which is located at the upper main body. Setting parameter is the same with right table.
- *2 The following is a figure which indicates change of each digital value corresponding to filter parameter after setting 0~10V input range.

Filter	CH0~3		CH4~7	
Filter	Off	Off	Off	Off
0.33	Off	On	Off	On
0.66	On	Off	On	Off
0.99	On	On	On	On

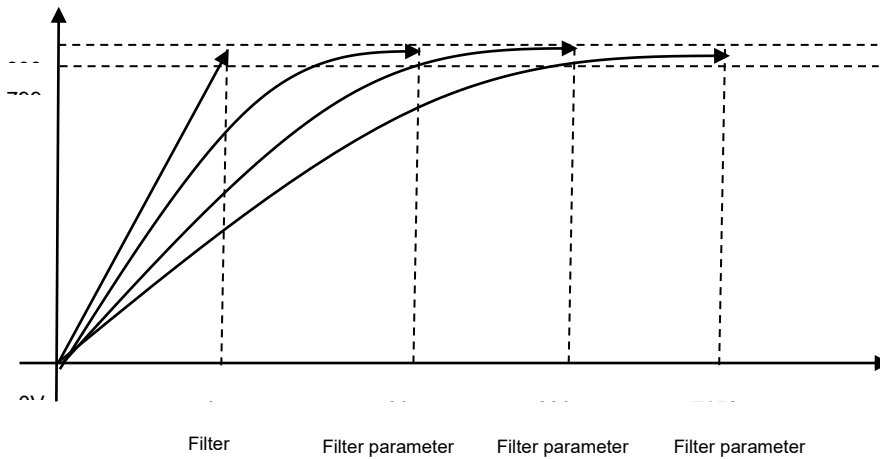

Remark

- 1) Before changing mode switch, you should turn off the power.
- 2) Filter setting switch is located in the upper body of module as the following figure

Filter setting switch

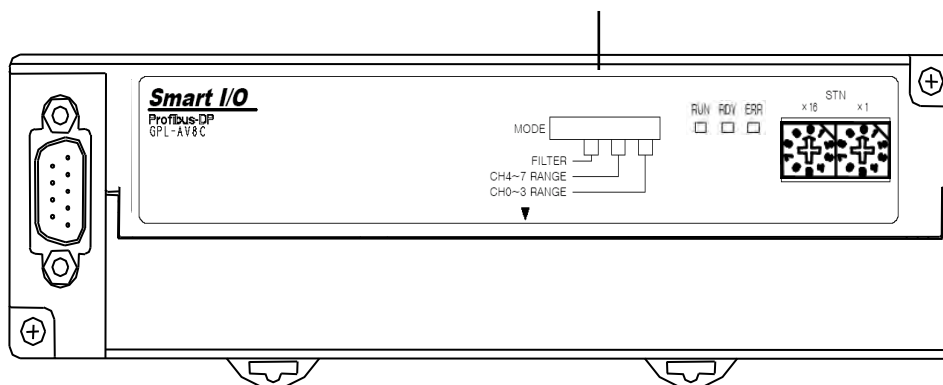

9.1.5 Installing and wiring

(1) Terminal block

1) GPL-AV8C

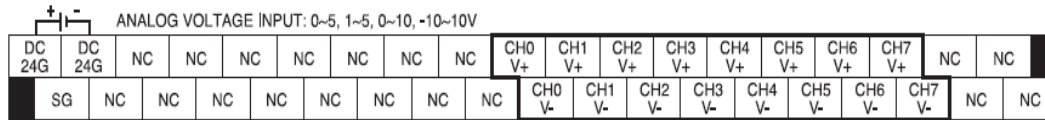

2) GPL-AC8C

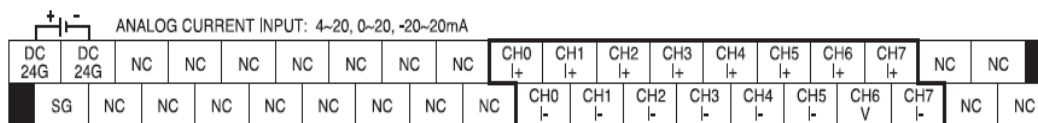

(2) Notice in wiring

- 1) Do not put AC power line near external signal line of analog input module.
You should maintain enough distance so that you can escape effect of induction noise from AC power.
- 2) When choosing the wire, you consider temperature and current. We recommend bigger than AWE22(0.3mm²) size wire. (including AWE22(0.3mm²) size wire)
- 3) If you expose wire to high temperature, it may cause error or damage because of short or ground.
- 4) When wiring terminal block, check polarity.
- 5) If you install wire near a high voltage line, it may cause error or damage because of induction obstacle.

(3) Wiring example

1) GPL-AV8C

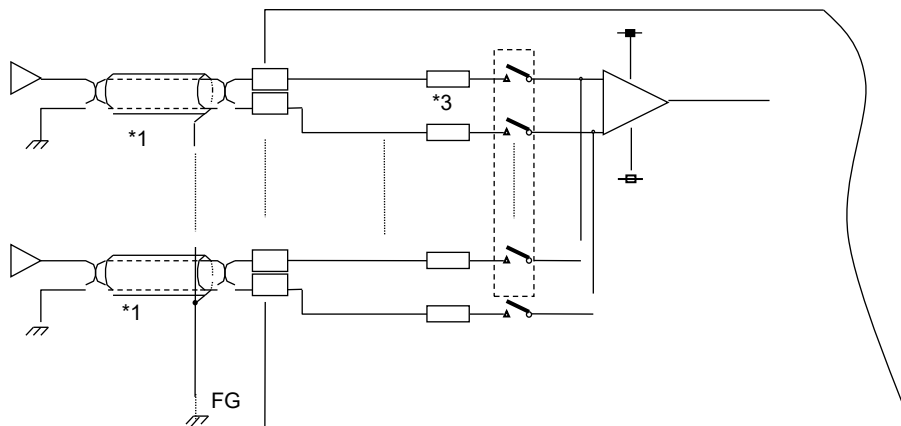

2) GPL-AC8C

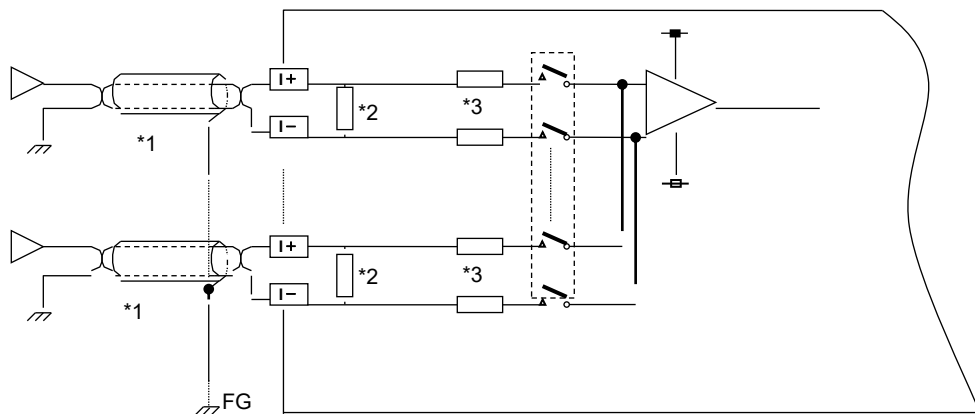

(4) 2-Wire Transmitter wiring example (current input)

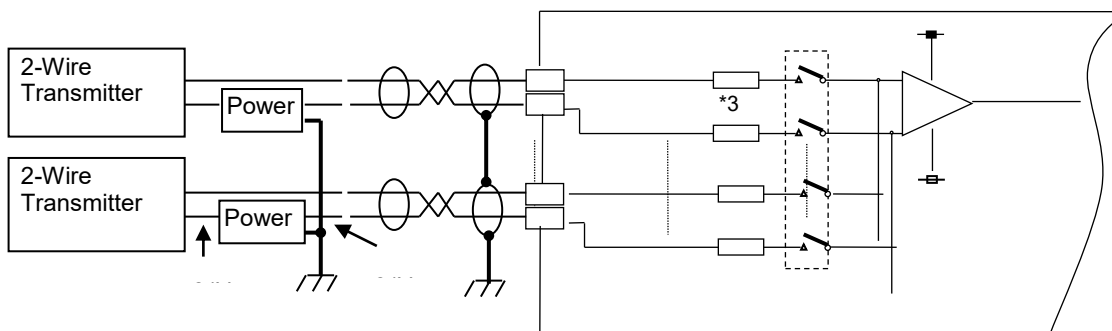

(5) 4-Wire Transmitter wiring example (voltage/current input)

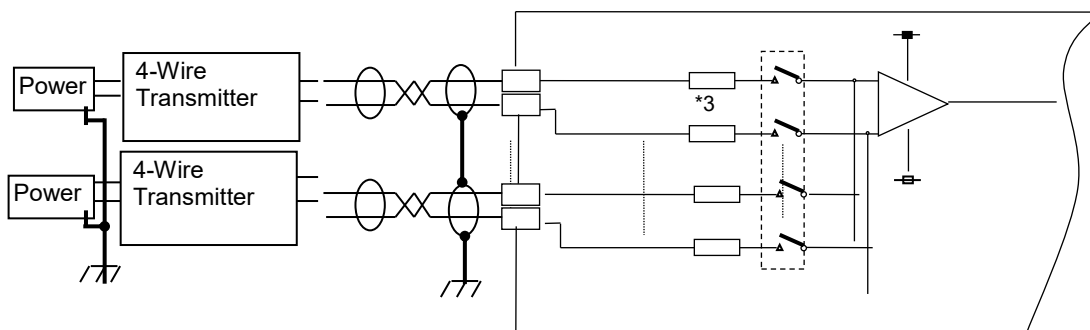

- *1) Use 2 core wire twisted-shield.
-Recommended wire size is AWG 22. (including AWE22(0.3mm²) size wire)
- *2) GPL-AC8C's input resistor is 250 Ω (typ.).
- *3) GPL-AV8C's input resistor is 1MΩ (min.).

9.1.6 Program example

(1) When using GLOFA Pnet master module

1) SyCon setting method

- Refer to the Chapter 5.3.3 for use of SyCon.

2) GMWIN setting method

A) High Speed Link setting method

- Open GMWIN's High Speed Link window.

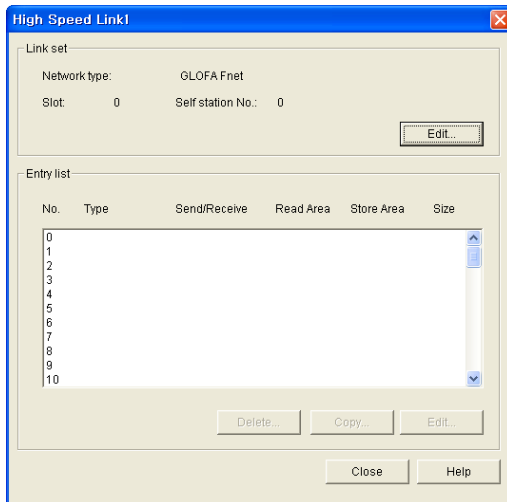

- Press [Edit] and designate slot location where Pnet master is equipped after choosing GLOFA Pnet.

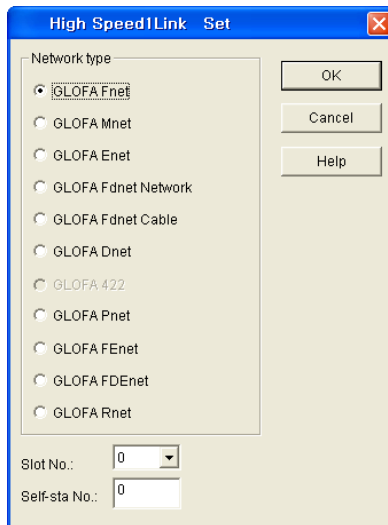

- Assign memory area to store analog input transformation value by double-clicking the registration list as follows.

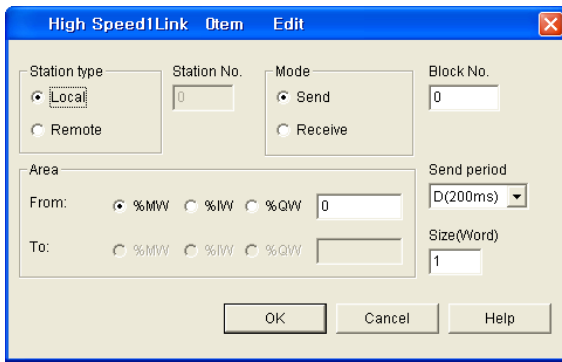

- Analog input module use 2 byte per channel and one analog input module consist of 8 channel and 16 byte.

B) Reading analog transformation value in GMWIN

- Because analog input transformation value is signed 10 digit number, to read normal data in GMWIN, read signed value or assign M region's address after declaring variable by using WORD_TO_INT function.

(_HS1LTRBL ahead of transformation function is High Speed Link Flag used not to execute function when error of High Speed Link occurs)

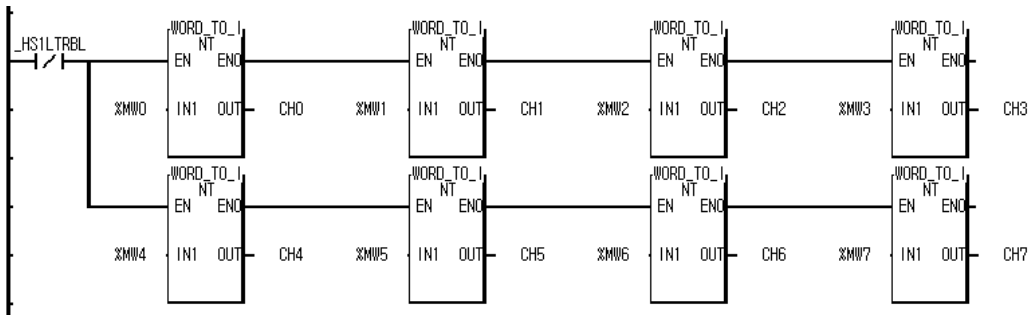

< Example of WORD_TO_INT function use >

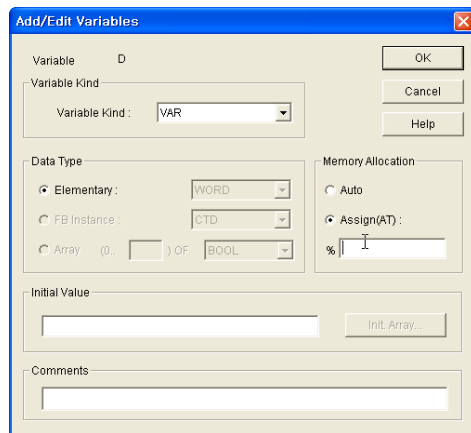

<Example of variable use>

(2) When using MASTER-K Pnet

1) SyCon setting method

- Refer to the Chapter 5.3.3 to set SyCon.

2) KGLWIN setting method

A) High Speed Link setting method

- Open KGLWIN's parameter window.

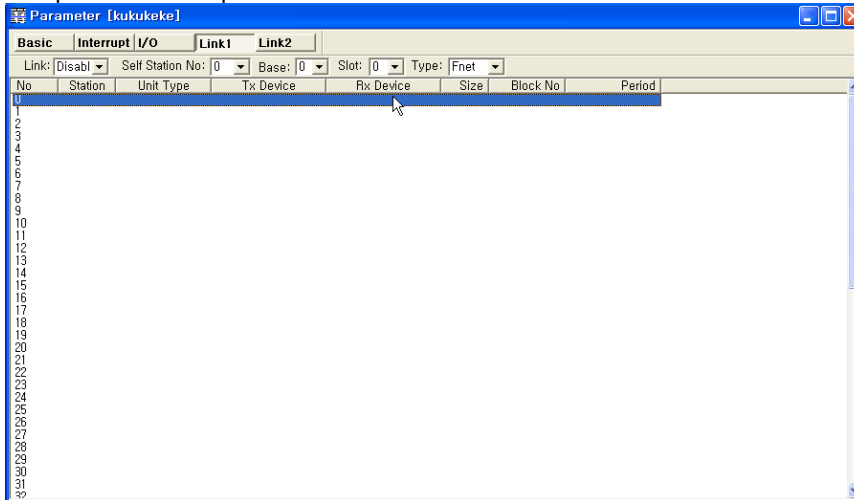

- Open setting window by double-clicking the category.

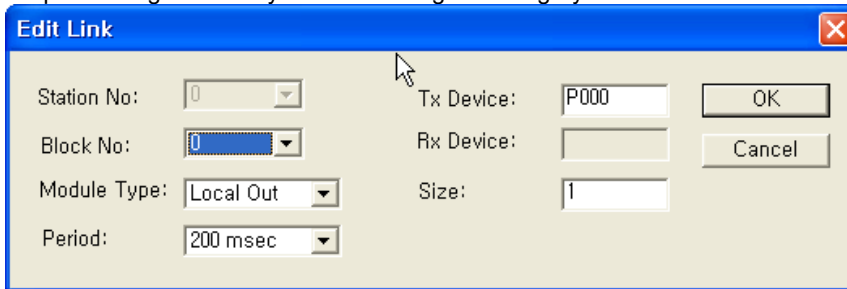

- As the above, read analog input transformation value and set memory region.

- Analog input module use 2 byte per channel and analog input transformation value is 8 channels per module and 16 byte.

B) Reading analog input transformation value in KGLWIN

- The following program is a simple example which analog input transformation value received from M0 to D region.

(BLD instruction is used as a point not to execute A/D transformation when High Speed Link No.1 has trouble.)



9.2 Analog Output Module

9.2.1 Performance specification

Analog output module's performance specification is as follows

Type Name	GPL-DV4C	GPL-DC4C
Channel no.	4 channels	
Analog output range	0 ~ 5V 1~ 5V 0 ~ 10 V -10 ~ +10 V	0 ~ 20mA 4 ~ 20mA
Digital input value	0 ~ 4000 (when 0 ~ 5V or 1~ 5V) 0 ~ 8000(when 0 ~ 10V) -8000 ~ 8000 (when -10 ~ +10V)	0 ~ 8000
Load impedance	Upper 1 kΩ (1~5V / 0~5V) Upper 2 kΩ (0~10V /-10~10V)	Less than 500Ω
Resolution	1.25mV	2.5 μA
Precision	±0.3 % (Full scale, Ta=0 ~ 55°C)	±0.3 % (Full scale, Ta=23°C±5°C) ±0.4 % (Full scale, Ta=0 ~ 55°C)
Transformation speed	Less than 10 ms / 4 channels	
Response period	Less than 10 ms/ 8 channel + transmission period (ms)	
Insulation method	Analog input terminal ⇔ FG : insulation Analog input terminal ⇔ communication terminal : insulation Analog input terminal ⇔ channel : non-insulation	
External supply power	DC 24V (DC20.4 ~ 28.8V)	
External consumption current	210 mA	240 mA
Weight	314g	322g

Remark

1) You can't modify Offset/ gain value which is regulated at the factory

9.2.2 Name and role of each part

- Describes the name and role of each part.

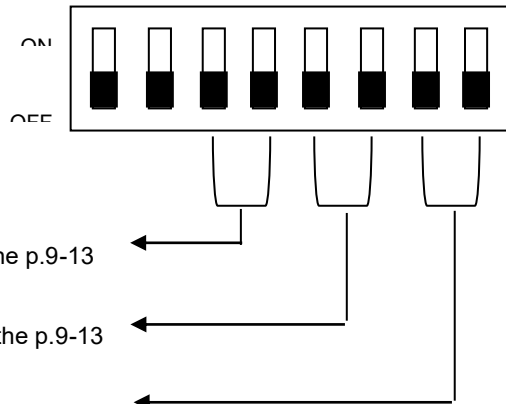
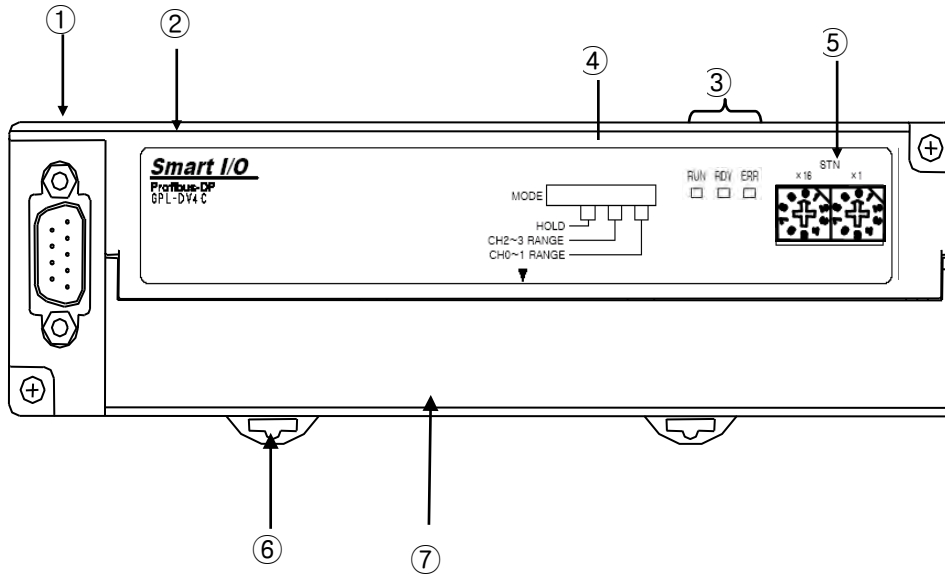

HOLD (Output designation when error occurs): refer to the p.9-13

Designation of output Ch.2~3 area: refer to the p.9-13

Designation of output Ch.0~1 area: refer to the p.9-13

No.	Model name	Use																																																								
①	Connection connector	Connects Master/remote module for communication • 9 pin connector																																																								
②	Smart I/O model name indication	• Indicates model name of Pnet analog module GPL-DV4C: analog voltage output module GPL-DC4C: analog current output module																																																								
③	Communication status indication LED	PWR LED Indicates status of power supplier which is supplied at system. • On: when supplying is normal. • Off: when supplying is abnormal.																																																								
		ERR LED Indicates transmitting and receiving status of communication module. • On: when communication status of communication module has error. • Off: when communication status of communication module is OK																																																								
		RDY LED Indicates communication module status (refer to the Ch. 9.3.1) • On: when analog module finishes initialization successfully. • Off: when analog module has error in initializing. • Flicker: when detecting error in analog module <table border="1" style="margin-left: 20px;"> <thead> <tr> <th>Error type</th> <th>Flicker period</th> </tr> </thead> <tbody> <tr> <td>Severe trouble</td> <td>200ms</td> </tr> <tr> <td>Excess of digital input value range</td> <td>1s</td> </tr> </tbody> </table>	Error type	Flicker period	Severe trouble	200ms	Excess of digital input value range	1s																																																		
Error type	Flicker period																																																									
Severe trouble	200ms																																																									
Excess of digital input value range	1s																																																									
④	Mode designation switch	<p>Input range and output setting when error</p> <table border="1" style="margin-left: 20px;"> <thead> <tr> <th>setting</th> <th colspan="2">Switch status</th> <th>Setting range(voltage)</th> <th>Setting range(current)</th> </tr> </thead> <tbody> <tr> <td rowspan="4">CH0 ~ 1</td> <td>Off</td> <td>Off</td> <td>-10V ~ +10V</td> <td>0 ~ 20mA</td> </tr> <tr> <td>Off</td> <td>On</td> <td>0 ~ 10V</td> <td>4mA ~ 20mA</td> </tr> <tr> <td>On</td> <td>Off</td> <td>0 ~ 5V</td> <td>-</td> </tr> <tr> <td>On</td> <td>On</td> <td>1V ~ 5V</td> <td>-</td> </tr> <tr> <td rowspan="4">CH2 ~ 3</td> <td>Off</td> <td>Off</td> <td>-10V ~ +10V</td> <td>0 ~ 20mA</td> </tr> <tr> <td>Off</td> <td>On</td> <td>0 ~ 10V</td> <td>4mA ~ 20mA</td> </tr> <tr> <td>On</td> <td>Off</td> <td>0 ~ 5V</td> <td>-</td> </tr> <tr> <td>On</td> <td>On</td> <td>1V ~ 5V</td> <td>-</td> </tr> <tr> <td rowspan="4">HOLD</td> <td>Off</td> <td>Off</td> <td colspan="2">Puts out 0 when error</td> </tr> <tr> <td>Off</td> <td>On</td> <td colspan="2">Puts out Max. value when error</td> </tr> <tr> <td>On</td> <td>Off</td> <td colspan="2">Puts out Min. value when error</td> </tr> <tr> <td>On</td> <td>On</td> <td colspan="2">Puts out previous value when error</td> </tr> </tbody> </table>	setting	Switch status		Setting range(voltage)	Setting range(current)	CH0 ~ 1	Off	Off	-10V ~ +10V	0 ~ 20mA	Off	On	0 ~ 10V	4mA ~ 20mA	On	Off	0 ~ 5V	-	On	On	1V ~ 5V	-	CH2 ~ 3	Off	Off	-10V ~ +10V	0 ~ 20mA	Off	On	0 ~ 10V	4mA ~ 20mA	On	Off	0 ~ 5V	-	On	On	1V ~ 5V	-	HOLD	Off	Off	Puts out 0 when error		Off	On	Puts out Max. value when error		On	Off	Puts out Min. value when error		On	On	Puts out previous value when error	
setting	Switch status		Setting range(voltage)	Setting range(current)																																																						
CH0 ~ 1	Off	Off	-10V ~ +10V	0 ~ 20mA																																																						
	Off	On	0 ~ 10V	4mA ~ 20mA																																																						
	On	Off	0 ~ 5V	-																																																						
	On	On	1V ~ 5V	-																																																						
CH2 ~ 3	Off	Off	-10V ~ +10V	0 ~ 20mA																																																						
	Off	On	0 ~ 10V	4mA ~ 20mA																																																						
	On	Off	0 ~ 5V	-																																																						
	On	On	1V ~ 5V	-																																																						
HOLD	Off	Off	Puts out 0 when error																																																							
	Off	On	Puts out Max. value when error																																																							
	On	Off	Puts out Min. value when error																																																							
	On	On	Puts out previous value when error																																																							
⑤	Self station No. setting switch	Switch for setting own node station No. Available to set to 126 station(0 station reservation) • X16: 10digit indication • X1: 1digit indication																																																								
⑥	HOOK for DIN rail	• HOOK for DIN rail																																																								
⑦	Terminal block	• Terminal block array for I/O wiring * refer to the Ch.9.2.6																																																								

9.2.3 I/O transformation characteristic

1) GPL-DV4C

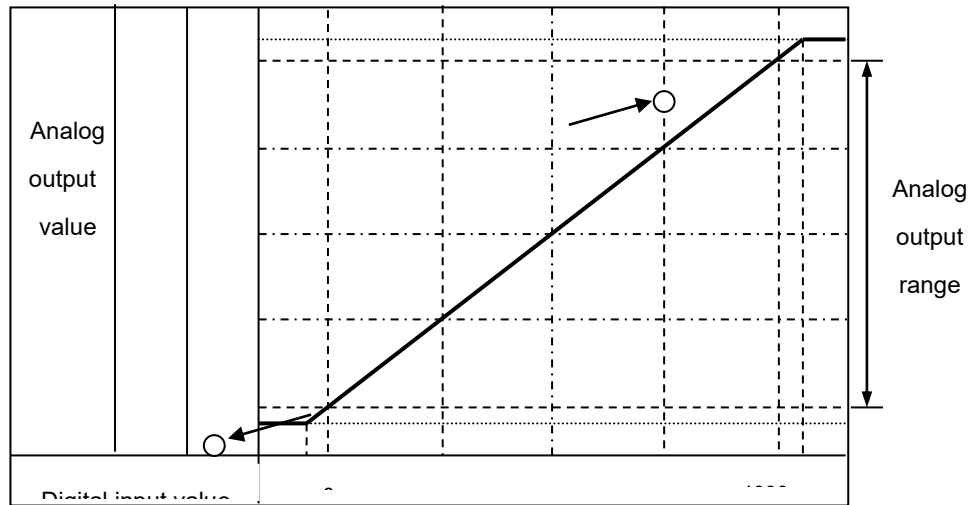

[Figure 9.6] I/O transformation characteristic (output range: 0~5V, 1~5V)

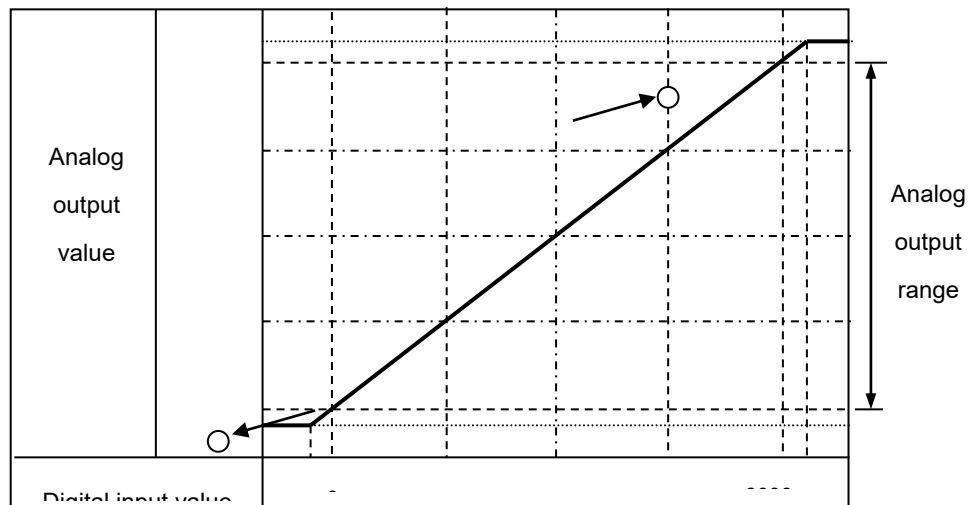

[Figure 9.7] I/O transformation characteristic (Output range: 0~10V)

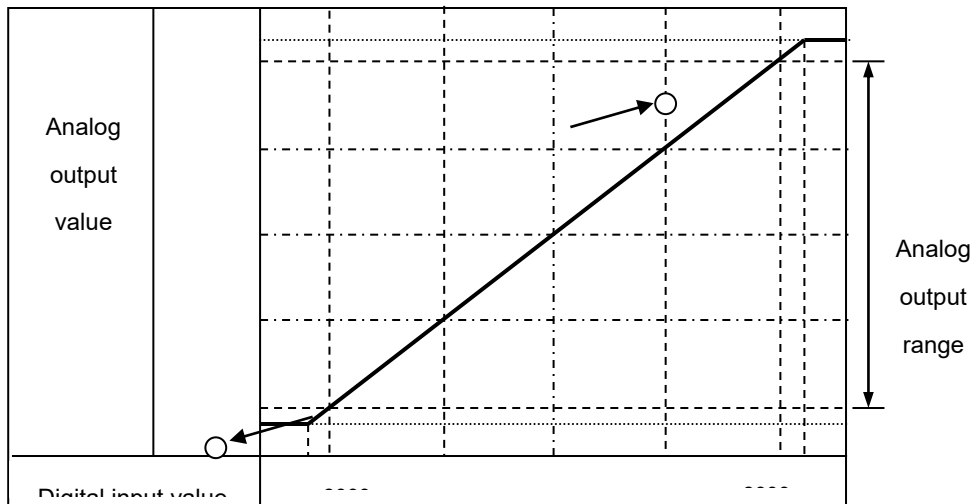

[Figure 9.8] I/O transformation characteristic (Output range: -10V~10V)

2) GPL-DC4C

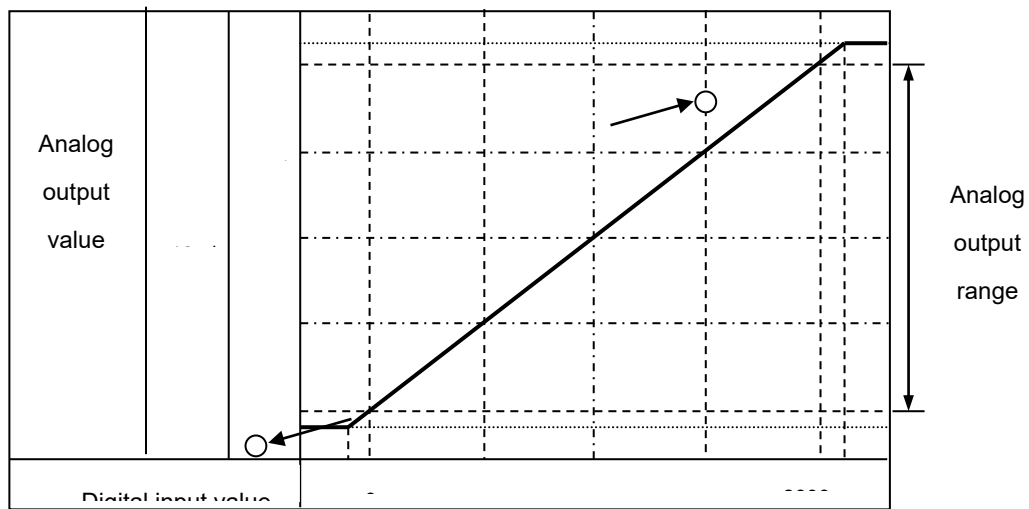

[Figure 9.9] I/O transformation characteristic (Output range: 0~20 mA, 4~20mA)

9.2.4 I/O Output when error occurs

- You can designate output status according to setting and status present analog value as follows, when error occurs.

Mode switch (HOLD)		output status	-10~10V	0~10V	0~5V	1~5V
Off	Off	0	0V	0V	0V	0V
Off	On	Max. value	10V	10V	5V	5V
On	Off	Min. value	-10V	0V	0V	1V
On	On	Previous value	Previous value			

Remark

- 1) You should turn off the power when changing mode switch.
- 2) You can't designate output status when error occurs and set status is applied to all channels commonly.
- 3) Designation switch is located in the upper body of module when error occurs as follows.

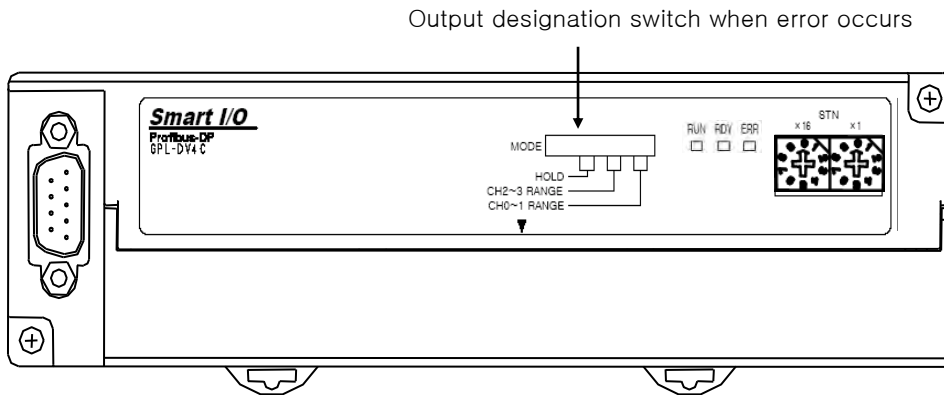

9.2.5 Installing

(1) Terminal block

1) GPL-DV4C

ANALOG VOLTAGE OUTPUT: 0~5, 1~5, 0~10, -10~10V

DC 24G	DC 24G	NC	NC	NC	NC	NC	NC	NC	NC	CH0 V+	CH1 V+	CH2 V+	CH3 V+	NC	NC	NC	NC	NC	NC
SG	NC	NC	NC	NC	NC	NC	NC	NC	NC	CH0 V-	CH1 V-	CH2 V-	CH3 V-	NC	NC	NC	NC	NC	NC

2) GPL-DC4C

ANALOG CURRENT OUTPUT: 4~20, 0~20mA

DC 24G	DC 24G	NC	NC	NC	NC	NC	NC	NC	NC	CH0 I+	CH1 I+	CH2 I+	CH3 I+	NC	NC	NC	NC	NC	NC
SG	NC	NC	NC	NC	NC	NC	NC	NC	NC	CH0 I-	CH1 I-	CH2 I-	CH3 I-	NC	NC	NC	NC	NC	NC

(2) Notice in wiring

- 1) Do not put AC power line near external signal line of analog input module.
You should maintain enough distance so you can escape effect of induction noise from AC power.
- 2) When choosing the wire, you consider near temperature, current. We recommend bigger than AWE22(0.3mm²) size wire. (including AWE22(0.3mm²) size wire)
- 3) If you expose wire to high temperature, it may cause error or damage because of short or ground.
- 4) When wiring terminal block, check polarity.
- 5) If you install wire near the high voltage line, it may cause error or damage because of induction obstacle.

(3) Wiring example

1) GPL-DV4C

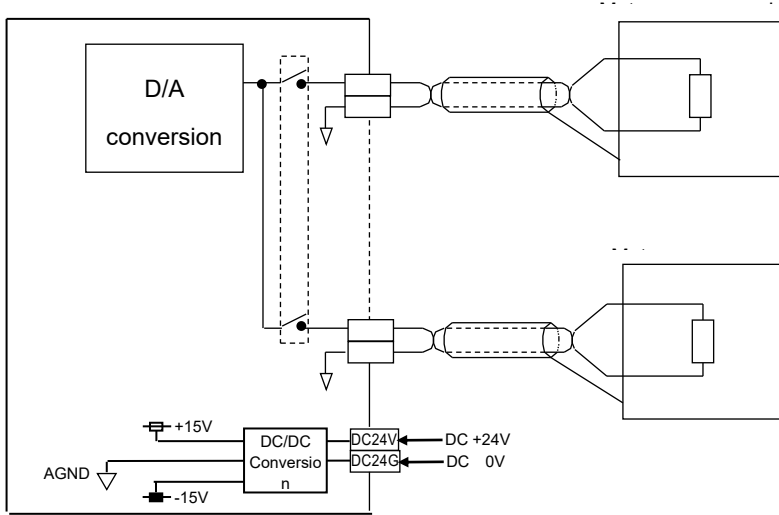

2) GPL-DC4C

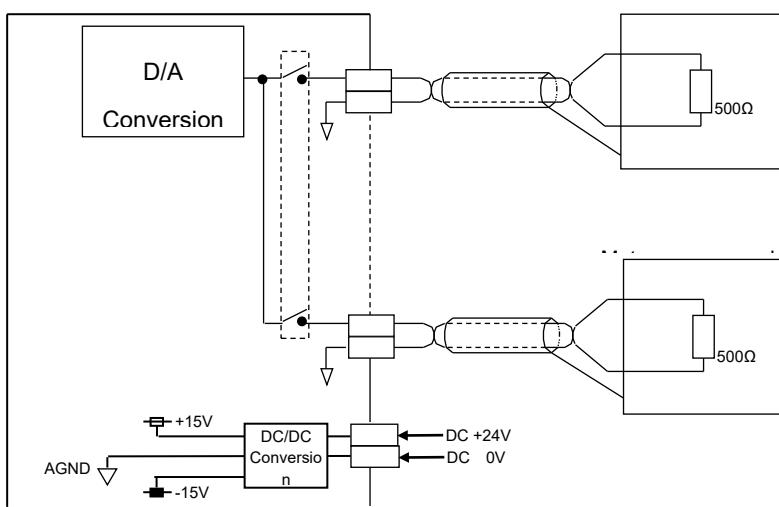

Use 2 core wire twisted-shield.
 We recommend bigger than AWE22(0.3mm²) size wire.
 (including AWE22(0.3mm²) size wire)

9.2.6 Example of program

(1) When using GLOFA Pnet master module

1) SyCon setting method

-To set SyCon, refer to the 5.3.3.

2) GMWIN setting method

A) High Speed Link setting method

- Open GMWIN's High Speed Link window.

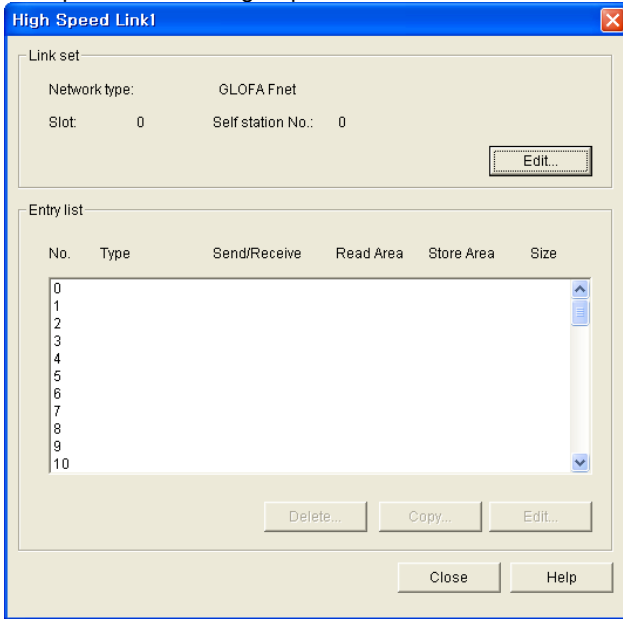

- Press [Edit] and designate slot location where Pnet master is equipped after choosing GLOFA Pnet.

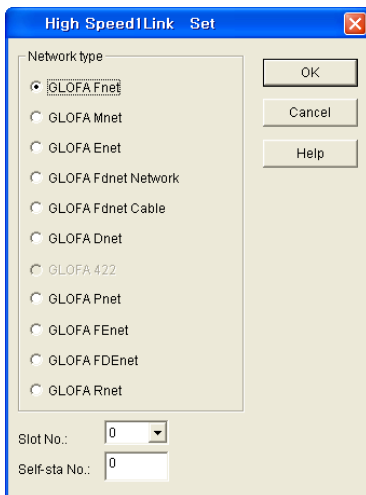

- Double-click registration list and set the area where digital value for transmitting is located.

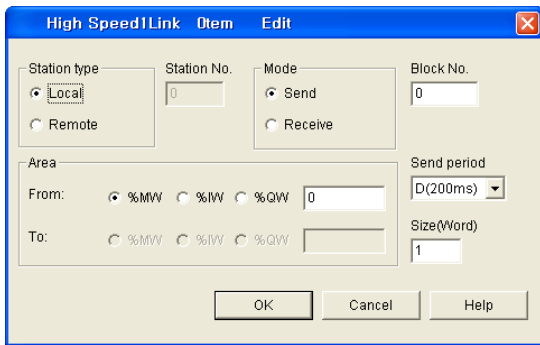

- Analog output module uses 2 byte per channel and one analog output module is 8 byte.

B) Analog output value and digital input value in GMWIN

- To input digital value in receiving area assigned at High Speed Link, use MOV function etc or assign M area after declaring value.

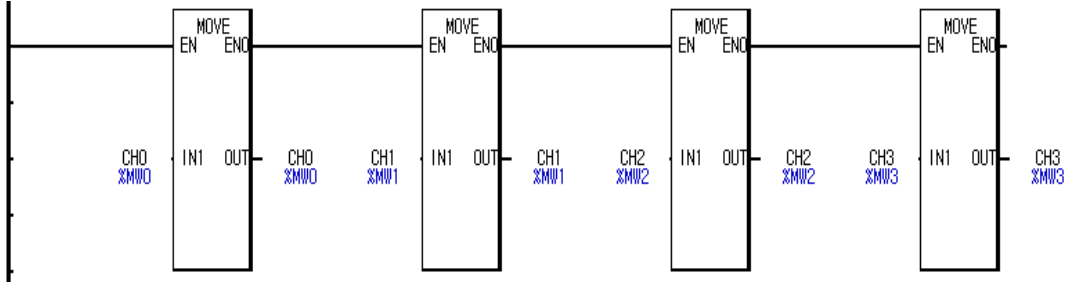

< Example of MOV function use >

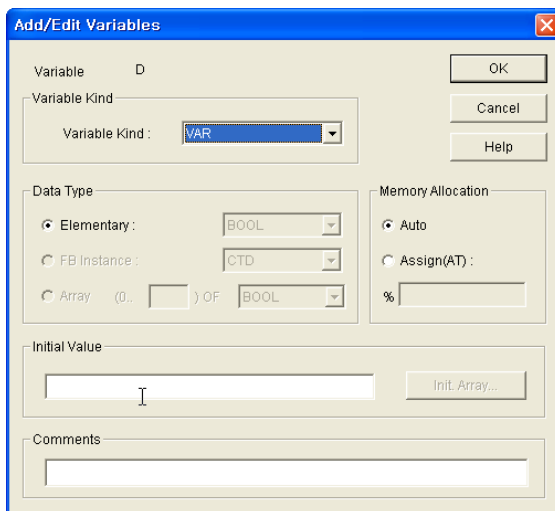

< Example of value use >

(2) When using MASTER-K Pnet master module

1) SyCon setting method

- To set SyCon, refer to the Ch. 5.3.3.

2) KGLWIN setting method

A) High Link setting method

- Open the KGLWIN's parameter window.

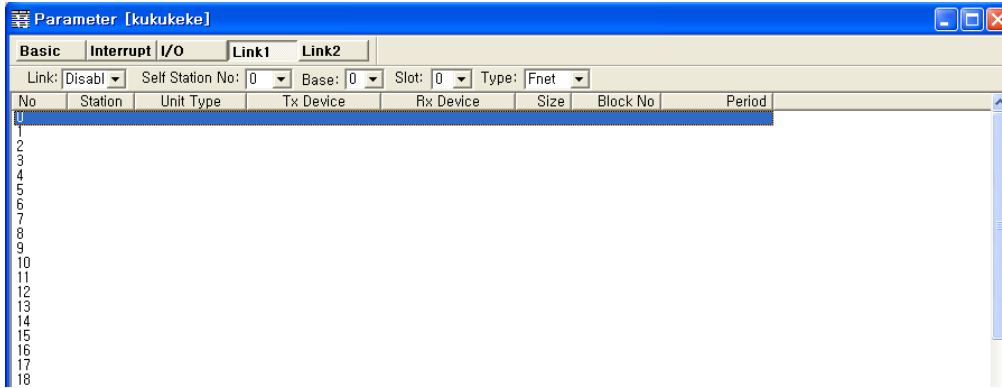

- Open the setting window by double-clicking the category.

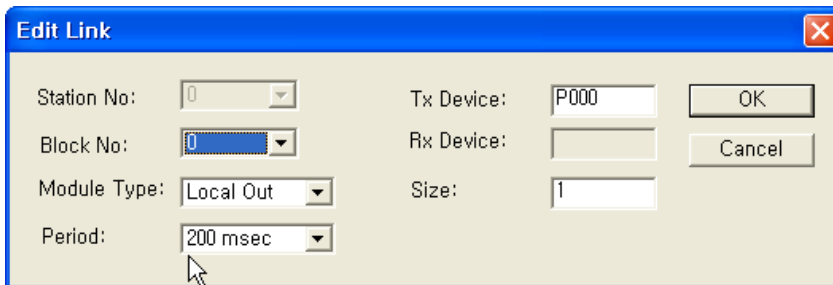

- Double-click registration list and set the area where digital value for transmitting is located.

- Analog output module use 2 byte per channel and one analog output module is 8 byte and 4 channels.

B) Input analog output digital value in KGLWIN

- The following is simple example which conveys digital value in D0 to M0 area set in parameter to yield digital value as analog value.



9.3 Checking Error

9.3.1 Type of error

Type of error	RDY LED status	Cause of error	Measures
Severe trouble	200ms flicker	Breakdown of module	Request A/S
Error in setting current range	0.5s flicker	1. It is available to set the input range of GPL-AC8C from -20mA to 20mA, 0~20mA, 4~20mA. But setting the mode switch as ON/ON may cause excess of input range. 2. It is available to set input range of GPL-DC4C from 0mA to 20mA, 4~20mA. But setting the mode switch as ON/OFF or ON/ON may cause excess of input range.	Refer to the Ch.9.3.2
Excess of digital input value range	1s flicker	Digital input value range has redundancy more than real use value as follows. -8000~8000 -> -8096~8095 0 ~ 8000 -> -96 ~8095 0 ~ 4000 -> -48 ~4047 But if input value exceeds the above range, it may cause error.	Refer to the Ch.9.3.2

9.3.2 Checking error

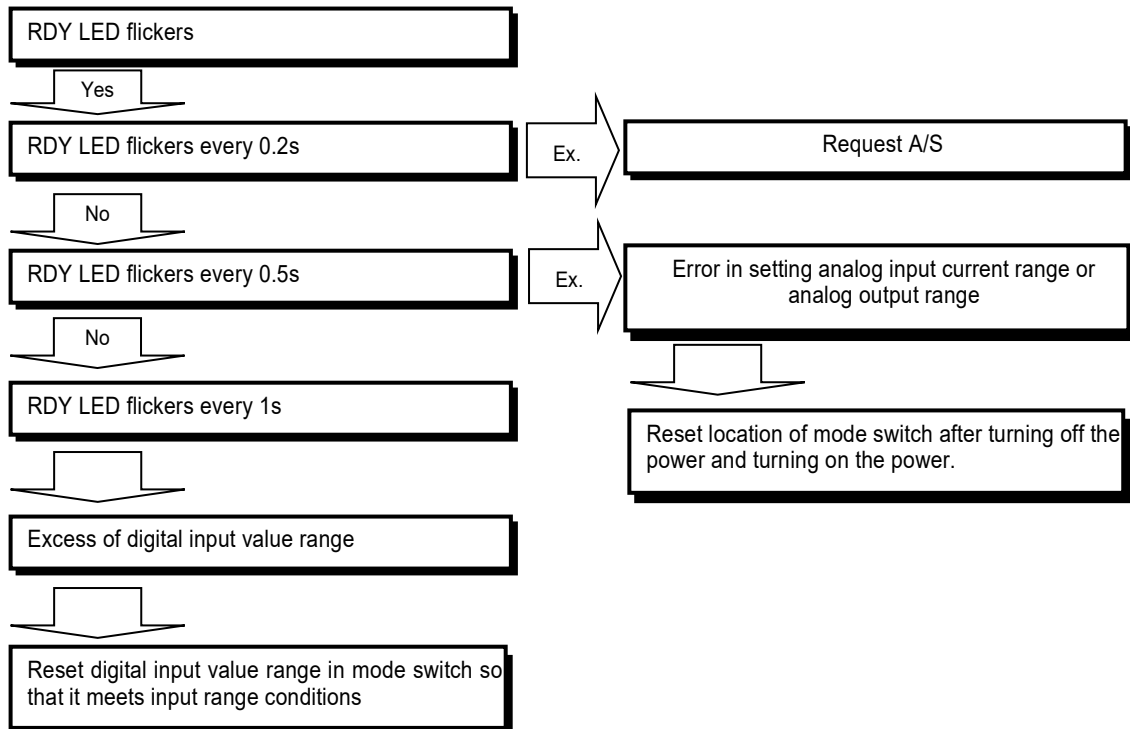

9.3.3 RDY LED is extinguished.

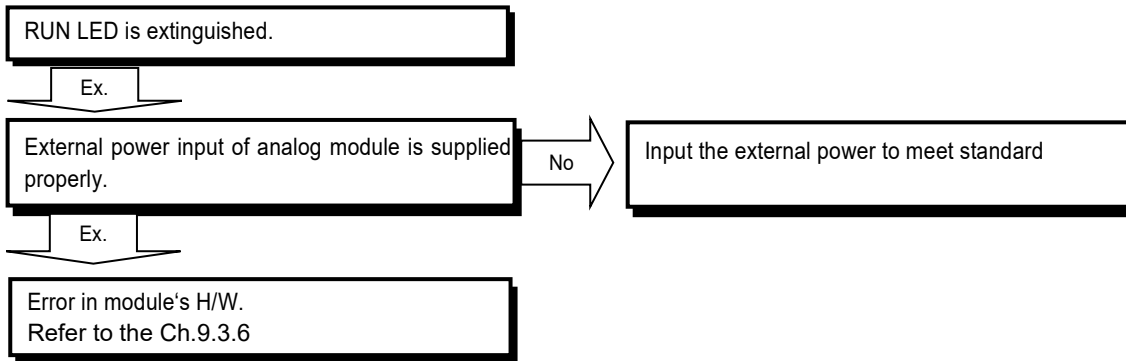

9.3.4 CPU module can't read transformation value.

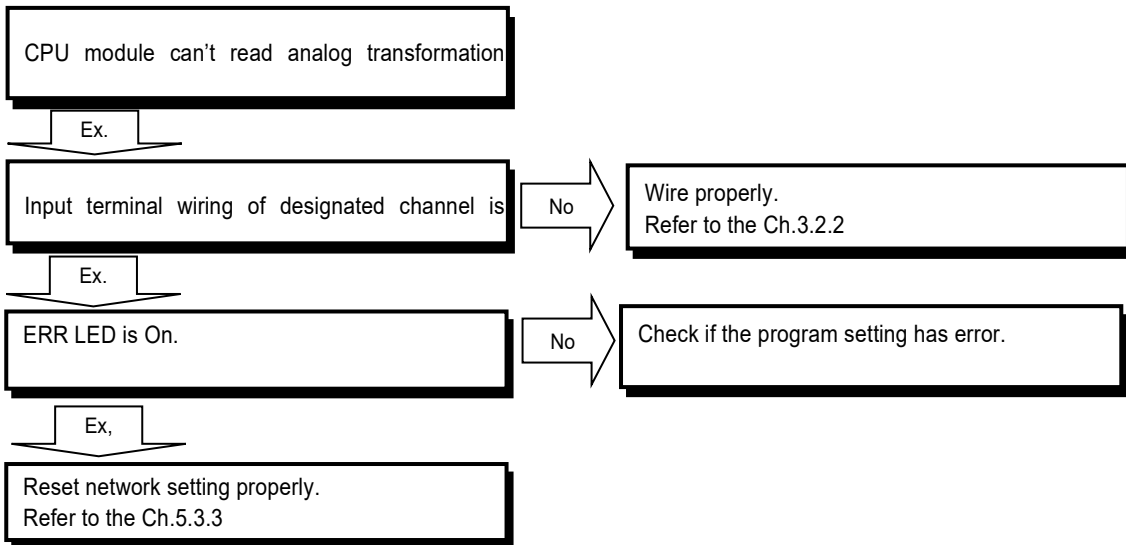

9.3.5 Analog value's relation is not consistent with digital value.

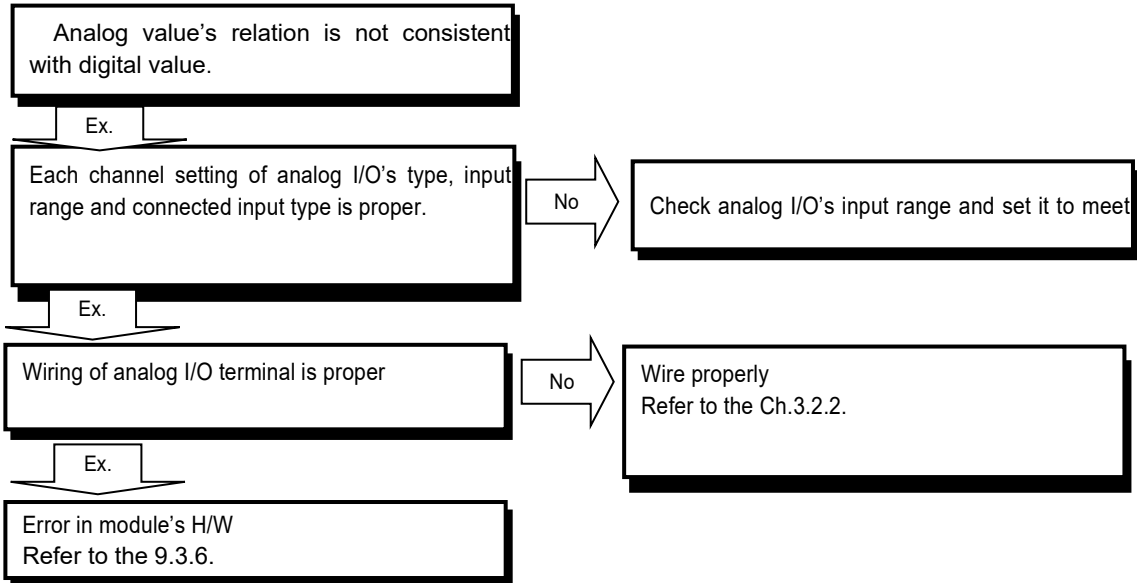

9.3.6 Breakdown in hardware of analog module.

Turn On/Off power again.
If trouble is continuous, request customer service center.

Chapter10 Ethernet Communication

10.1 Introduction

Ethernet is a 'technical standard' issued by IEEE, a world-wide entity. Using CSMA/CD method, it can collect a large capacity of data in a high speed as well as build a network easily by controlling communication.

Smart I/O Enet module has the following characteristics;

- Support IEEE 802.3 Standard
- Support 10/100BASE-TX media
- Accessible to the system thorough public network
- Support Ethernet Electricity 2 Ports (RJ-45)
- Available to run separately from each other because 2-channel Ethernet MAC is mounted
- Support Auto-Negotiation / Auto-Crossover function
- Support topology: Bus, Star
- Support communication protocol: Modbus/TCP, EtherNet/IP

10.2 Communication Dimension

Item	Performance Dimension
Data Transmission Speed	10/100Mbps
Transmission System	Base Band
Standard	IEEE 802.3
Flow Control	Full-duplex/half-duplex
Modulation	NRZI
Max length between nodes	100m
Max protocol size	1500byte
Access to communication zone	CSMA/CD
Check method for frame error	CRC32
Connector	RJ-45 (2-port)
IP Setting	S/W Setting
Topology	Bus, Star
communication protocol	Modbus/TCP, EtherNet/IP
Max digital in/output score	256 scores
Max number of extension digital modules to be connected to	8set
Max number of extension analog modules to be connected to	8set
Occupation Score of extension analog modules	8byte

10.3 Module Parameter Setting

10.3.1 BootpServer

Smart I/O Enet module, as a slave module, needs to set up IP Address, Subnet Mask, and Gateway Address to communication with the master module. .

To set up parameters of Smart I/O Enet module, BootpServer program shall be used.

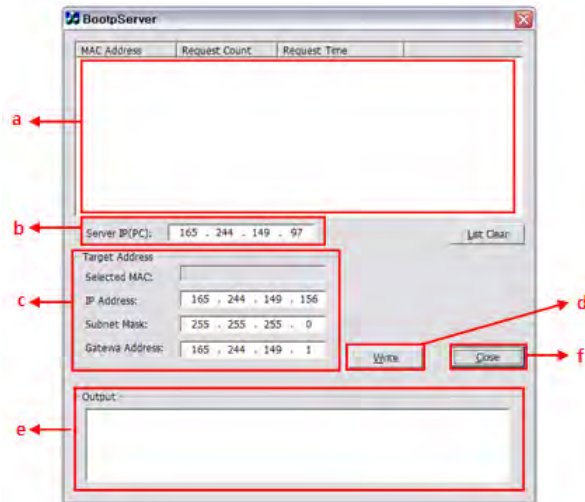

[Description of BootpServer Screen]

- a: Bootp Module List Window – A list of Bootp service support devices connected to PC is displayed.
- b: PC IP Address Window - IP Address of the user's PC is displayed.
- c: Parameter Setting Window - Communication parameters of a target device are set up.
- d: Write Button – Parameter Writing is executed.
- e: Output Window – The results of parameter settings are displayed.
- f: Close Button – The program is ended.

10.3.2 Parameter setting

Confirm the power of Smart I/O Enet module and connect to the user's PC with Enet cable.

MAC Address	Request Count	Request Time	
00:e0:91:03:0d:6a	3	10:44:00	

Check and select MAC Address of Smart I/O Enet module to be set up from the Bootp module list window.

Target Address

Selected MAC: 00:e0:91:03:0d:6a

IP Address: 165 . 244 . 149 . 156

Subnet Mask: 255 . 255 . 255 . 0

Gatewa Address: 165 . 244 . 149 . 1

Enter IP Address, Subnet Mask and Gateway Address setting values on the parameter setting window.

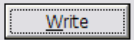

Press Write button to download parameter to Smart I/O Enet module.

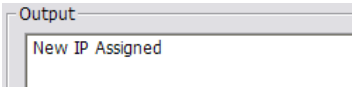

Check "New IP Assigned" message on the output window.

10.3.3 Check points before running BootpServer.

- (1) Program allowance in the Windows Firewall.
 - (a) Select Windows Firewall in the Control Panel.

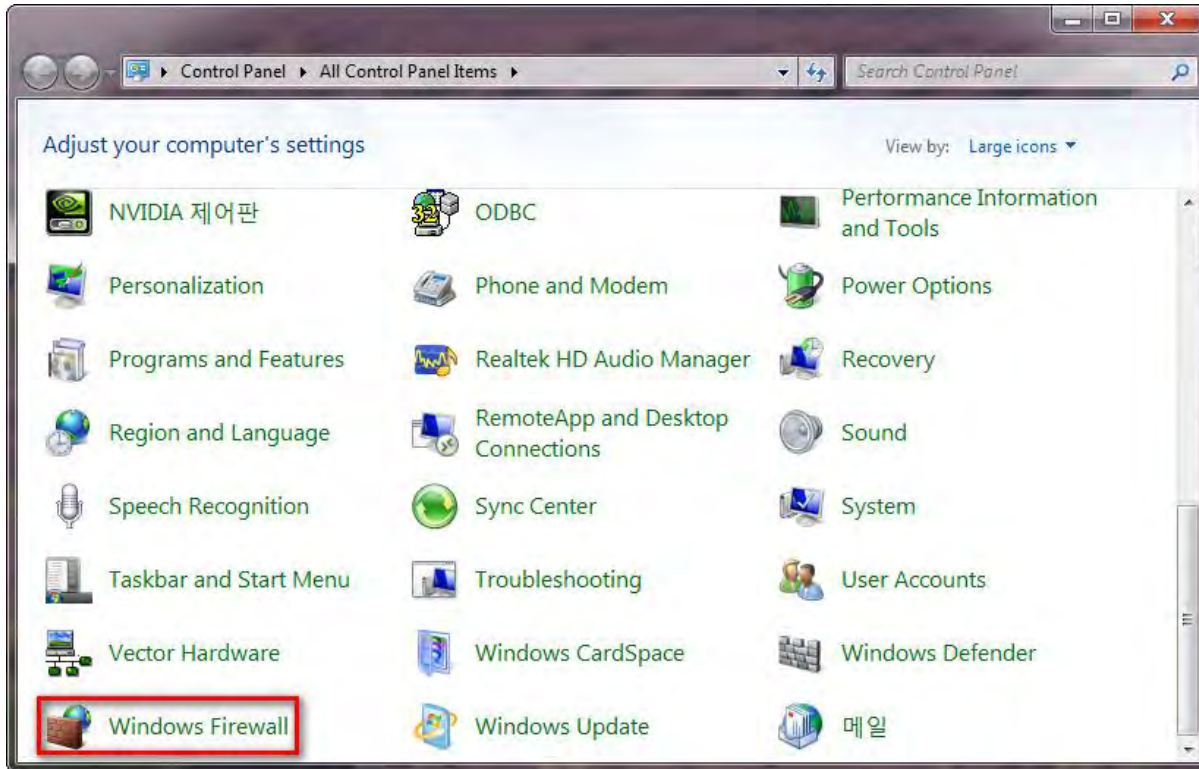

- (b) Select Allow a program or feature through Windows Firewall.

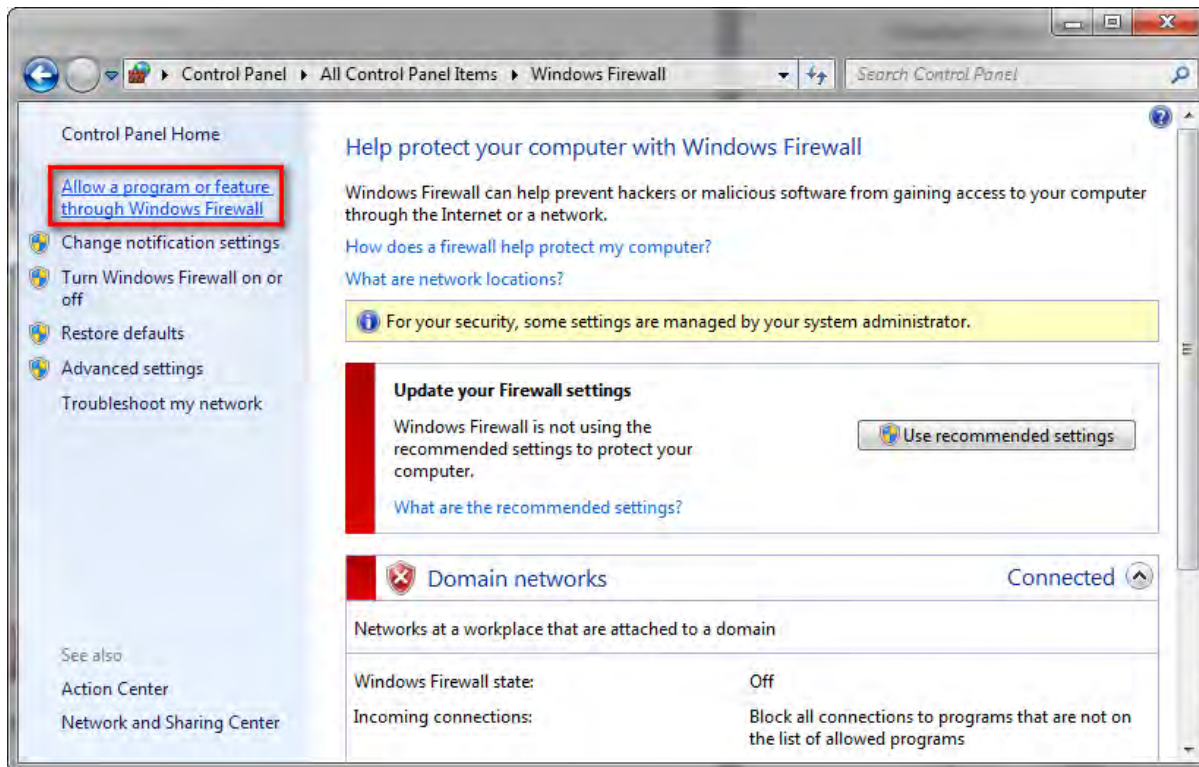

(c) Select Allow another program.

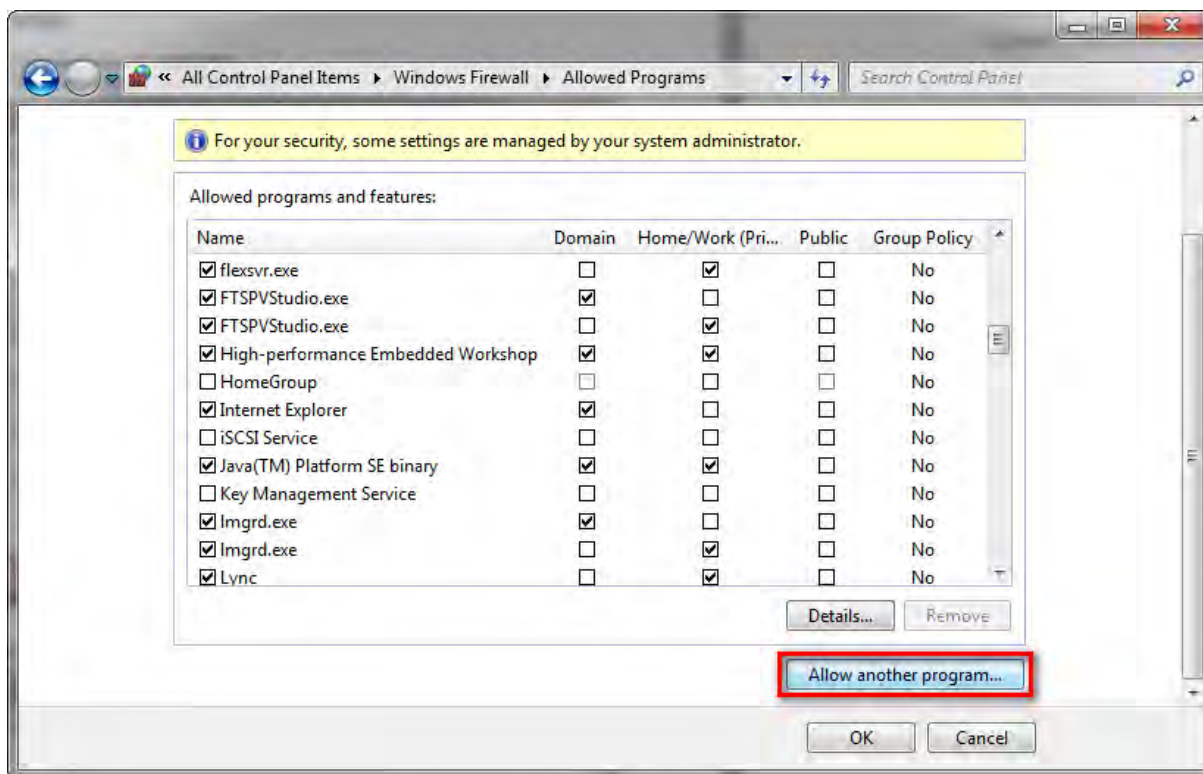

(d) Select Browse and check the path of BootpServer execution file.

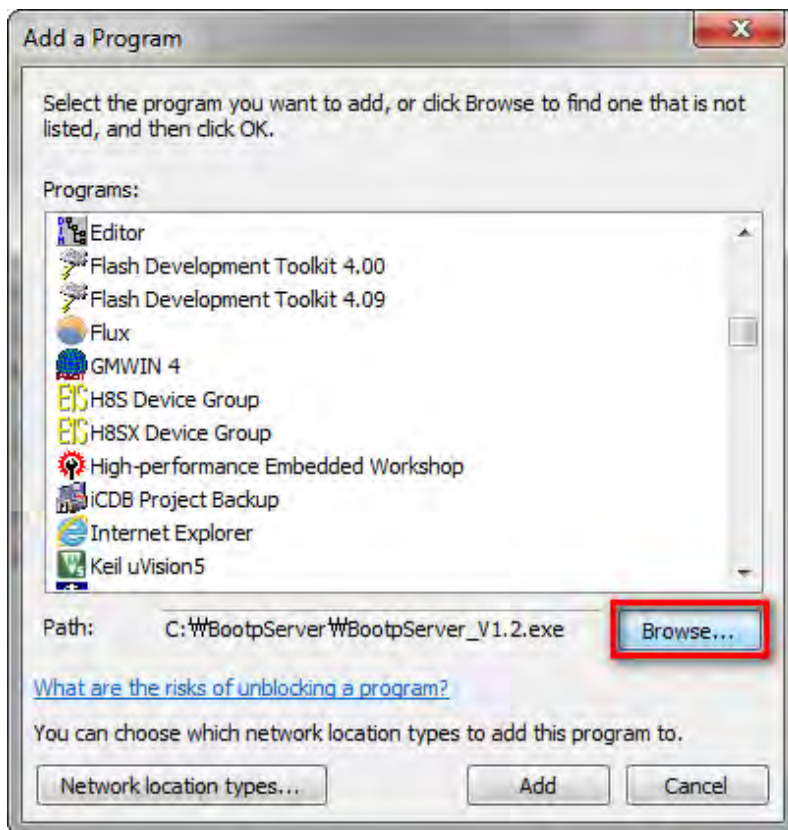

(2) Disable unused LAN card

(a) Select Network and Sharing Center in Control Panel

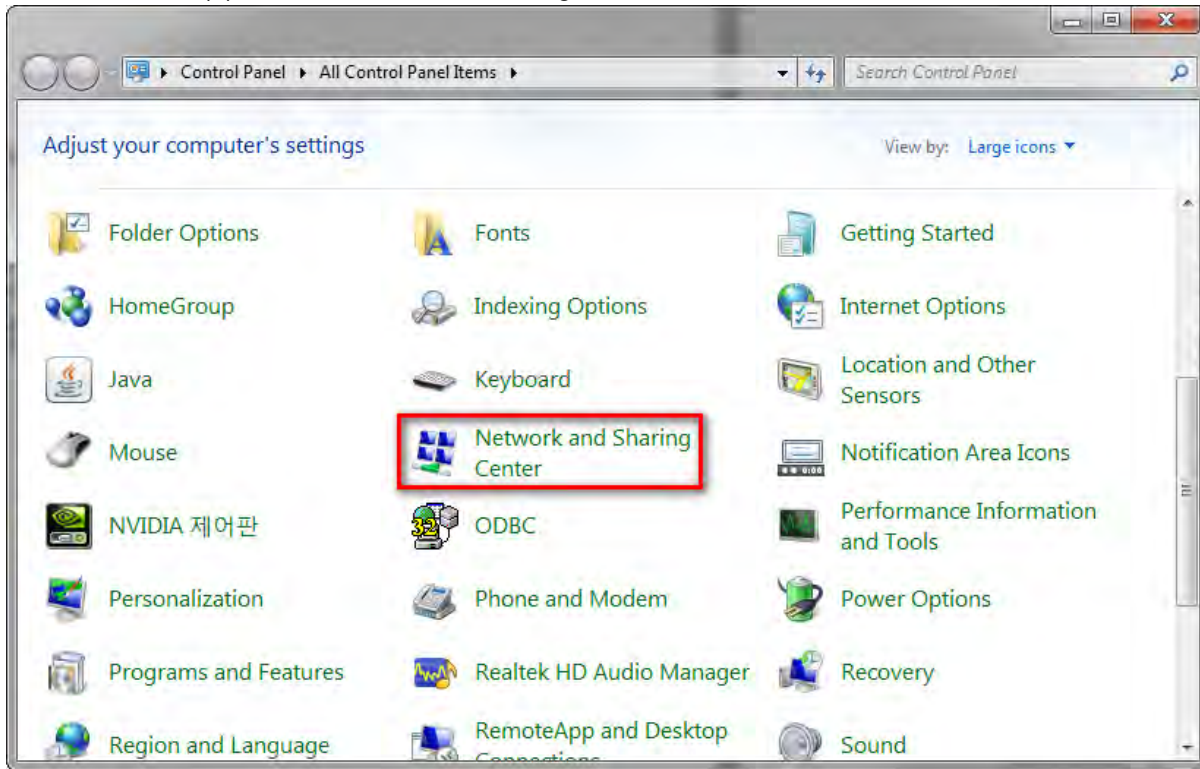

(b) Select Change adapter settings

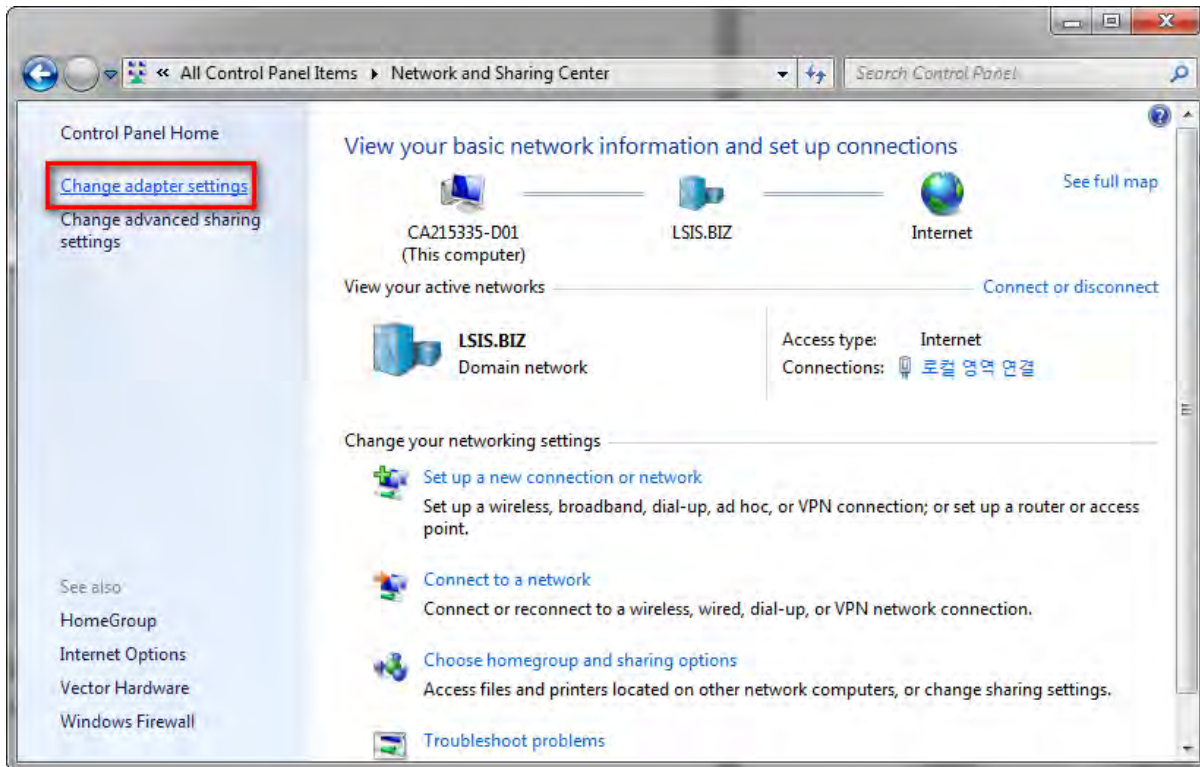

(c) Disable unused LAN cards with BootServer.

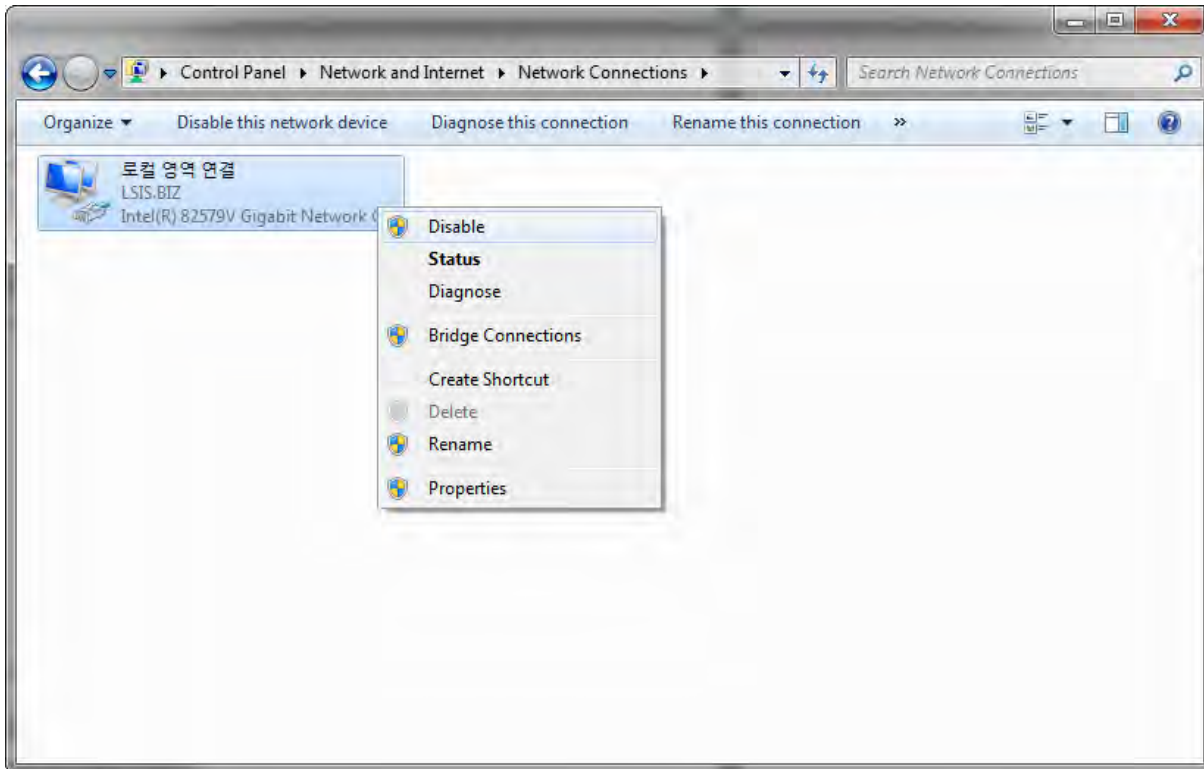

Note

(1) Do not set DHCP on your local LAN card when using BootServer

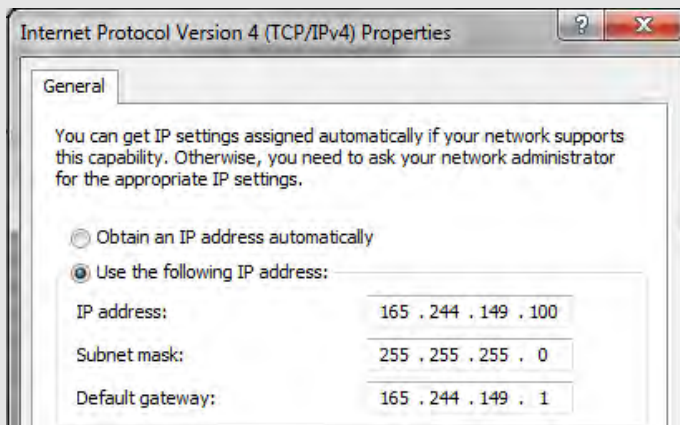

10.4 Modbus/TCP communication

10.4.1 I/O data assignment

- (1) Input data and output data are separated.
- (2) I/O Addresses are assigned automatically in order of being mounting to the adapter from Address 0 to 1, 2, 3 and etc.
- (3) Example of data assignment

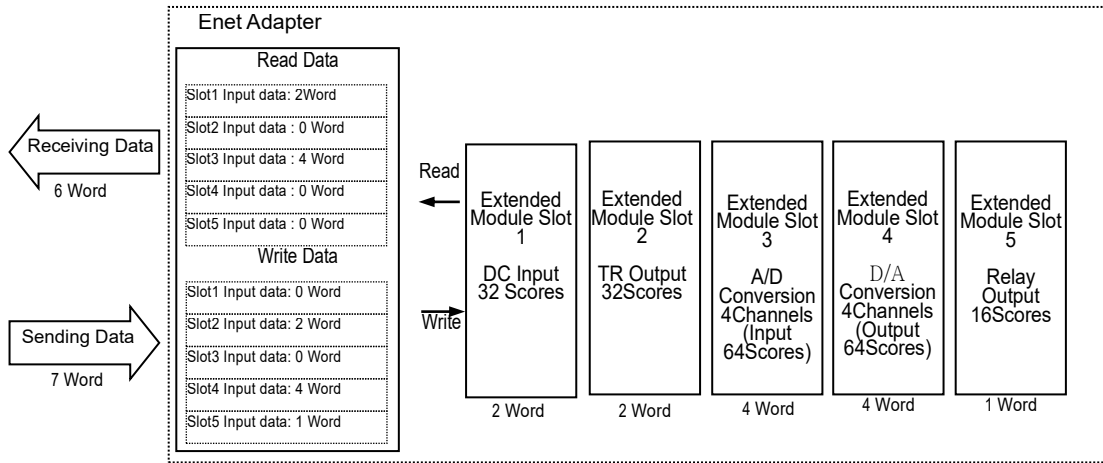

Receiving Data (Slave -> Master)				Sending Data (Master -> Slave)			
Address	Data Size	Extension Input Module		Address	data Size	Extension Output Module	
0	2Word	DC Input 32 scores		0	2Word	TR Output 32 scores	
1							
2	6Word	A/D Conversion 4CH	CH0	2	7Word	D/A Conversion 4CH	CH 0
3			CH 1	3			CH 1
4			CH 2	4			CH 2
5			CH 3	5			CH 3
				6	1Word	Relay Output 16 scores	

- (4) How to set up extension module parameter
 - (a) The extension modules mounted on Smart I/O Enet module are assigned with Word Address of 2-Word parameter setting area, which starting from 0x100 without distinguishing input modules from output modules.
(When 8 modules are mounted, 0x100~0x10F is assigned)
 - (b) Parameter setting is available with Read/Write commands-Modbus Words.
 - (c) Set up parameter read/writ block on XG5000
 - 1) Read/Write Block setting is equal to data communication setting.
 - 2) Only words are selectable for data type (Since parameters of a module shall be set up at the same time, parameter Read/Write consists of multiple numbers of data at least more than 2 words).
 - 3) It impossible to Read or Write both data and parameter on the same block.
 - 4) For parameter setting values of extension modules, refer to Appendix A.6.1.

10.4.2 Communication Setting

To communication with Smart I/O Enet module, first, download basic parameter of Smart I/O Enet module, then set up the Master module's communication parameter and P2P parameter.

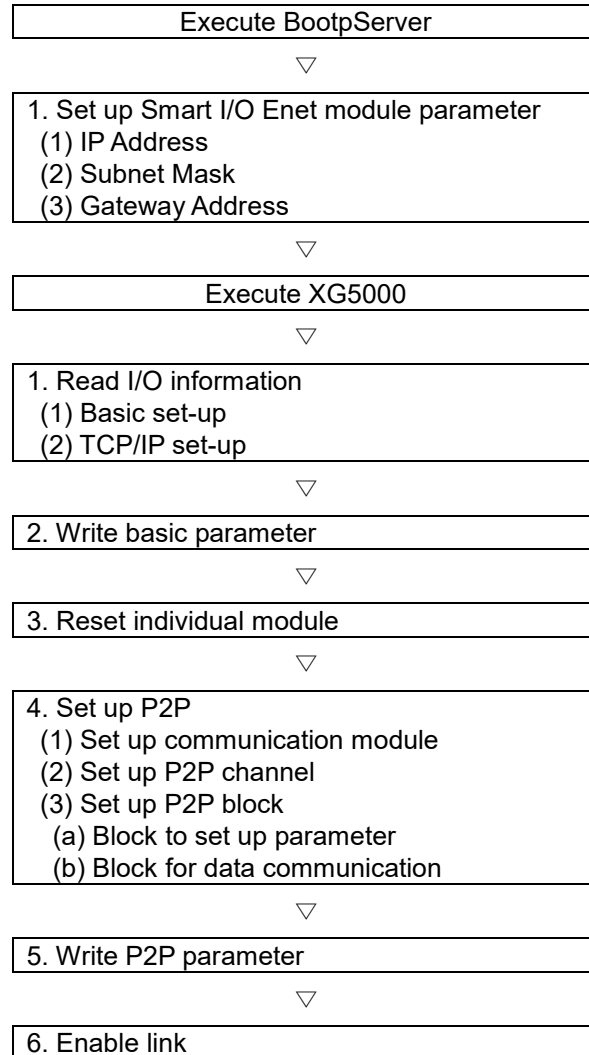

Note

When set the XBL-BSSA P2P data block, please note that as below

- (1) Modbus TCP can use bit or word type data only. So, there will be problem if you mount the byte type module to first or in the middle. (such as XBE-RY08A, TN08A, DC08A, DR16A)
- (2) The example of setting byte type module

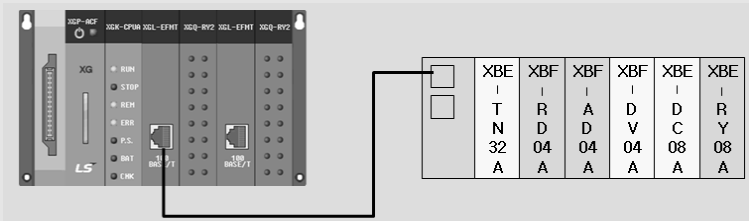

- a) I/O configuration
 - Input: 17 bytes
 - Output: 13 bytes
- b) Size of parameter block setting: 12words
- c) Data communication block setting
 - (a) Input module (RD04A, AD04A,DC08A): Read word type(8words) and bit type (8bits) of 17 bytes data
 - Read word type: 0x30000~0x30007
 - Read bit type: 0x10080~0x10087
 - (b) Output module (TN32A, DV04A,RY08A): Write word type(6words) and bit type(8bits) of 13bytes data
 - Write word type: 0x40000~0x40005
 - Write bit type: 0x00060~0x00067
 - (c) Parameter setting: 2words of each module
 - Word type: 0x40100~0x4010B(12words)

10.4.3 XGT Series communication

Ex) It has the following basic configuration and setting values:

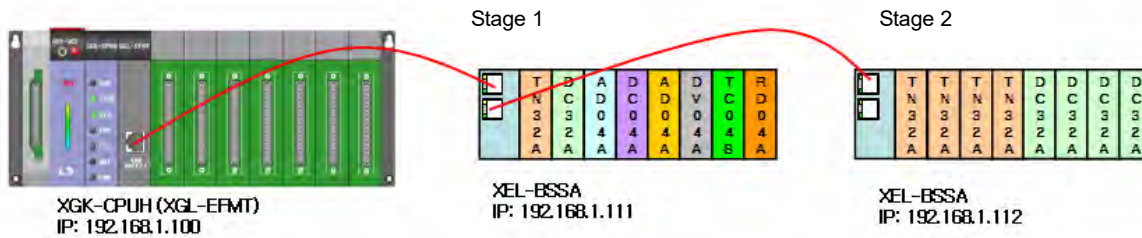

Setting Item		Description		Setting program	
Master	Master setting		XGL-EFMT		XG5000
	Base Number		0		XG5000
	Slot Number		0		XG5000
	TCP/IP setting	IP Address	192.168.1.100		XG5000
		Subnet Mask	255.255.255.0		
		Gateway Address	192.168.1.1		
	P2P Channel setting		Mode Bus TCP Client		XG5000
	P2P Trigger		20ms clock		XG5000
	P2P Way		Continual		XG5000
Data Type		Word		XG5000	
Slave	Block 1	module parameter setting	IP Address	192.168.1.111	BootpServer
			Subnet Mask	255.255.255.0	
			Gateway Address	192.168.1.1	
		Reading Block	Device	D00000	XG5000
			Size	18	
		Saving Block	Device	D00100	XG5000
	Size		10		
	Parameter Setting Block	Device	D00500	XG5000	
		Size	16		
	Block 2	Module Parameter Setting	IP Address	192.168.1.112	BootpServer
			Subnet Mask	255.255.255.0	
			Gateway Address	192.168.1.1	
		Reading Block	Device	D00200	XG5000
			Size	8	
		Saving Block	Device	D00300	XG5000
Size	8				
Parameter Setting Block	Device	D00600	XG5000		
	Size	16			

[BootpServer – Step1] Smart I/O Enet module parameter setting

Step	Item	Screen Configuration and Setting									
1-1	Run BootpServer	<p>Check Bootp module list</p> <table border="1"> <thead> <tr> <th>MAC Address</th> <th>Request Count</th> <th>Request Time</th> </tr> </thead> <tbody> <tr> <td>00:e0:91:03:0d:6b</td> <td>3</td> <td>19:28:33</td> </tr> <tr> <td>00:e0:91:03:0d:6a</td> <td>3</td> <td>19:30:29</td> </tr> </tbody> </table> <p>Select module to be set up</p>	MAC Address	Request Count	Request Time	00:e0:91:03:0d:6b	3	19:28:33	00:e0:91:03:0d:6a	3	19:30:29
MAC Address	Request Count	Request Time									
00:e0:91:03:0d:6b	3	19:28:33									
00:e0:91:03:0d:6a	3	19:30:29									
1-2	Input parameter setting value	<p>Target Address</p> <p>Selected MAC: 00:e0:91:03:0d:6b</p> <p>IP Address: 192 . 168 . 1 . 112</p> <p>Subnet Mask: 255 . 255 . 255 . 0</p> <p>Gatewa Address: 192 . 168 . 1 . 1</p>									
1-3	Download parameter	<p><input type="button" value="Write"/> Select Write button</p>									
1-4	Confirm completion of parameter setting	<p>Output</p> <p>New IP Assigned</p> <p>Check output window</p>									
1-5	Set up extension block 2 module	Repeat 1-1 ~ 1-4									

[XG5000 - Step1] Program Creation

Menu Selection: File – New File

Step	Item	Screen Configuration and Setting
1-1	Set up program name	Project name: <input type="text" value="adapter"/>
1-2	Specify file location	File directory: <input type="text" value="C:\XG5000\source\adapter"/>
1-3	Select PLC Series	<p>PLC Series</p> <p><input checked="" type="radio"/> XGK <input type="radio"/> XGB <input type="radio"/> XGI <input type="radio"/> XGR</p> <p>Select XGK</p>
1-4	Select CPU Kind	<p>CPU type: <input type="text" value="XGK-CPUH"/> <input type="button" value="v"/></p> <p>Select XGK-CPUH</p>
1-5	Complete creation program	<p><input type="button" value="OK"/> Select OK button</p>

[XG5000 - Step2] Communication Method Setting

Menu Selection: Online – Connection Setting

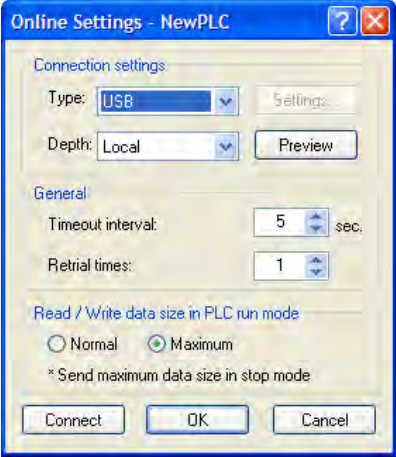
Step	Item	Screen Configuration and Setting
2-1	Set up communication method	 <p>Connection Method: USB Connection Step: Local</p>

[XG5000 - Step 3] Connection

Menu Selection: Online – Connection

[XG5000 - Step 4] I/O Information Reading

Menu Selection: Online – Diagnosis – I/O Information – I/O sync

[XG5000 - Step 5] Master module TCP/IP setting

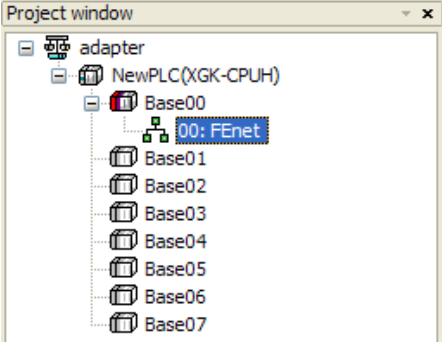
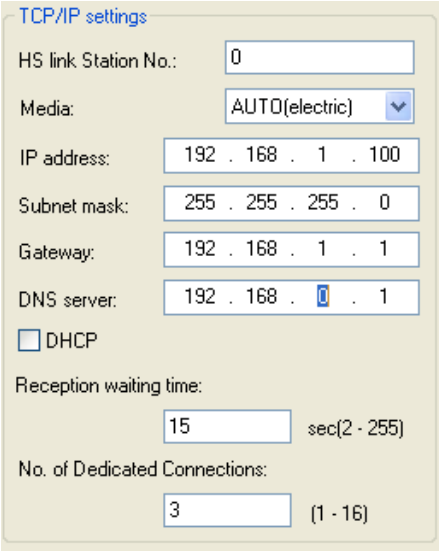
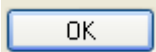
Step	Item	Screen Configuration and Setting
5-1	Set up Master module	 <p>Select Master module from basic setting tap and double click.</p>
5-2	Set up TCP/IP	 <p>IP Address: 192.168.1.100 Subnet Mask: 255.255.255.0 Gateway: 192.168.1.1 DNS Server, Waiting Time, Exclusive Connection Count: Setting suitable for user's environment</p>
5-3	Set up	 <p>Select OK button</p>

[XG5000 - Step 6] Basic setting parameter writing

Menu Selection: Online – Parameter Writing

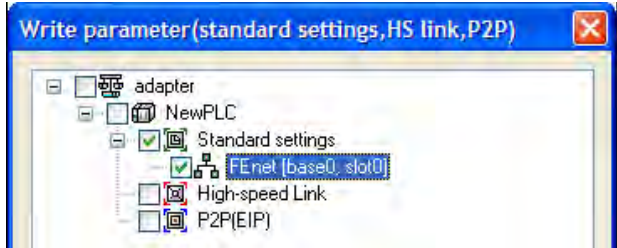
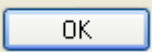
Step	Item	Screen Configuration and Setting
6-1	Select parameter writing	 <p>Select Master module</p>
6-2	Download parameter	 <p>Select OK button</p>

[XG5000 - 7] Individual module reset

Menu Selection: Online – Reset –Individual Module Reset

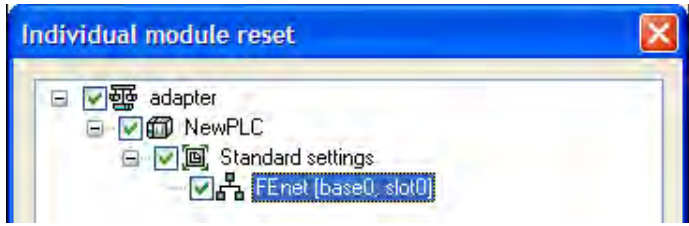
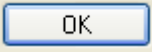
Step	Item	Screen Configuration and Setting
7-1	Select module	 <p>Select Master module</p>
7-2	Reset module	 <p>Select OK button</p>

[XG5000 - Step 8] P2P communication setting

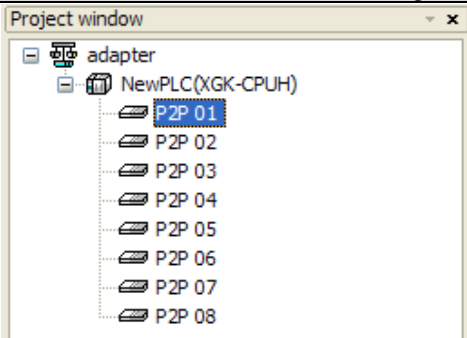
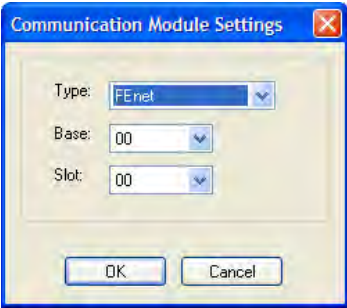
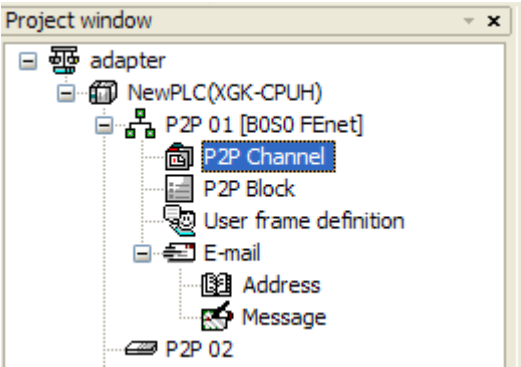
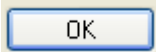
Step	Item	Screen Configuration and Setting																					
8-1	Register P2P	 <p>After selecting P2P NO.1 on P2P tap, double click it</p>																					
8-2	Set up P2P communication module	 <p>Kind: FEnet Base: 0 Slot: 0</p>																					
8-3	Register P2P Channel	 <p>After selecting P2P Channel, double click it</p> <table border="1" data-bbox="579 1659 1475 1749"> <thead> <tr> <th>Channe</th> <th>Operating Mode</th> <th>P2P Driver</th> <th>TCP/UDP</th> <th>Client/Server</th> <th>Partner Port</th> <th>Partner IP address</th> </tr> </thead> <tbody> <tr> <td>0</td> <td>XGT server</td> <td>Modbus TCP client</td> <td>TCP</td> <td>Client</td> <td>502</td> <td>192.168.1.111</td> </tr> <tr> <td>1</td> <td>XGT server</td> <td>Modbus TCP client</td> <td>TCP</td> <td>Client</td> <td>502</td> <td>192.168.1.112</td> </tr> </tbody> </table> <p>Register P2P Channel Channel0: Mode Bus TCP Client, Partner's National IP (Extension stage1) Channel1: Mode Bus TCP Client, Partner's National IP (Extension stage2)</p>  Select OK button	Channe	Operating Mode	P2P Driver	TCP/UDP	Client/Server	Partner Port	Partner IP address	0	XGT server	Modbus TCP client	TCP	Client	502	192.168.1.111	1	XGT server	Modbus TCP client	TCP	Client	502	192.168.1.112
Channe	Operating Mode	P2P Driver	TCP/UDP	Client/Server	Partner Port	Partner IP address																	
0	XGT server	Modbus TCP client	TCP	Client	502	192.168.1.111																	
1	XGT server	Modbus TCP client	TCP	Client	502	192.168.1.112																	

Step	Item	Screen Configuration and Setting																																																												
8-4	Set up P2P Block (Extension Module Parameter Setting Block)	<p>Parameter Setting Block</p> <table border="1"> <thead> <tr> <th>Index</th> <th>E-mail</th> <th>Ch.</th> <th>Driver Setting</th> <th>P2P function</th> <th>Conditional flag</th> <th>Command type</th> <th>Data type</th> <th>No. of variables</th> <th>Data size</th> </tr> </thead> <tbody> <tr> <td>0</td> <td><input type="checkbox"/></td> <td>0</td> <td>Modbus TCP client</td> <td>WRITE</td> <td>M00000</td> <td>Continuous</td> <td>WORD</td> <td>1</td> <td>16</td> </tr> <tr> <td>1</td> <td><input type="checkbox"/></td> <td>1</td> <td>Modbus TCP client</td> <td>WRITE</td> <td>M00001</td> <td>Continuous</td> <td>WORD</td> <td>1</td> <td>16</td> </tr> </tbody> </table> <p>Extension stage 1 parameter</p> <ul style="list-style-type: none"> - Writing Trigger: M00000 - data Size: 16Word - Set up Writing Block <table border="1"> <thead> <tr> <th>Read area</th> <th>Save area</th> <th>Address</th> </tr> </thead> <tbody> <tr> <td>D00500</td> <td>0x40000</td> <td>N00001</td> </tr> </tbody> </table> <p>Extension stage 2 parameter writing trigger M00001</p> <ul style="list-style-type: none"> - Writing Trigger : M00001 - Data Size: 16Word - Set up Writing Block <table border="1"> <thead> <tr> <th>Read area</th> <th>Save area</th> <th>Address</th> </tr> </thead> <tbody> <tr> <td>D00600</td> <td>0x40000</td> <td>N00042</td> </tr> </tbody> </table>	Index	E-mail	Ch.	Driver Setting	P2P function	Conditional flag	Command type	Data type	No. of variables	Data size	0	<input type="checkbox"/>	0	Modbus TCP client	WRITE	M00000	Continuous	WORD	1	16	1	<input type="checkbox"/>	1	Modbus TCP client	WRITE	M00001	Continuous	WORD	1	16	Read area	Save area	Address	D00500	0x40000	N00001	Read area	Save area	Address	D00600	0x40000	N00042																		
Index	E-mail	Ch.	Driver Setting	P2P function	Conditional flag	Command type	Data type	No. of variables	Data size																																																					
0	<input type="checkbox"/>	0	Modbus TCP client	WRITE	M00000	Continuous	WORD	1	16																																																					
1	<input type="checkbox"/>	1	Modbus TCP client	WRITE	M00001	Continuous	WORD	1	16																																																					
Read area	Save area	Address																																																												
D00500	0x40000	N00001																																																												
Read area	Save area	Address																																																												
D00600	0x40000	N00042																																																												
8-5	Set up P2P Block (Data Communication Block)	<p>Extension stage 1 communication setting</p> <table border="1"> <tbody> <tr> <td>0</td> <td>Modbus TCP client</td> <td>WRITE</td> <td>F00090</td> <td>Continuous</td> <td>WORD</td> <td>1</td> <td>10</td> </tr> <tr> <td>0</td> <td>Modbus TCP client</td> <td>READ</td> <td>F00090</td> <td>Continuous</td> <td>WORD</td> <td>1</td> <td>18</td> </tr> </tbody> </table> <p>Set up Writing Block</p> <table border="1"> <thead> <tr> <th>Read area</th> <th>Save area</th> <th>Address</th> </tr> </thead> <tbody> <tr> <td>D00000</td> <td>0x40000</td> <td>N00083</td> </tr> </tbody> </table> <p>Set up Reading Block</p> <table border="1"> <thead> <tr> <th>Read area</th> <th>Save area</th> <th>Address</th> </tr> </thead> <tbody> <tr> <td>0x30000</td> <td>D00100</td> <td>N00144</td> </tr> </tbody> </table> <p>Extension stage 1 communication setting</p> <table border="1"> <tbody> <tr> <td>0</td> <td>Modbus TCP client</td> <td>WRITE</td> <td>F00090</td> <td>Continuous</td> <td>WORD</td> <td>1</td> <td>8</td> </tr> <tr> <td>0</td> <td>Modbus TCP client</td> <td>READ</td> <td>F00090</td> <td>Continuous</td> <td>WORD</td> <td>1</td> <td>8</td> </tr> </tbody> </table> <p>Set up Writing Block</p> <table border="1"> <thead> <tr> <th></th> <th>Read area</th> <th>Save area</th> <th>Address</th> </tr> </thead> <tbody> <tr> <td>1</td> <td>D00200</td> <td>0x40000</td> <td>N00083</td> </tr> </tbody> </table> <p>Set up Reading Block</p> <table border="1"> <thead> <tr> <th></th> <th>Read area</th> <th>Save area</th> <th>Address</th> </tr> </thead> <tbody> <tr> <td>1</td> <td>0x30000</td> <td>D00300</td> <td>N00144</td> </tr> </tbody> </table>	0	Modbus TCP client	WRITE	F00090	Continuous	WORD	1	10	0	Modbus TCP client	READ	F00090	Continuous	WORD	1	18	Read area	Save area	Address	D00000	0x40000	N00083	Read area	Save area	Address	0x30000	D00100	N00144	0	Modbus TCP client	WRITE	F00090	Continuous	WORD	1	8	0	Modbus TCP client	READ	F00090	Continuous	WORD	1	8		Read area	Save area	Address	1	D00200	0x40000	N00083		Read area	Save area	Address	1	0x30000	D00300	N00144
0	Modbus TCP client	WRITE	F00090	Continuous	WORD	1	10																																																							
0	Modbus TCP client	READ	F00090	Continuous	WORD	1	18																																																							
Read area	Save area	Address																																																												
D00000	0x40000	N00083																																																												
Read area	Save area	Address																																																												
0x30000	D00100	N00144																																																												
0	Modbus TCP client	WRITE	F00090	Continuous	WORD	1	8																																																							
0	Modbus TCP client	READ	F00090	Continuous	WORD	1	8																																																							
	Read area	Save area	Address																																																											
1	D00200	0x40000	N00083																																																											
	Read area	Save area	Address																																																											
1	0x30000	D00300	N00144																																																											

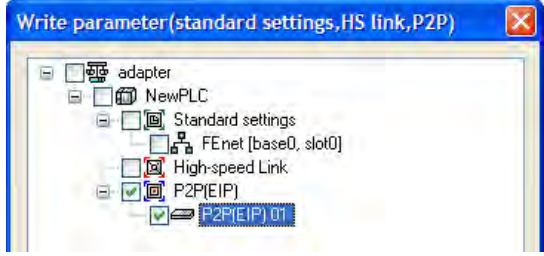
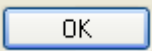

[XG5000 - 9Step] P2P setting writing

Menu Selection: Online – Parameter Writing

Step	Item	Screen Configuration and Setting
9-1	Select parameter writing	 <p>SELECT P2P NO.1</p>
9-2	Download P2P setting	 <p>Select OK button</p>

[XG5000 - Step 10] Link Enable

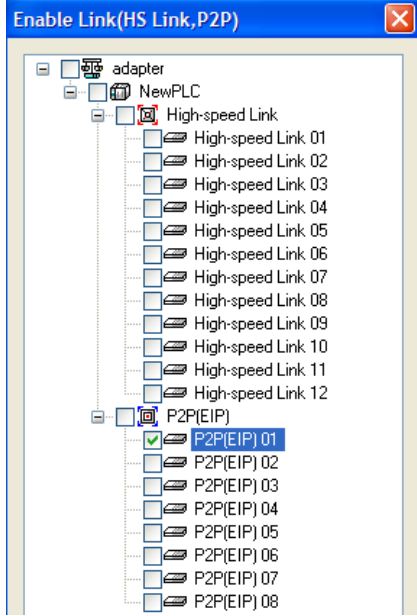
Menu Selection: Online – Link Enable

Step	Item	Screen Configuration and Setting
10-1	Set up Link Enable	 <p>SELECT P2P NO.1</p>
10-2	Set up Link Enable	 <p>Select Write button</p>

10.5 EtherNet/IP communication

10.5.1 I/O data assignment

- (1) Input data and output data are separated.
- (2) I/O Addresses are assigned automatically in order of being mounting to the adapter.
- (3) Example of data assignment

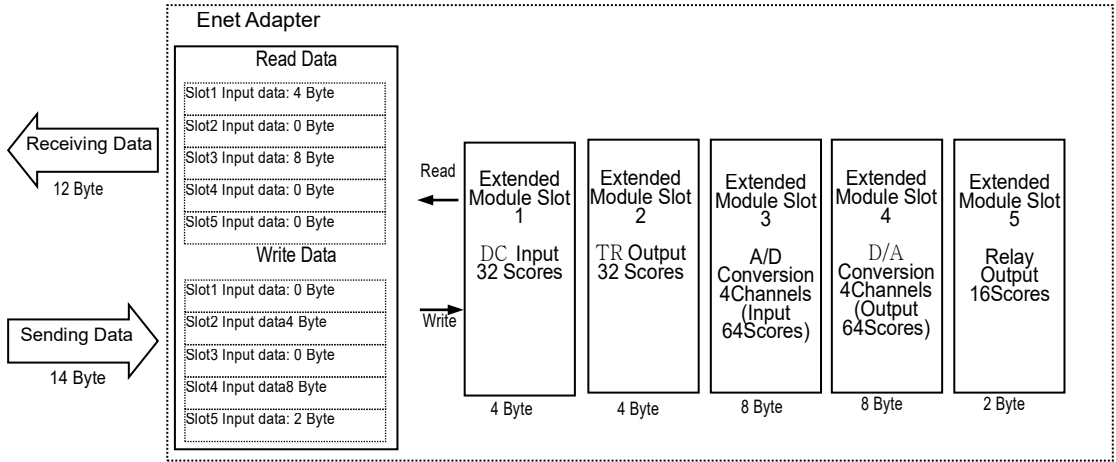

- (4) How to set up I/O module
 - (a) In case there are Input and Output module,

Item	Description	Vale
Transport Type	Originator → Target	Point To Point
	Target → Originator	Multicast
Connection Point (Assembly Instance)	Originator → Target	170(Decimal)
	Target → Originator	160(Decimal)
data Size(Byte)	Originator → Target	Adapter Output Size(Byte)
	Target → Originator	Adapter Input Size(Byte)

- (b) In case there is input module only,

Item	Description	Vale
Transport Type	Originator → Target	Point To Point
	Target → Originator	Multicast
Connection Point (Assembly Instance)	Originator → Target	128(Decimal)
	Target → Originator	160(Decimal)
data Size(Byte)	Originator → Target	-
	Target → Originator	Adapter Input Size(Byte)

(c) In case there is output module only,

Item	Description	Vale
Transport Type	Originator → Target	Point To Point
	Target → Originator	Multicast
Connection Point (Assembly Instance)	Originator → Target	170(Decimal)
	Target → Originator	160(Decimal)
data Size(Byte)	Originator → Target	Adapter Output Size(Byte)
	Target → Originator	1Byte

(5) How to set up extension module parameter

- (a) Extension module parameters of XEL-BSSB module are set up with Assembly Object through UCMM Message.
- (b) Parameter setting Assembly Object of XEL-BSSB module has Instance ID 180 (0xB4).
- (c) Parameter size of extension modules is 4 bytes per module.
- (d) Data size of parameter setting Assembly Object Instance is equal to the sum of parameter setting blocks of the extension module mounted on XEL-BSSB module.
- (e) New parameter can be applied only to XEL-BSSB module whose parameter values are changed when setting up parameter writing with UCMM Message.
- (f) For parameter setting values of extension modules, refer to Appendix A.7.1.

※ Example of UCMM Message

```

Service Code : 16 (0x10 : Set)
Class       : 04 (0x04 : Assembly Class)
Instance    : 180 (0xB4 : parameter setting Assembly Object )
Attribute   : 03 (0x03 : Data)
Data       : XX XX XX XX XX XX XX XX XX XX XX XX (parameter setting value)

```

(6) UCMM Communication

(a) Parameter setting

Description	Value
Service Code	16 (0x10)
Class	04 (0x04)
Instance	180 (0xB4)
Attribute	03 (0x03)
Data	Parameter setting value

(b) Send data

Description	Value
Service Code	16 (0x10)
Class	04 (0x04)
Instance	170 (0xAA)
Attribute	03 (0x03)
Data	Send data

(c) Receive data

Description	Value
Service Code	14 (0x0E)
Class	04 (0x04)
Instance	160 (0xA0)
Attribute	03 (0x03)
Data	Receive data

10.5.2 Communication Setting

To communication with Smart I/O Enet module, first, download basic parameter of Smart I/O Enet module, then set up Master module의 communication parameter and P2P parameter of the master module.

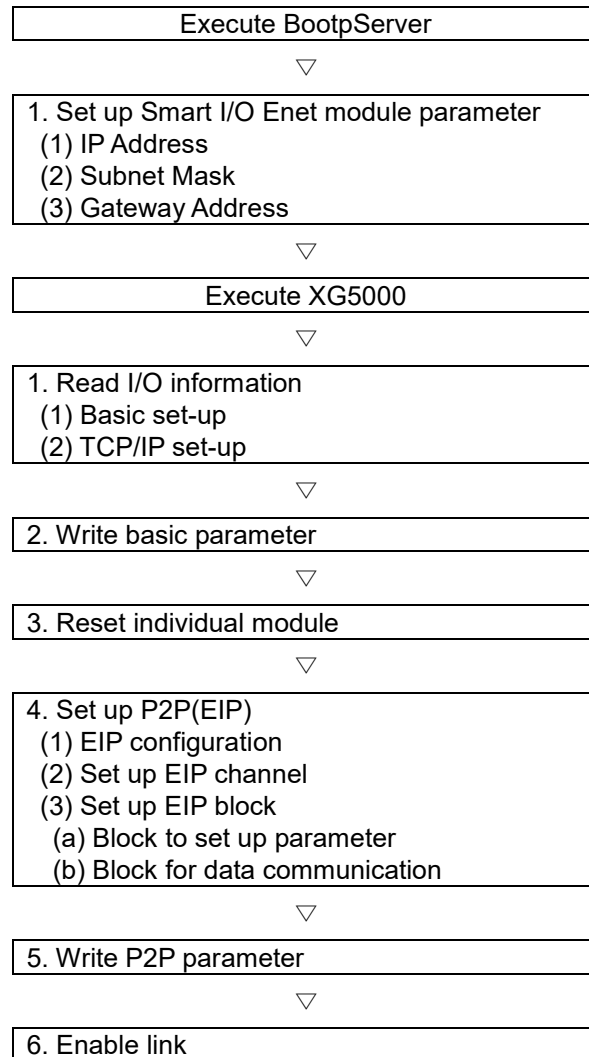

10.5.3 XGT Series Communication

Ex) It has the following basic configuration and setting values:

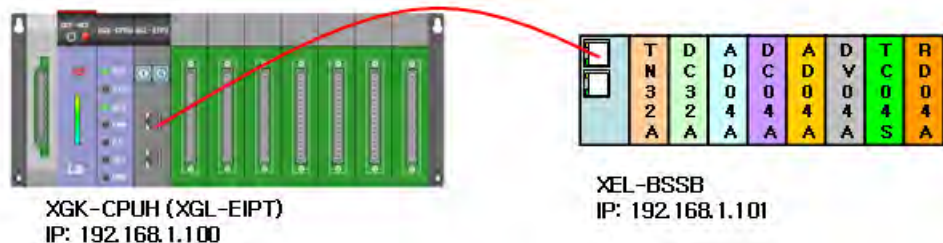

Setting Item		Description		setting program		
Master	Master setting	XGL-EIMT		XG5000		
	Base Number	0		XG5000		
	Slot Number	0		XG5000		
	Set up TCP/IP	IP Address	192.168.1.100		XG5000	
		Subnet Mask	255.255.255.0			
		Gateway Address	192.168.1.1			
	Non-periodic communication (Extension module parameter setting)	Device	D00200		XG5000	
		Size	32			
	Periodic communication	EDS Channel setting	Generic EtherNet/IP Module		XG5000	
		I/O Type	Exclusive Owner (8bit instance)		XG5000	
		Connection Type	Multicast		XG5000	
		Parameter	T2O Data Size	36		XG5000
			O2T Data Size	20		
			Config Instance	2		
Output Connection Point(8bit)			170			
Input Connection Point(8bit)			160			
Transmission Cycle		20ms				
Time Out	RPI X 16					
Slave	Set up module parameter	IP Address	192.168.1.101	BootpServer		
		Subnet Mask	255.255.255.0			
		Gateway Address	192.168.1.1			
	Receiving data (Slave -> Master)	Device	D00100		XG5000	
		Size	36			
	Sending data (Master -> Slave)	Device	D00000		XG5000	
Size		20				

[BootpServer – Step1] Smart I/O Enet module parameter setting

Step	Item	Screen Configuration and Setting						
1-1	Execute BootpServer	<p>Check Bootp module list</p> <table border="1"> <thead> <tr> <th>MAC Address</th> <th>Request Count</th> <th>Request Time</th> </tr> </thead> <tbody> <tr> <td>00:e0:91:03:4c:02</td> <td>5</td> <td>10:28:29</td> </tr> </tbody> </table> <p>Select module to be set up</p>	MAC Address	Request Count	Request Time	00:e0:91:03:4c:02	5	10:28:29
MAC Address	Request Count	Request Time						
00:e0:91:03:4c:02	5	10:28:29						
1-2	Input parameter setting value.	<p>Target Address</p> <p>Selected MAC: 00:e0:91:03:4c:02</p> <p>IP Address: 192 . 168 . 1 . 101</p> <p>Subnet Mask: 255 . 255 . 255 . 0</p> <p>Gatewa Address: 192 . 168 . 1 . 1</p>						
1-3	Down load parameter	<p><input type="button" value="Write"/> Select Write button</p>						
1-4	Confirm completion of parameter setting	<p>Output</p> <p>New IP Assigned</p> <p>Check output window</p>						

[XG5000 - Step1] Program Creation

Menu Selection: File – New File

Step	Item	Screen Configuration and Setting
1-1	Set up program name	Project name: <input type="text" value="Enet Adapter"/>
1-2	Specify file location	File location: <input type="text" value="C:\XG5000\Enet Adapter"/>
1-3	Select PLC Series	<p>PLC Series</p> <p><input checked="" type="radio"/> XGK <input type="radio"/> XGB <input type="radio"/> XGI <input type="radio"/> XGR</p> <p>Select XGK</p>
1-4	Select CPU Kind	<p>CPU kind: <input type="text" value="XGK-CPUH"/></p> <p>Select XGK-CPUH</p>
1-5	Complete program creation	<input type="button" value="OK"/> Select OK button

[XG5000 - Step2]] Communication Method Setting

Menu Selection: Online – Connection Setting

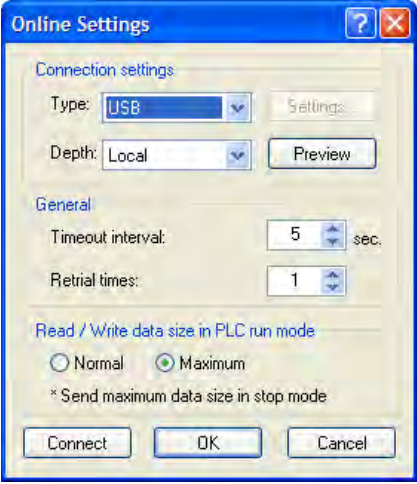
Step	Item	Screen Configuration and Setting
2-1	Set up communication method	 <p>Connection Method: USB Connection Step: Local</p>

[XG5000 - Step 3] Connection

Menu Selection: Online – Connection

[XG5000 - Step 4] I/O Information Reading

Menu Selection: Online – diagnosis - I/O Information – I/O sync

[XG5000 - Step 5] Master module TCP/IP setting

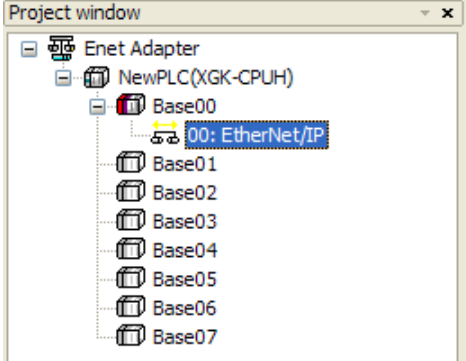
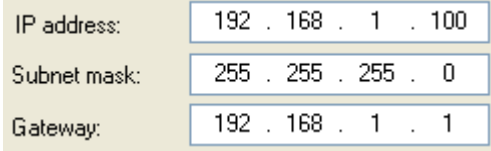
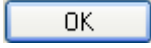
Step	Item	Screen Configuration and Setting
5-1	Set up Master module	 <p>Select Master module from basic setting tap and double click.</p>
5-2	Set up TCP/IP	 <p>IP Address: 192.168.1.100 Subnet Mask: 255.255.255.0 Gateway: 192.168.1.1 DNS Server: Setting suitable for user's environment</p>
5-3	Set up	 <p>Select OK button</p>

[XG5000 - Step 6] Basic setting parameter writing

Menu Selection: Online – Parameter Writing

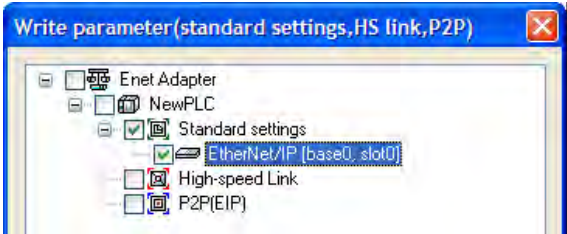
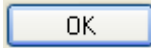
Step	Item	Screen Configuration and Setting
6-1	Select parameter writing	 <p>Select Master module</p>
6-2	Download parameter	 <p>Select OK button</p>

[XG5000 - Step 7] Individual module reset

Menu Selection: Online – Reset – Individual Module Reset

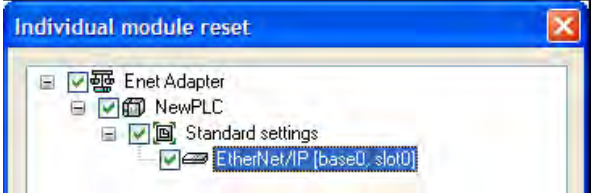
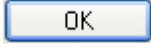
Step	Item	Screen Configuration and Setting
7-1	Select module	 <p>Select Master module</p>
7-2	Reset module	 <p>Select OK button</p>

[XG5000 - Step 8] P2P communication setting (Explicit communication)

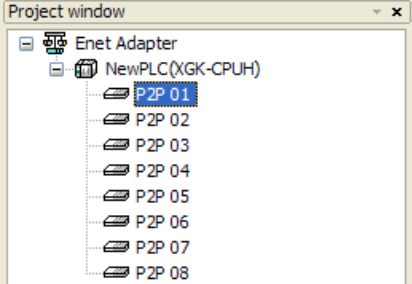
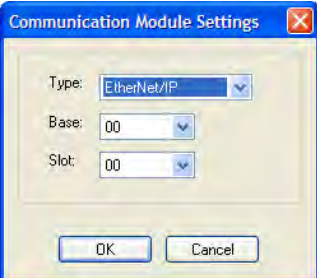
Step	Item	Screen Configuration and Setting																												
8-1	Register P2P	 <p>After selecting P2P NO.1 on P2P tap, double click it</p>																												
8-2	Set up P2P communication module	 <p>Kind: EtherNet/IP Base: 0 Slot: 0</p>																												
8-3	Set up EIP Channel	<table border="1" data-bbox="574 1141 1483 1210"> <thead> <tr> <th>Channel</th> <th>Operating Mode</th> <th>Partner Port</th> <th>Partner IP address</th> </tr> </thead> <tbody> <tr> <td>0</td> <td>Explicit Client</td> <td>44818</td> <td>192.168.1.101</td> </tr> </tbody> </table> <p>Register Explicit communication channel Partner's National IP: Register adapter module's IP address</p> <table border="1" data-bbox="574 1361 1445 1478"> <thead> <tr> <th>Ch.</th> <th>Operating Mode</th> <th>I/O type</th> <th>Connection type</th> <th>Function</th> </tr> </thead> <tbody> <tr> <td>0</td> <td>Explicit Client</td> <td></td> <td></td> <td>Generic WRITE</td> </tr> </tbody> </table> <p>Function: Generic WRITE</p> <table border="1" data-bbox="574 1582 1209 1784"> <thead> <tr> <th>Parameter items</th> <th>Contents</th> </tr> </thead> <tbody> <tr> <td>Service Code(Hex)</td> <td>10</td> </tr> <tr> <td>Class(Hex)</td> <td>4</td> </tr> <tr> <td>Instance</td> <td>180</td> </tr> <tr> <td>Attribute(Hex)</td> <td>3</td> </tr> </tbody> </table> <p>Parameter setting (UCMM setting)</p>	Channel	Operating Mode	Partner Port	Partner IP address	0	Explicit Client	44818	192.168.1.101	Ch.	Operating Mode	I/O type	Connection type	Function	0	Explicit Client			Generic WRITE	Parameter items	Contents	Service Code(Hex)	10	Class(Hex)	4	Instance	180	Attribute(Hex)	3
Channel	Operating Mode	Partner Port	Partner IP address																											
0	Explicit Client	44818	192.168.1.101																											
Ch.	Operating Mode	I/O type	Connection type	Function																										
0	Explicit Client			Generic WRITE																										
Parameter items	Contents																													
Service Code(Hex)	10																													
Class(Hex)	4																													
Instance	180																													
Attribute(Hex)	3																													

Step	Item	Screen Configuration and Setting									
8-3	Set up EIP Channel	<div style="border: 1px solid black; padding: 5px; margin-bottom: 5px;"> <p>Conditional flag</p> <p style="color: red; text-align: center;">M00000</p> </div> <p>Trigger for writing parameter: M00000</p>									
		<table border="1" style="width: 100%; border-collapse: collapse;"> <thead> <tr> <th data-bbox="574 699 731 757" rowspan="2">Data type</th> <th colspan="3" data-bbox="731 699 1199 734">tag settings</th> </tr> <tr> <th data-bbox="731 734 888 757">Local tag</th> <th data-bbox="888 734 1045 757">Remote tag</th> <th data-bbox="1045 734 1199 757">Size</th> </tr> </thead> <tbody> <tr> <td data-bbox="574 757 731 878" style="text-align: center;">1 BYTE</td> <td data-bbox="731 757 888 878" style="text-align: center;">D00200</td> <td data-bbox="888 757 1045 878"></td> <td data-bbox="1045 757 1199 878" style="text-align: center;">32</td> </tr> </tbody> </table> <p>Data Type: 1BYTE Local Tag: D00200 Size: 32 (byte)</p>	Data type	tag settings			Local tag	Remote tag	Size	1 BYTE	D00200
Data type	tag settings										
	Local tag	Remote tag	Size								
1 BYTE	D00200		32								

[XG5000 - Step 9] P2P communication setting (Implicit communication): There are two way that using dedicated or generic EDS

(1) Using dedicated EDS (XBL-BSSB EDS)

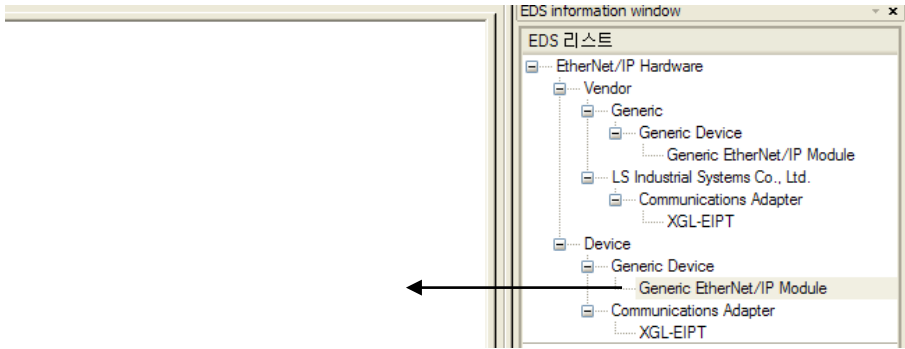
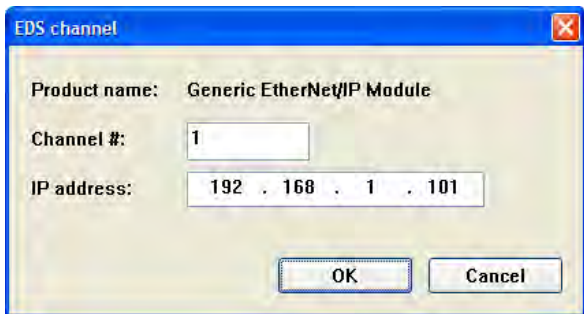
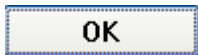
Step	Item	Screen Configuration and Setting								
9-1	Register P2P	Refer to 8-1								
9-2	Set up P2P communication module	Refer to 8-2								
9-3	Set up EIP configuration	 <p>Drag XBL-BSSB EDS to EIP configuration window</p>								
		 <p>Register channel number and adapter module's IP address</p>								
		 <p>Select OK button</p>								
9-4	Set up P2P Channel	<table border="1" data-bbox="497 1517 1384 1575"> <thead> <tr> <th>Channel</th> <th>Operating Mode</th> <th>Partner Port</th> <th>Partner IP address</th> </tr> </thead> <tbody> <tr> <td>1</td> <td>Implicit Client</td> <td>2222</td> <td>192.168.1.101</td> </tr> </tbody> </table> <p>Ensure that the channel number and partner nation's IP address are properly registered on EIP configuration window.</p>	Channel	Operating Mode	Partner Port	Partner IP address	1	Implicit Client	2222	192.168.1.101
Channel	Operating Mode	Partner Port	Partner IP address							
1	Implicit Client	2222	192.168.1.101							

Step	Item	Screen Configuration and Setting												
9-5	Set up P2P Block	<table border="1"> <thead> <tr> <th>Ch.</th> <th>Operating Mode</th> <th>I/O type</th> <th>Connection type</th> </tr> </thead> <tbody> <tr> <td>1</td> <td>Implicit Client</td> <td>2.Exclusive Owner(8bit instance)</td> <td>Multicast</td> </tr> <tr> <td></td> <td>Implicit Client</td> <td></td> <td></td> </tr> </tbody> </table> <p>After selecting communication channel, set up I/O type and connection type. 0: Exclusive Owner 1: Input Only 2: Listen Only</p>	Ch.	Operating Mode	I/O type	Connection type	1	Implicit Client	2.Exclusive Owner(8bit instance)	Multicast		Implicit Client		
		Ch.	Operating Mode	I/O type	Connection type									
		1	Implicit Client	2.Exclusive Owner(8bit instance)	Multicast									
			Implicit Client											
<table border="1"> <thead> <tr> <th>Parameter items</th> <th>Contents</th> </tr> </thead> <tbody> <tr> <td>T2D Data Size</td> <td>36</td> </tr> <tr> <td>O2T Data Size</td> <td>20</td> </tr> <tr> <td>Config Instance</td> <td>0</td> </tr> <tr> <td>Output Assembly Instance(8bit)</td> <td>170</td> </tr> <tr> <td>Input Assembly Instance(8bit)</td> <td>160</td> </tr> </tbody> </table> <p>Set up I/O data size and connection points on the parameter setting window.</p>	Parameter items	Contents	T2D Data Size	36	O2T Data Size	20	Config Instance	0	Output Assembly Instance(8bit)	170	Input Assembly Instance(8bit)	160		
Parameter items	Contents													
T2D Data Size	36													
O2T Data Size	20													
Config Instance	0													
Output Assembly Instance(8bit)	170													
Input Assembly Instance(8bit)	160													
<table border="1"> <thead> <tr> <th>Transmission period(ms)</th> <th>Time out</th> </tr> </thead> <tbody> <tr> <td>20</td> <td>2. RPI x16</td> </tr> <tr> <td>20</td> <td></td> </tr> </tbody> </table> <p>Set up data transmission cycle and time out.</p>	Transmission period(ms)	Time out	20	2. RPI x16	20									
Transmission period(ms)	Time out													
20	2. RPI x16													
20														
<table border="1"> <thead> <tr> <th colspan="3">tag settings</th> </tr> <tr> <th>Local tag</th> <th>Remote tag</th> <th>Size</th> </tr> </thead> <tbody> <tr> <td>D00100</td> <td></td> <td>36</td> </tr> <tr> <td>D00000</td> <td></td> <td>20</td> </tr> </tbody> </table> <p>Set up In/Output data local tag.</p>	tag settings			Local tag	Remote tag	Size	D00100		36	D00000		20		
tag settings														
Local tag	Remote tag	Size												
D00100		36												
D00000		20												

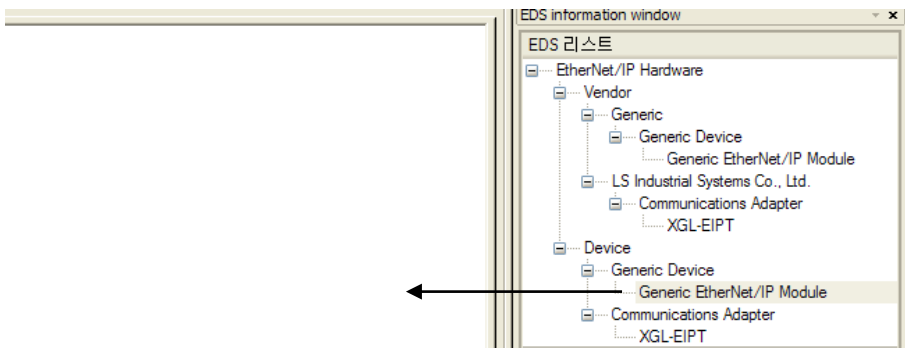
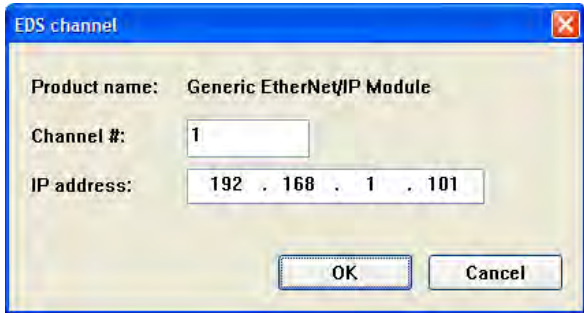
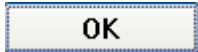

(2) Using generic EDS

Step	Item	Screen Configuration and Setting								
9-1	Register P2P	Refer to 8-1								
9-2	Set up P2P communication module	Refer to 8-2								
9-3	Set up EIP configuration	 <p>Drag Generic EtherNet/IP Module EDS to EIP configuration window</p>								
		 <p>Register channel number and adapter module's IP address</p>								
		 <p>Select OK button</p>								
9-4	Set up P2P Channel	<table border="1" data-bbox="492 1403 1381 1466"> <thead> <tr> <th>Channel</th> <th>Operating Mode</th> <th>Partner Port</th> <th>Partner IP address</th> </tr> </thead> <tbody> <tr> <td>1</td> <td>Implicit Client</td> <td>2222</td> <td>192.168.1.101</td> </tr> </tbody> </table> <p>Ensure that the channel number and partner nation's IP address are properly registered on EIP configuration window.</p>	Channel	Operating Mode	Partner Port	Partner IP address	1	Implicit Client	2222	192.168.1.101
Channel	Operating Mode	Partner Port	Partner IP address							
1	Implicit Client	2222	192.168.1.101							

Step	Item	Screen Configuration and Setting												
9-5	Set up P2P Block	<table border="1"> <thead> <tr> <th>Ch.</th> <th>Operating Mode</th> <th>I/O type</th> <th>Connection type</th> </tr> </thead> <tbody> <tr> <td>1</td> <td>Implicit Client</td> <td>2.Exclusive Owner(8bit instance)</td> <td>Multicast</td> </tr> <tr> <td></td> <td>Implicit Client</td> <td></td> <td></td> </tr> </tbody> </table> <p>After selecting communication channel, set up I/O type and connection type.</p>	Ch.	Operating Mode	I/O type	Connection type	1	Implicit Client	2.Exclusive Owner(8bit instance)	Multicast		Implicit Client		
		Ch.	Operating Mode	I/O type	Connection type									
		1	Implicit Client	2.Exclusive Owner(8bit instance)	Multicast									
			Implicit Client											
<table border="1"> <thead> <tr> <th>Parameter items</th> <th>Contents</th> </tr> </thead> <tbody> <tr> <td>T20 Data Size</td> <td>36</td> </tr> <tr> <td>O2T Data Size</td> <td>20</td> </tr> <tr> <td>Config Instance</td> <td>0</td> </tr> <tr> <td>Output Assembly Instance(8bit)</td> <td>170</td> </tr> <tr> <td>Input Assembly Instance(8bit)</td> <td>160</td> </tr> </tbody> </table> <p>Set up I/O data size and connection points on the parameter setting window.</p>	Parameter items	Contents	T20 Data Size	36	O2T Data Size	20	Config Instance	0	Output Assembly Instance(8bit)	170	Input Assembly Instance(8bit)	160		
Parameter items	Contents													
T20 Data Size	36													
O2T Data Size	20													
Config Instance	0													
Output Assembly Instance(8bit)	170													
Input Assembly Instance(8bit)	160													
<table border="1"> <thead> <tr> <th>Transmission period(ms)</th> <th>Time out</th> </tr> </thead> <tbody> <tr> <td>20</td> <td>2. RPI x16</td> </tr> <tr> <td>20</td> <td></td> </tr> </tbody> </table> <p>Set up data transmission cycle and time out.</p>	Transmission period(ms)	Time out	20	2. RPI x16	20									
Transmission period(ms)	Time out													
20	2. RPI x16													
20														
<table border="1"> <thead> <tr> <th colspan="3">tag settings</th> </tr> <tr> <th>Local tag</th> <th>Remote tag</th> <th>Size</th> </tr> </thead> <tbody> <tr> <td>D00100</td> <td></td> <td>36</td> </tr> <tr> <td>D00000</td> <td></td> <td>20</td> </tr> </tbody> </table> <p>Set up In/Output data local tag.</p>	tag settings			Local tag	Remote tag	Size	D00100		36	D00000		20		
tag settings														
Local tag	Remote tag	Size												
D00100		36												
D00000		20												

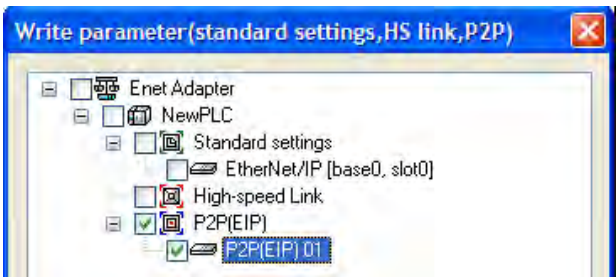

[XG5000 - Step 10]P2P setting writing

Menu Selection: Online – Parameter Writing

Step	Item	Screen Configuration and Setting
10-1	Select parameter writing	 <p>SELECT P2P NO.1</p>
10-2	Download P2P setting	 <p>Select OK button</p>

[XG5000 - Step11] Link Enable

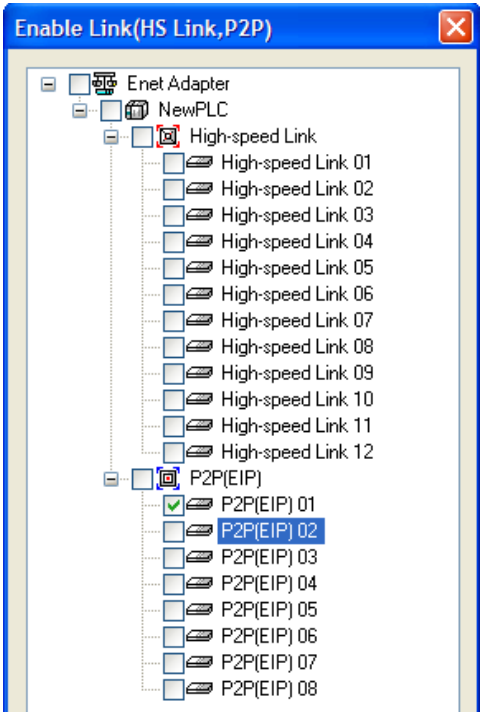
Menu Selection: Online – Link Enable

Step	Item	Screen Configuration and Setting
11-1	Set up Link Enable	 <p>Select P2P No.1</p>
11-2	Set up Link Enable	 <p>Select Write button</p>

Chapter11. RAPIEnet Communicaiton

11.1 Overview

This chapter provides information on each module's specifications, performance, and operating method for using the Smart I/O module. This chapter contains the following.

11.1 Overview

Describes the configuration, features, terminology of product

11.2 Product Specifications

Describes the communications cable specifications and standards of Smart I/O RAPIEnet

11.3 System Configuration

Describes the kinds of product available for Smart I/O series and system configuration method

11.4 Communication setting

Describes the parameter settings and how to use it setting for high speed link

11.5 Diagnostics

Describes the diagnostics provided by Smart I/O RAPIEnet

11.1.1 Characteristics of Smart I/O RAPIEnet

The RAPIEnet I/F Module carries out the communication between the PLCs in the XGT series on the basis of Ethernet communication, and provides two Ethernet ports which can be configured in line (daisy chain) and ring structure, enabling construction of network which is more flexible than conventional star-type PLC communication module. Smart I/O RAPIEnet module supports 2 electrical ports(100BASE-TX) and It is a kind of remote I/O module using XGT RAPIEnet module as a master module.

Smart I/O RAPIEnet module has following features.

- 1) Supports IEEE 802.3 Standard
- 2) Supports 100BASE-TX media and 100Mbps Full Duplex
- 3) Available to set station number (MAC Address) with hardware (0~ 63stations)
- 4) Supports ring and line (daisy chain) topology to enable construction of networks most suitable for on-site use.
Ring topology structure supports redundancy function.
- 5) Built-in switching function enables construction of ring and line topology without additional switch or hub, with reduced wiring and improved flexibility in installation.
- 6) Provides alarm function for station number conflict
- 7) Auto Cross-Over function is provided for convenient cable work.
- 8) Cable distance measuring function is provided for the use of electrical cable.
- 9) Network-based simultaneous OS upgrade.
- 10) Various diagnoses functions are provided. The status information of modules and network is provided.
- 11) Module can be set up simply with station number, without IP.

When using Smart I/O RAPIEnet, please refer to following manuals.

- 1) XG5000 User's Manual
- 2) XGK Instructions & Programming User's Manual
- 3) XGK User's Manual
- 4) XGI/XGR Instructions & Programming User's Manual
- 5) XGI/XGR User's Manual

When you configure the communication module system, please check each of the programs and modular versions. Available product specific version is as follows.

Classification	OS version
XGK CPU series	v2.0 or Above
XGI CPU series	v2.0 or Above
XGR CPU series	v1.0 or Above
XGT RAPIEnet Master	v3.0 or Above
XG5000	v4.07 or Above

11.1.2 RAPIenet Smart I/O Product Configuration

Describes the configuration of each Smart I/O RAPIenet module series

Product Name		Description	Reference
Digital I/O Module	GEL-D24C	DC24V(Rated), DC input 32 points	-
	GEL-TR4C1	DC24V, TR output 32 points (Sink 0.5A)	-
	GEL-DT4C1	DC24V, DC input 16 points/ TR output 16 points(Sink 0.5A)	-
	GEL-RY2C	DC24V(Rated), Relay output 16 points	-
Analog I/O Module	GEL-AV8C	Analog voltage input (1~5V,0~5V,0~10V,-10~10V)	-
	GEL-AC8C	Analog current input (4~20mA, 0~20mA)	-
	GEL-DV4C	Analog voltage output (1~5V,0~5V,0~10V,-10~10V)	-
	GEL-DC4C	Analog current output (4~20mA, 0~20mA)	-

11.2 Product Specification

11.2.1 Communication Specification

Communication specification of Smart I/O RAPIEnet is as below.

Category		Specification	Reference
Communication specification	Communication speed	100 Mbps	
	Transmission path method	Base Band	
	Max distance between nodes	100 m	
	Max node/ network	64	Including master
	Max protocol size	1516 bytes	
	Access to communication zone	CSMA/CD	
	Check method for frame error	CRC 32	
	Allows communication packet amount.	Max 1,500(Packet/sec)	
	Min communication period	5 msec	
	Station number setting	Set by rotary switch	Decimal
Additional functions	Emergency output of output module	Latch, Clear	Default Latch
	Communication method of input module	Cos(Change of State), Cyclic	Default Cyclic
	Heart beat setting time (msec)	200~65,500	
	Station number duplication	Displys station number duplication	
	Diagnostic parameters	Heartbeat error, Ethernet CRC error (Port1,2)	
Location of saved parameters	Parameter of Slave module	Master module	
	Parameter of High-Speed communication	CPU	

11.2.2 Communication Cable Specification

The cable standard that is applied for Smart I/O RAPIenet is as below.

1) UTP Cable

UTP cable is classified into 2 types based on the following criteria.

- (a) Shield: classified into 3 (UTP, FTP, STP)
- (b) Frequency band used: classified into 7 (Cat.1~7)

2) Type of Cables (Shield)

Classification	Details	Purpose
UTP(or U.UTP)	Unshielded cable. High speed data transmission.	Max. 200MHz Phonetic+Data+Low grade of video signal
FTP(or S.UTP)	Shielded cable core only.	Max.100MHz Electronic impediment (EMI) and electric stability considered Phonetic+Data+Low grade of video signal
STP(or S.STP)	Double-shielded cable. Shielded core and Individually shielded Pair cable	Max. 500MHz Phonetic+Data+Video signal Substitute for 75Ω coaxial cable



UTP



FTP



STP

Remarks

1. UTP : Unshielded Twisted Paired Copper Cable
2. FTP : (Overall) Foiled Twisted Paired Copper Cable
3. STP : (Overall) Shielded(and Shielded Individually Pair)Twisted Paired Copper Cable
4. Patch Cable(or Patch Cord)

Conductor composed of stranded cable instead of solid conductor may be used to increase the flexibility of UTP 4-pair cable. And surface specification and materials used is Un-coated AWG 24 (7/0203A).

In other words, the diameter of a single cable is 0.203mm, and this cable is of 1+6 structure as standardized with annealed copper cable.

3) Classification based on frequency used

Classification	Frequency used (MHz)	Transmission Speed (Mbps)	Purpose
Category 1	Phonetic Frequency	1	Phone network (2-Pair)
Category 2	4	4	Multi-Pair communication cable
Category 3	16	16	Phone network + Computer network
Category 4	20	20	1) Computer network transmission speed Up 2) Low-loss communication cable
Category 5 and Enhanced Category 5	100	100	1) Digital Phone network + Computer network 2) Low-loss, broadband cable

4) Example (CTP-LAN5) of Category 5 twisted-pair cable (UTP)

Item	Unit		Value
Conductor resistance(Max)	Ω /km		93.5
Insulation resistance(Min)	M Ω ·km		2,500
Voltage endurance	V/min		AC 500
Characteristic impedance	Ω (1~100MHz)		100 ± 15
Attenuation	dB/100m or less	10MHz	6.5
		16MHz	8.2
		20MHz	9.3
Near-end crosstalk Attenuation	dB/100m or less	10MHz	47
		16MHz	44
		20MHz	42

Remarks

Presently classified items are Category 3, 5, En-Cat.5 and Cat.6 inside and outside of the country, where Category 4 has been replaced by Category 5 and Category 7 is being under development all over the world as STP structure.

11.2.3 Digital I/O

1) Digital input(Sink/Source)

Classification		GEL-D24C	GEL-DT4C1
Input point		32Points	16Points
Rated input current		5mA	
External supply power	Voltage	DC 20.4~28.8V(Ripple rate: Less than 5%)	
	Current	Less than 300mA	Less than 294mA
ON voltage		More than DC 19V	
OFF voltage		Less than DC 6V	
Response time	OFF → ON	Less than 3ms	
	ON → OFF	Less than 3ms	
Common method		16 Points/COM	
Operation indication		LED On When input point is on	
External connection method		Terminal block connector (M3 × 6 screws)	
Insulation method		Photo-coupler insulation	
Circuit configuration			
Terminal block configuration			

2) Digital output(Sink)

Classification		GEL-TR4C1	GEL-DT4C1
Output points		32 Points	16 Points
Rated input voltage		DC 24V	
Max. load current		0.5A/point, 3A/COM	
Leakage current When Off		Less than 0.1mA	
Max. inrush current		Less than 4A 10ms	
Max. voltage drop when On		DC 1.5V(0.5A)	
External supply power	Voltage	DC 24V ± 10%(Ripple voltage less than 4Vp-p)	
	Current	Less than 270mA	Less than 294mA
Response time	OFF → ON	Less than 2ms	
	ON → OFF	Less than 2ms	
Common method		16 Points/COM	
Operation indication		LED On when input point is On	
External connection method		Terminal block connector (M3 × 6 Screws)	
Insulation method		Photo-coupler insulation	
Circuit configuration			
Terminal block configuration			

3) Relay output

Classification		Relay output module
Output point		16 Points
Rated load voltage / current		DC24V/AC220V, 2A(Cosφ=1)/point 5A/COM
Min. load voltage / current		DC 5V/1mA
Max. open/close frequency		AC 250V DC 110V, 1,200 times/hours
Response time	OFF → ON	Less than 10ms
	ON → OFF	Less than 12ms
External supply power	Voltage	DC 24V ± 10%(Ripple voltage less than 4Vp-p)
	Current	Less than 325mA
Life	Mechanical	More than 2x10 ⁷ times
	Electrical	Rated open/close voltage and current loads more than 100,000 times
		AC 200V/1.5A, AC 240V/1A(Cosφ=0.7) more than 100,000 times
		AC 200V/1A, AC 240V/0.5A(Cosφ=0.35) more than 100,000 times
Common method		8 Points/COM
Operation indication		LED On when output point is On
External connection method		Terminal block connector (M3 × 6 screws)
Circuit configuration		
Terminal block configuration		

11.2.4 Analog I/O

1) Analog input module

Classification		GEL-AV8C	GEL-AC8C
Input channel No.		8 Channels	
Analog Input type		Voltage	Current
Analog Input range		DC 1 ~ 5V DC 0 ~ 5V DC 0 ~ 10V DC -10 ~ 10V (Input resistance: more than 1 MΩ)	DC 4 ~ 20 mA DC 0 ~ 20 mA (Input resistance: 250Ω)
		Input range can be set per channel by user program or after setting I/O parameter,	
Digital Output type		16bits binary value(Data 14bits)	
Digital output range	Unsigned value	0 ~ 16,000	
	Signed value	-8,000 ~ 8,000	
	Precise value	1,000 ~ 5,000 (DC 1 ~ 5V) 0 ~ 5,000 (DC 0 ~ 5V) 0 ~ 10,000 (DC 0 ~ 10V) -10,000 ~ 10,000 (DC -10 ~ 10V)	4,000 ~ 20,000 (DC 4 ~ 20 mA) 0 ~ 20,000 (DC 0 ~ 20 mA)
	Percentile value	0 ~ 10,000	
Max. resolution		1/16,000	
Precision		0.3% (Full Scale, Ta= 0 ~ 55°C)	
Max conversion speed		10ms/8 channels	
Additional functions		Filter processing(1~99), Count average(2~64,000times), Time average(20~16,000ms)	
Insulation method		Photo-coupler insulation between output terminal and PLC power (non-insulation between channels)	
Output terminal		38 Points terminal block	
Supply power	Voltage	DC 24V ± 10%(Ripple voltage less than 4Vp-p)	
	Current	Less than 322mA	Less than 341mA
Terminal block configuration	GEL-AV8C		
	GEL-AC8C		

2) Analog Output

Classification		Specification	
Product Name		GEL-DV4C	GEL-DC4C
No. of output channel		4 Channels	
Analog output type		Voltage	Current
Analog output range		DC 1 ~ 5V DC 0 ~ 5V DC 0 ~ 10V DC -10 ~ 10V (Load resistance: more than 1 kΩ)	DC 4 ~ 20 mA DC 0 ~ 20 mA (Load resistance: less than 600Ω)
		Output range can be set per channel by user program or after setting I/O parameter,	
Digital input type		16 bits binary value(data 14 bits)	
Digital input range	Unsigned value	0 ~ 16,000	
	Signed value	-8,000 ~ 8,000	
	Precise value	1,000 ~ 5,000 (DC 1 ~ 5V) 0 ~ 5,000 (DC 0 ~ 5V) 0 ~ 10,000 (DC 0 ~ 10V) -10,000 ~ 10,000 (DC -10 ~ 10V)	4,000 ~ 20,000 (DC 4 ~ 20 mA) 0 ~ 20,000 (DC 0 ~ 20 mA)
	Percentile value	0 ~ 10,000	
Max. resolution		1/16,000	
Precision		0.3% (Full Scale, Ta= 0 ~ 55°C)	
Max. conversion speed		10ms/4 channels	
Additional functions		Setting functions of channel output status (Previous, Min, Middle, Max)	
Insulation method		Photo coupler insulation between I/O terminal and PLC power. (No insulation between channels)	
Output terminal		38 points terminal block	
Supply power	Voltage	DC 24V ± 10%(Ripple voltage less than 4Vp-p)	
	Current	Less than 315mA	Less than 481mA
Terminal Configuration	GEL-DV4C		
	GEL-DC4C		

11.2.5 Characteristic of I/O conversion

Each channel of voltage/current I/O range can be set by using module parameter. I/O conversion characteristics of A/D conversion modules are as described below.

- Unsigned Value
- Signed Value
- Precise Value
- Percentile Value

1) Input characteristic

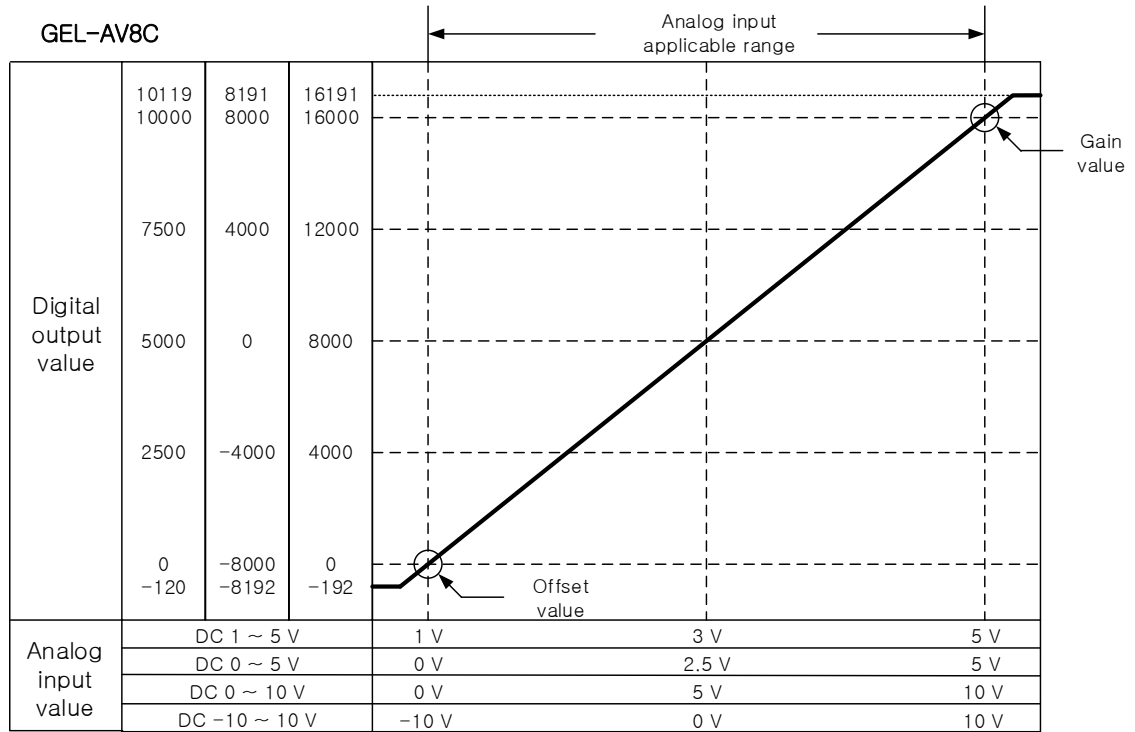

(1) DC 1 ~ 5V Input range

Digital output range	Analog input value (V)						
	0.952	1	2	3	4	5	5.047
Unsigned value (-192 ~ 16191)	-192	0	4000	8000	12000	16000	16191
Signed value (-8192 ~ 8191)	-8192	-8000	-4000	0	4000	8000	8191
Precise value (952 ~ 5047)	952	1000	2000	3000	4000	5000	5047
Percentile value (-120 ~ 10119)	-120	0	2500	5000	7500	10000	10119

(2) DC 0 ~ 5V Input range

Digital output range	Analog input voltage (V)						
	-0.06	0	1.25	2.5	3.75	5	5.059
Unsigned value (-192 ~ 16191)	-192	0	4000	8000	12000	16000	16191
Signed value (-8192 ~ 8191)	-8192	-8000	-4000	0	4000	8000	8191
Precise value (-60 ~ 5059)	-60	0	1250	2500	3750	5000	5059
Percentile value (-120 ~ 10119)	-120	0	2500	5000	7500	10000	10119

(3) DC 0 ~ 10V Input range

Digital output range	Analog input voltage (V)						
	-0.12	0	2.5	5	7.5	10	10.119
Unsigned value (-192 ~ 16191)	-192	0	4000	8000	12000	16000	16191
Signed value (-8192 ~ 8191)	-8192	-8000	-4000	0	4000	8000	8191
Precise value (-120 ~ 10119)	-120	0	2500	5000	7500	10000	10119
Percentile value (-120 ~ 10119)	-120	0	2500	5000	7500	10000	10119

(4) DC -10 ~ 10V Input range

Digital output range	Analog input voltage (V)						
	-10.24	-10	-5	0	5	10	10.239
Unsigned value (-192 ~ 16191)	-192	0	4000	8000	12000	16000	16191
Signed value (-8192 ~ 8191)	-8192	-8000	-4000	0	4000	8000	8191
Precise value (-10240 ~ 10239)	-10240	-10000	-5000	0	5000	10000	10239
Percentile value (-120 ~ 10119)	-120	0	2500	5000	7500	10000	10119

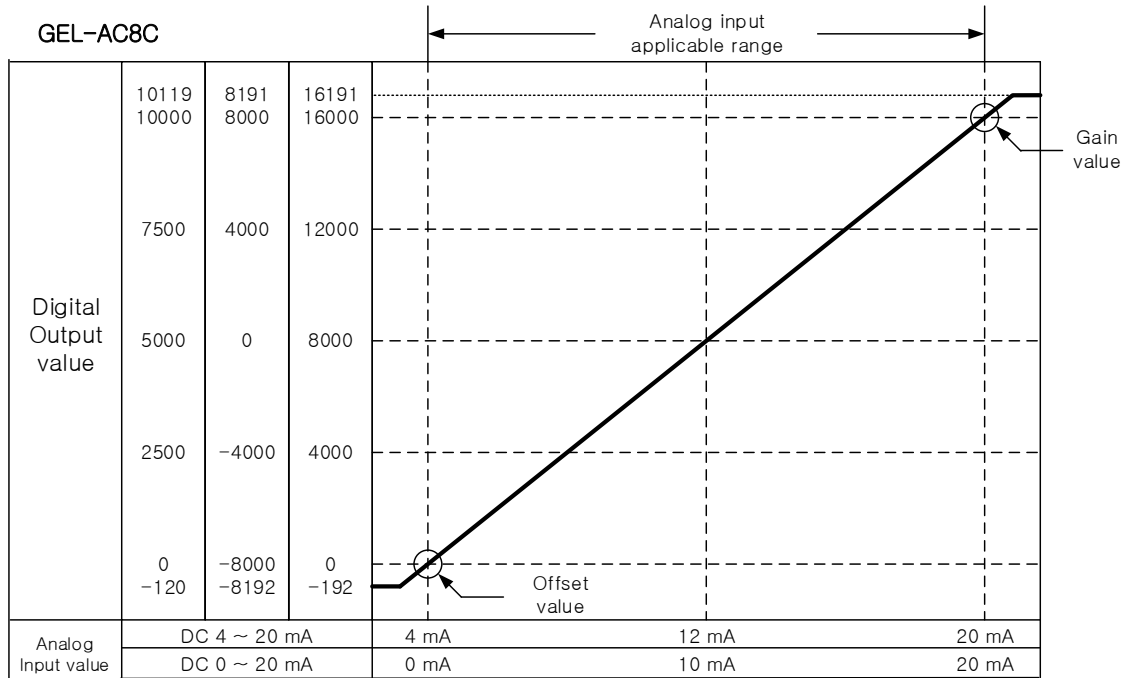

(1) DC 4 ~ 20mA Input range

Digital Output range	Analog input current (mA)						
	3.808	4	8	12	16	20	20.191
Unsigned value (-192 ~ 16191)	-192	0	4000	8000	12000	16000	16191
Signed value (-8192 ~ 8191)	-8192	-8000	-4000	0	4000	8000	8191
Precise value (3808 ~ 20191)	3808	4000	8000	12000	16000	20000	20191
Percentile value (-120 ~ 10119)	-120	0	2500	5000	7500	10000	10119

(2) DC 0 ~ 20mA Input value

Digital Output range	Analog input current (mA)						
	-0.24	0	5	10	15	20	20.239
Unsigned value (-192 ~ 16191)	-192	0	4000	8000	12000	16000	16191
Signed value (-8192 ~ 8191)	-8192	-8000	-4000	0	4000	8000	8191
Precise value (-240 ~ 20239)	-240	0	5000	10000	15000	20000	20239
Percentile value (-120 ~ 10119)	-120	0	2500	5000	7500	10000	10119

2) Output characteristic

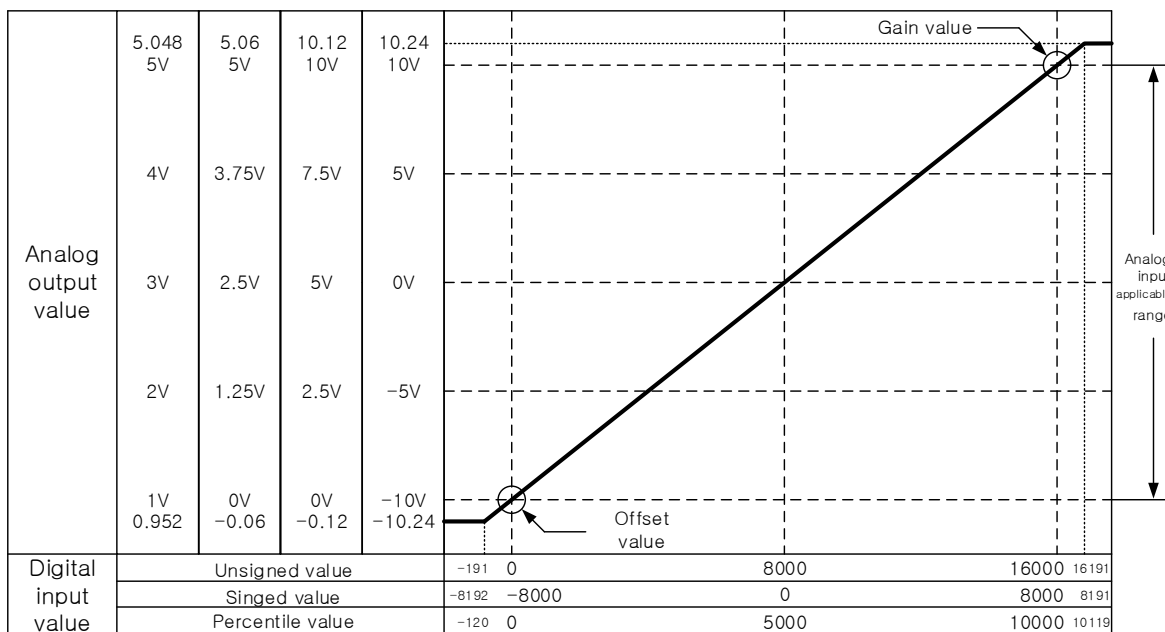

(1) DC 1 ~ 5V Output range

Digital input range	Analog output voltage (V)						
	0.952	1	2	3	4	5	5.047
Unsigned value (-192 ~ 16,191)	-192	0	4,000	8,000	12,000	16,000	16,191
Signed value (-8,192 ~ 8,191)	-8,192	-8,000	-4,000	0	4,000	8,000	8,191
Precise value (952 ~ 5,047)	952	1,000	2,000	3,000	4,000	5,000	5,047
Percentile value (-120 ~ 10,119)	-120	0	2,500	5,000	7,500	10,000	10,119

(2) DC 0 ~ 5V Output range

Digital input range	Analog output voltage (V)						
	-0.06	0	1.25	2.5	3.75	5	5.059
Unsigned value (-192 ~ 16,191)	-192	0	4,000	8,000	12,000	16,000	16,191
Signed value (-8,192 ~ 8,191)	-8,192	-8,000	-4,000	0	4,000	8,000	8,191
Precise value (-60 ~ 5,059)	-60	0	1,250	2,500	3,750	5,000	5,059
Percentile value (-120 ~ 10,119)	-120	0	2,500	5,000	7,500	10,000	10,119

(3) DC 0 ~ 10V Output range

Digital input range	Analog output voltage (V)						
	-0.12	0	2.5	5	7.5	10	10.119
Unsigned value (-192 ~ 16,191)	-192	0	4,000	8,000	12,000	16,000	16,191
Signed value (-8,192 ~ 8,191)	-8,192	-8,000	-4,000	0	4,000	8,000	8,191
Precise value (-120 ~ 10,119)	-120	0	2,500	5,000	7,500	10,000	10,119
Percentile value (-120 ~ 10,119)	-120	0	2,500	5,000	7,500	10,000	10,119

(4) DC -10 ~ 10V Output range

Digital input range	Analog output voltage (V)						
	-10.24	-10	-5	0	5	10	10.239
Unsigned value (-192 ~ 16,191)	-192	0	4,000	8,000	12,000	16,000	16,191
Signed value (-8,192 ~ 8,191)	-8,192	-8,000	-4,000	0	4,000	8,000	8,191
Precise value (-10,240 ~ 10,239)	-10,240	-10,000	-5,000	0	5,000	10,000	10,239
Percentile value (-120 ~ 10,119)	-120	0	2,500	5,000	7,500	10,000	10,119

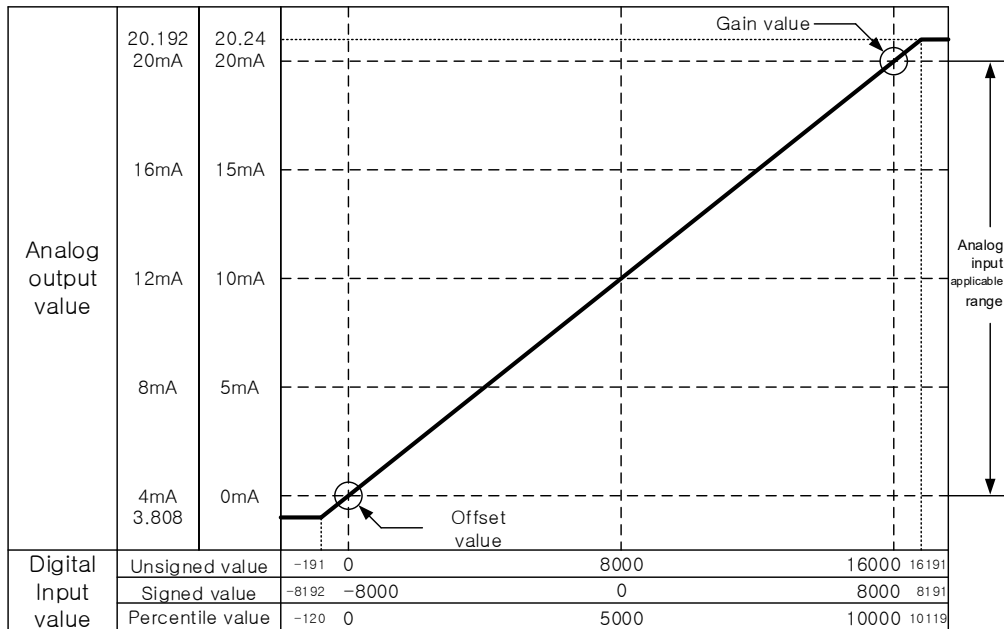

(1) DC 4 ~ 20 mA Output range

Digital input range	Analog output current (mA)						
	3.808	4	8	12	16	20	20.191
Unsigned value (-192 ~ 16,191)	-192	0	4,000	8,000	12,000	16,000	16,191
Signed value (-8,192 ~ 8,191)	-8,192	-8,000	-4,000	0	4,000	8,000	8,191
Precise value (3,808 ~ 20,191)	3,808	4,000	8,000	12,000	16,000	20,000	20,191
Percentile value (-120 ~ 10,119)	-120	0	2,500	5,000	7,500	10,000	10,119

(2) DC 0 ~ 20 mA Output range

Digital input range	Analog output current (mA)						
	-	0	5	10	15	20	20.239
Unsigned value (-192 ~ 16,191)	-	0	4,000	8,000	12,000	16,000	16,191
Signed value (-8,192 ~ 8,191)	-	-8,000	-4,000	0	4,000	8,000	8,191
Precise value (0 ~ 20,239)	-	0	5,000	10,000	15,000	20,000	20,239
Percentile value (-120 ~ 10,119)	-	0	2,500	5,000	7,500	10,000	10,119

11.2.6 Analog accuracy

1) Input accuracy

Accuracy of digital output value does not changed even if input range is changed.

Figure below shows the range of the accuracy with analog input range of 0 ~ 10 V and digital output type of unsigned value selected. Accuracy is $\pm 0.3\%$ (0~55°C).

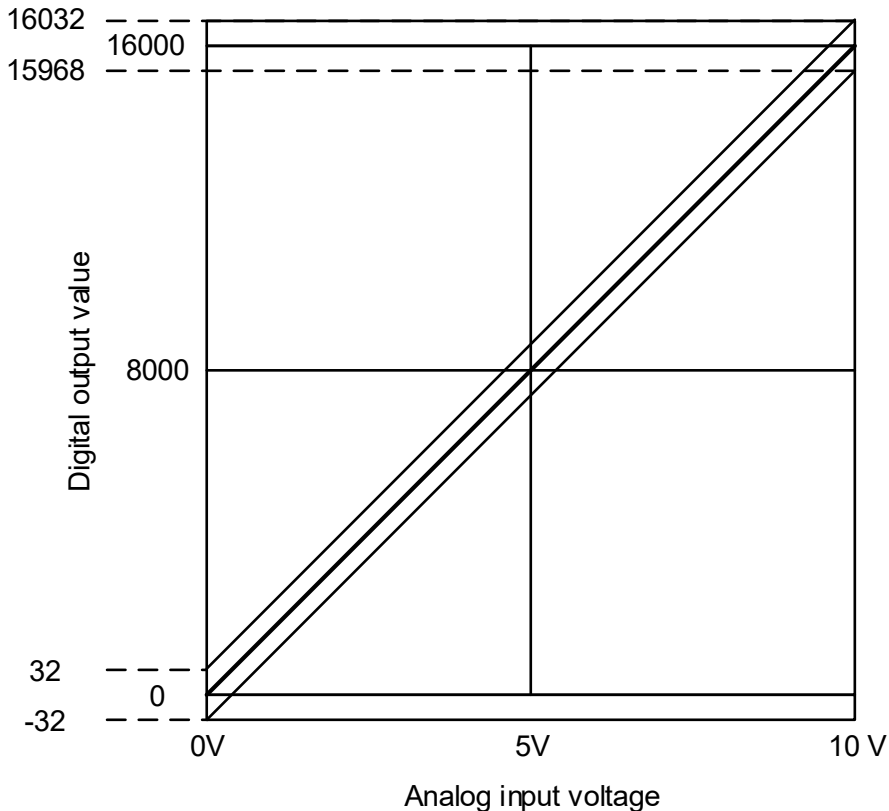

- (1) Accuracy when using 5V input = $16000 \times 0.3\% = 48$
 Therefore the range of the accuracy will become $(8000-48) \sim (8000+48) = 7952 \sim 8048$
 when using 5V input.
- (2) Accuracy when using 10V input = $16000 \times 0.3\% = 48$
 Therefore the range of the accuracy will become $(16000-48) \sim (16000+48) = 15952 \sim 16048$
 when using 10V input.

2) Output accuracy

Though the range of input is changed, the accuracy for the analog output values doesn't change. The range of accuracy is displayed at the ambient temperature of $25 \pm 5 \text{ }^\circ\text{C}$ if you select unsigned value as your range of the digital input.

The accuracy is satisfied $\pm 0.3\%$.

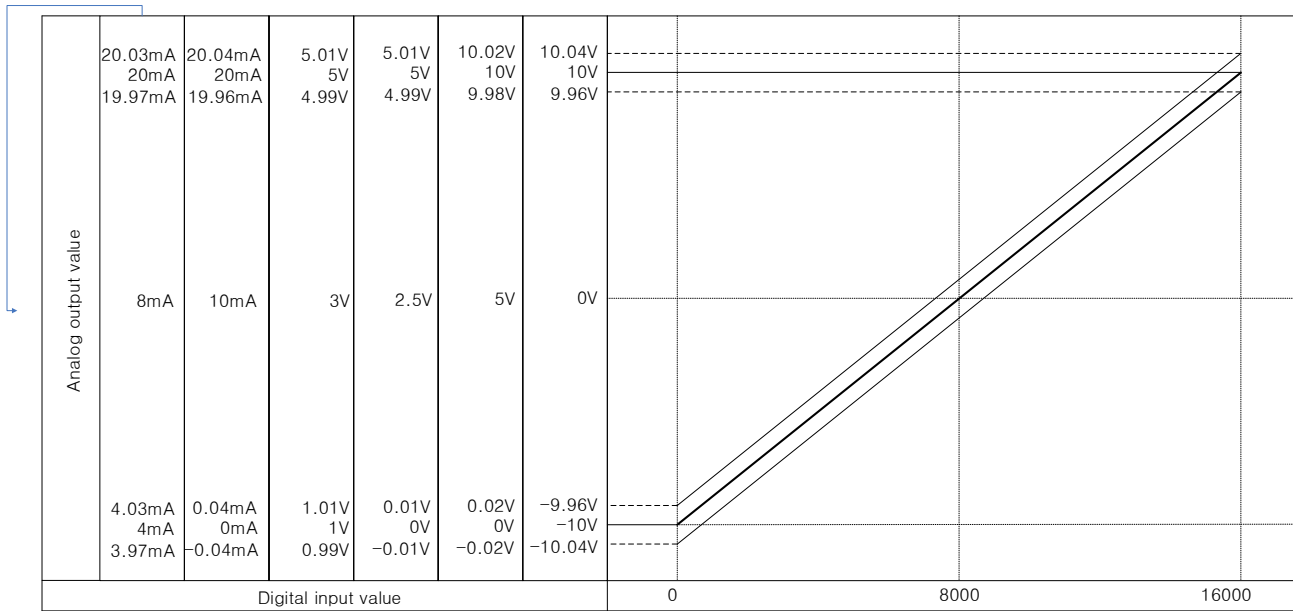

(1) Accuracy in case of -10~10V output

$$16000 \times 0.3\% = 48$$

in case of -10V output, accuracy range is $(-10V - 48 \times 1.25\text{mV}) \sim (-10V + 48 \times 1.25\text{mV}) = -10.04 \sim -9.96\text{V}$,

in case of 10V output, accuracy range is $(10V - 48 \times 1.25\text{mV}) \sim (10V + 48 \times 1.25\text{mV}) = 9.96 \sim 10.04\text{V}$

(2) Accuracy in case of 4~20 mA output

$$16000 \times 0.3\% = 48$$

in case of 4mA output, accuracy range is $(4\text{mA} - 48 \times 1\mu\text{A}) \sim (4\text{mA} + 48 \times 1\mu\text{A}) = 3.97\text{mA} \sim 4.03\text{mA}$,

in case of 20mA output, accuracy range is $(20\text{mA} - 48 \times 1\mu\text{A}) \sim (20\text{mA} + 48 \times 1\mu\text{A}) = 19.97\text{mA} \sim 20.03\text{mA}$

11.2.7 Functions of Analog Module

Here describes functions of analog module.

Function	Details
Channel Run/Stop setting	· It sets up Run/Stop of a channel that will operate an A/D conversion.
Input voltage/current range setting	· It sets up the range of an analog input. · Analog module offers input current of two range (4~20mA, 0~20mA) and voltage input of four range (1~5V, 0~5V, 0~10V, -10~10V).
Output data type setting	· It specifies digital output type. · It offers four types of output data status (Unsigned value, signed value, precise value, percentile value)
A/D input conversion method	· Sampling Process - If A/D conversion method has not been specified, the module processes sampling. · Filter process - Filters rapid changes in input value by external noise. · Averaging process - Outputs A/D converted value averaged by time, cycle, and moving.

1) Sampling Process

In popular A/D conversion process, analog input signals are collected at constant time intervals and A/D converted. The time elapsed for the analog signals converted into digital signals and saved in memory device depends upon the number of channels used.

$$(\text{Process Time}) = (\text{No. of channels used}) \times (\text{Conversion speed})$$

(Ex.) Processing time when using 8 channels : $8 \times 10\text{ms} = 80\text{ms}$

The term 'sampling' means taking analog signal values at certain time intervals.

2) Filtering Function

(1) Filtering Processing

Filter process function is used to obtain stable digital output value by filtering (delaying) noise or sudden change of input value.

Setting range: 1 ~ 99(%)

$$F[n] = (1 - \alpha) \times A[n] + \alpha \times F[n - 1]$$

$F[n]$: Present filter output value

$A[n]$: Present A/D converted value

$F[n - 1]$: Previous filter output value

α : Filter constant(0.01 ~ 0.99 : previous value added)

Setting value	Description
Non-setting	Non-filtering
1	Accept previous 1%
50	Accept previous 50%
99	Accept previous 99%

3) Average processing

(1) Time average

It accumulates input values of a selected channel and displays the average of the total sum in digital data.

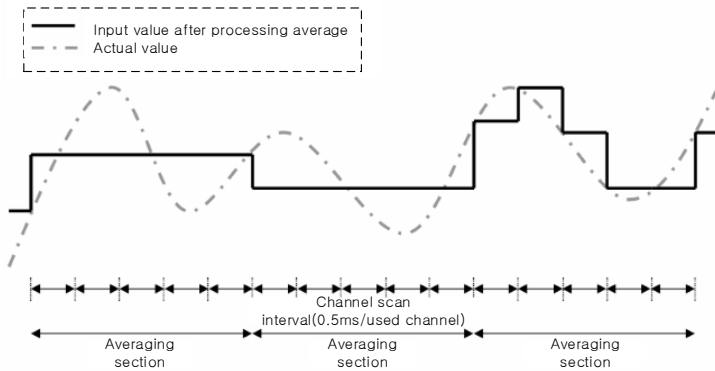

Setting range = 20 ~ 16000 [ms]

Average processing count within specified time is decided based on the number of channels used.

$$\text{Average Process count} = \frac{\text{Setting time}}{\text{No. of channel used} \times 10\text{ms}}$$

(Ex.) If the number of channels used is 8, and setting time is 16000 ms:

$$16000 \text{ ms} \div (8 \times 10 \text{ ms}) = 200 \text{ times}$$

Time average is processed after converted to average of the times inside the A/D conversion module. In this case, a remainder may be produced when setting time is divided by (number of channels used X conversion speed), which will be disregarded. Thus, the average processing frequency will be the quotient of [(setting time) ÷ (number of channels used x conversion speed)].

(Ex.) If the number of channels used is 1, and setting time is 151 ms

$$151 \text{ ms} \div (10 \text{ ms}) = 15.1\text{times} \rightarrow 15 \text{ times}$$

(2) Count average

It accumulates input values of a selected channel as many as frequency and displays the average of the total sum in digital data.

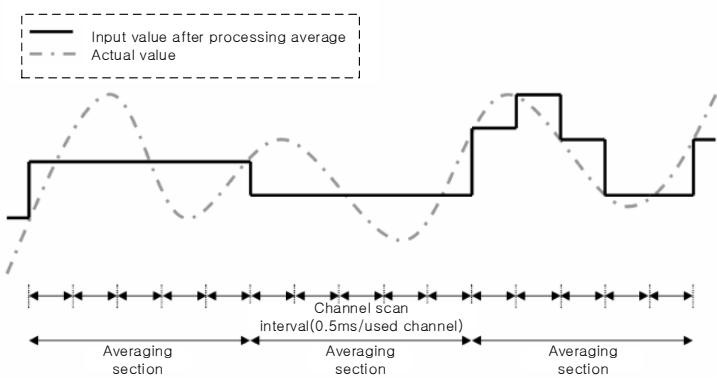

Setting range = 2 ~ 64000 [times]

The time required for average value to be saved on memory when frequency average used depend on the number of channels used.

$$\text{Process time [ms]} = \text{Setting frequency} \times \text{Number of channels used} \times \text{Conversion speed}$$

(Ex.) If the number of channels used is 3, its process time will be

$$4 \times 50 \times 10 \text{ ms} = 2000 \text{ ms}$$

Here describes functions of analog output module.

Functions	Contents
Operating channel	<ul style="list-style-type: none"> · It sets up Run/Stop of a channel that will operate an analog output. · You can save the time of whole operation by stopping unused channels.
Output range	<ul style="list-style-type: none"> · It sets up the range of an analog output. · Analog output voltage module offers four types of output range(DC 1~5V, DC 0~5V, DC 0~10V, DC -10~10V), Analog output current module offers two types of output range (DC 4~20mA, DC 0~20mA)
Input data range	<ul style="list-style-type: none"> · It sets up the range of a digital input. · It offers four types of a digital input. (Unsigned value, signed value, precise value, percentile value)
Channel output status	<ul style="list-style-type: none"> · It sets output status when communication cable is disconnected. · It offers four types of output status.(Previous, Min, Middle, Max value)

4) Channel Output State Setting Function

It sets output against PLC stop and abnormal state.

(1) Functions

It is used to output an already set value when PLC system switches RUN to Stop.

(2) Types

You can select one among previous, min, middle and max value.

- a) Previous value: Keeps last normal output value.
- b) Min. value: Outputs minimum value of the each output range.
- c) Middle value: Outputs middle value of the each output range.
- d) Max. value: Outputs max. value of the each output range..

(3) Example

When output is 10mA and range of output channel is 4~20mA, if system switches Run to Stop, it outputs as follows according to output state setting.

- (a) Previous value: keeps previous output, 10mA
- (b) Min. value: outputs min. value of corresponding range, 4mA.
- (c) Middle value: outputs middle value of corresponding range, 12mA
- (d) Max. value: outputs max. value of corresponding range, 20mA.

11.3 System Configuration

11.3.1 Names of Each Part

Describes the shape and role of Smart I/O RAPIEnet

1) Digital stand-alone type

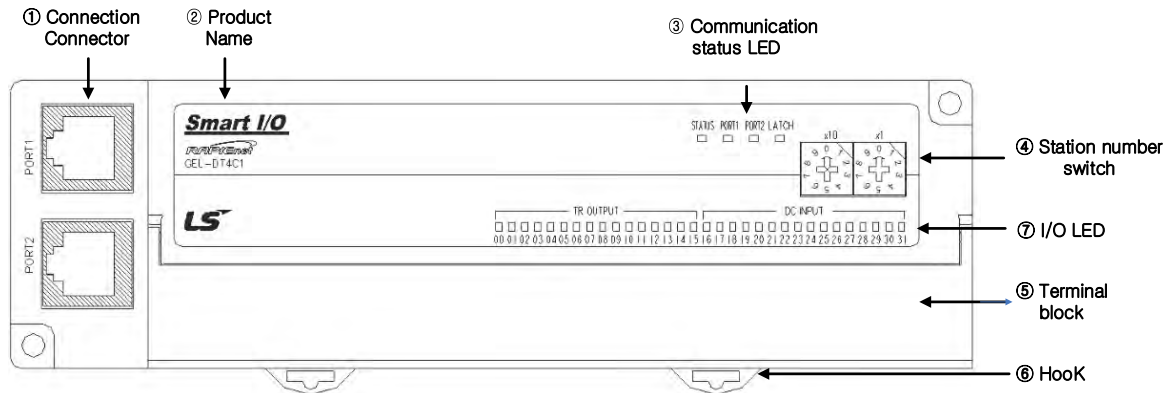

2) Analog stand-alone type

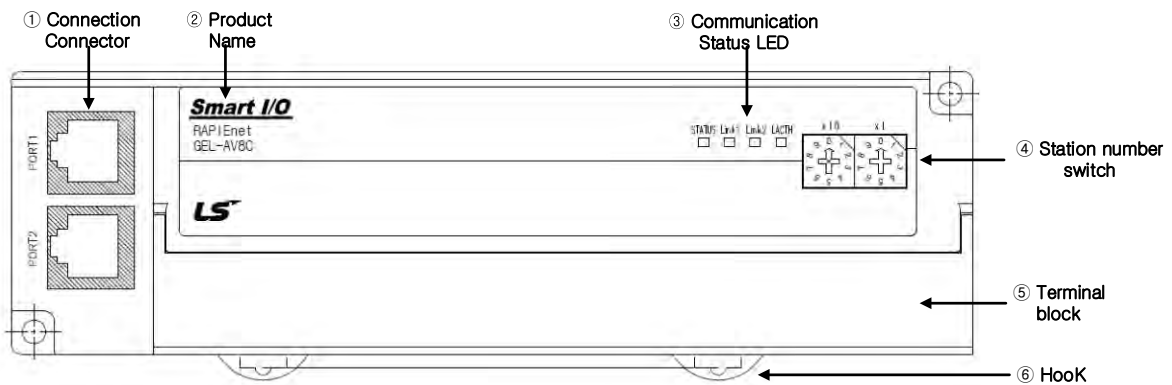

Describes the Name and Purpose of each Smart I/O RAPIEnet

No.	Name	Purpose
1	Connection connector	Connect Master/remote module for communication -RJ-45 Connector 2ports
2	Smart I/O type name indication	GEL- D24C : DC input 32 points GEL- TR4C1 : TR output 32 points GEL- RY2C : Relay output 16 points GEL- DT4C1 : DC input 16points/ TR output 16points GEL-AC8C/AV8C : 8 channel analog current/voltage input GEL-DC4C/DV4C : 4channel analog current/voltage output
3	Communication status indication LED	Communication status (See LED operating characteristics)

No.	Name	Purpose
4	Switch for setting station number	1. Switch for setting own node station No. from 0 to 63 • X10 : 10 digit indication • X1 : 1digit indication 2. When station number is set by 90 or above, this module will operate as a special purpose. 1) 90, 91: O/S download mode ^{*Note1)} 2) 92~94: Self-Test mode 3) 96~99: Communication status LED check mode
5	Terminal block	Terminal block array for I/O wiring * refer to the Ch.3.3
6	HOOK for DIN rail	HOOK for DIN rail
7	I/O LED	Indicates the points status of I/O terminal block

Note1) In case of O/S download mode, the user is prohibited any setting..

The colors and roles of each LED are as follows.



Classification	Color	Operation Status			Reference
		On	Normal	Normal status	
STATUS	Green	On	Normal	Normal status	
		Flicker	Normal	Self-diagnosis normal service	Station number Switch: 92
	Red	On	Error	Heartbeat Error occurred, Network disconnected	
			Error	Self-diagnosis service error	Station number Switch: 92
		Flicker	Normal	Boot mode operation	
			Error	Duplicated station address	See Remark
PORT1	Green	On	Normal	Network link is successfully configured through port 1	
		Off	Stand-by	Network disconnected	
	Red	Flicker	Normal	Communication on Port1	
PORT2	Green	On	Normal	Network link is successfully configured through port 2	
		Off	Stand-by	Network disconnected	
	Red	Flicker	Normal	Communication on Port2	
LATCH ^{*Note2)}	Green	On	Latch	When emergency ^{*Note1)} Hold output state	
		Off	Clear	When emergency Clear output data	

*Note1) When emergency status: The data of Master module is not received within given time due to network problems.

*Note2) LATCH: Latch functions are shown only for output module (GEL-TR4C1/DT4C1/RX2C).

Remarks

When duplicated Station address is occurred, please refer to the following operating conditions.

1. In case that the power of Smart I/O RAPIEnet modules turns on at the same time in duplicated network configuration.
 - STATUS LED: Red Flicker
 - Data Output:

Classification	Data status	Reference
Input module	No data transmission	
Output module	No data output	

2. When station address of added Smart I/O is duplicated with existing module.

- 1) When the heartbeat of master module is set (Normally operated module)

- (1) STATUS LED

Classification	STATUS LED(Red)	Reference
STATUS	Green	Off
	Red	On

When duplicated station address is internally monitored, LED status is changed from flicker to ON.

- (2) Input/ Output Data

Classification	Data status	Reference
Input module	No data transmission	
Output module	Emergency output data output	Clear default value

- 2) When the heartbeat of master module is set (Newly added module in a network)

- (1) STATUS LED: Red Flicker

- (2) Data Output:

Classification	Data status	Reference
Input module	No data transmission	
Output module	No data output	

- 3) When the heartbeat of master module is not set (Normally operated module)

- (1) STATUS LED: Red Flicker

- (2) Data Output:

Classification	Data status	Reference
Input module	No data transmission	
Output module	Maintain previous output value	

- 4) When the heartbeat of master module is set (Newly added module in a network)

- (1) STATUS LED: Red Flicker

- (2) Data Output:

Classification	Data status	Reference
Input module	No data transmission	
Output module	No data output	

11.3.2 System configuration

Smart I/O RAPIenet system configuration is divided into Ring, Line.

1) Ring System

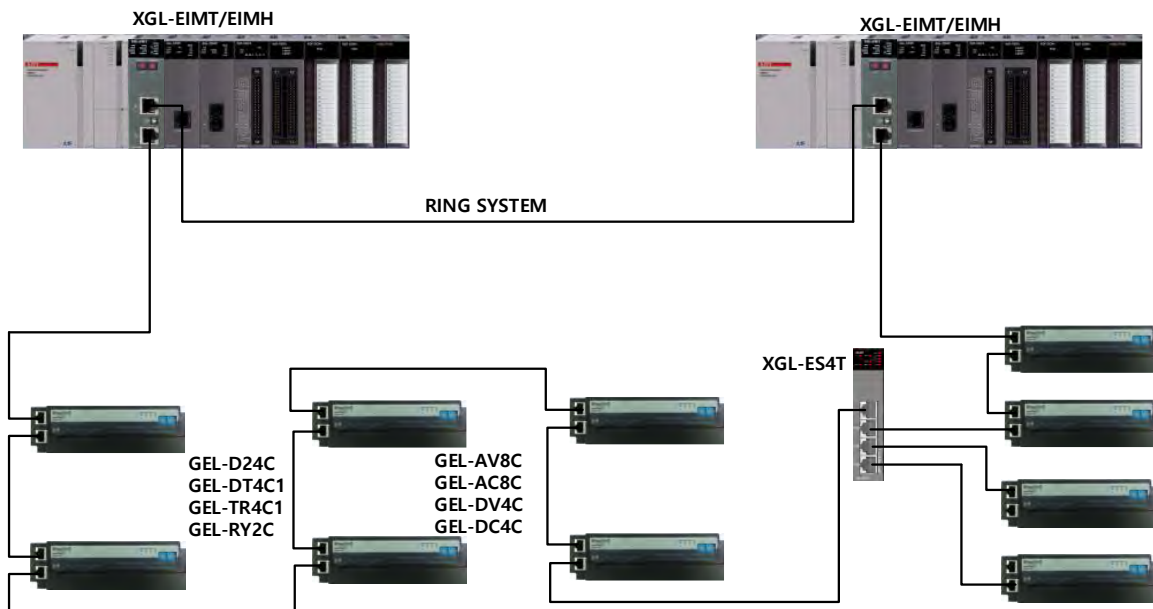

2) Line System

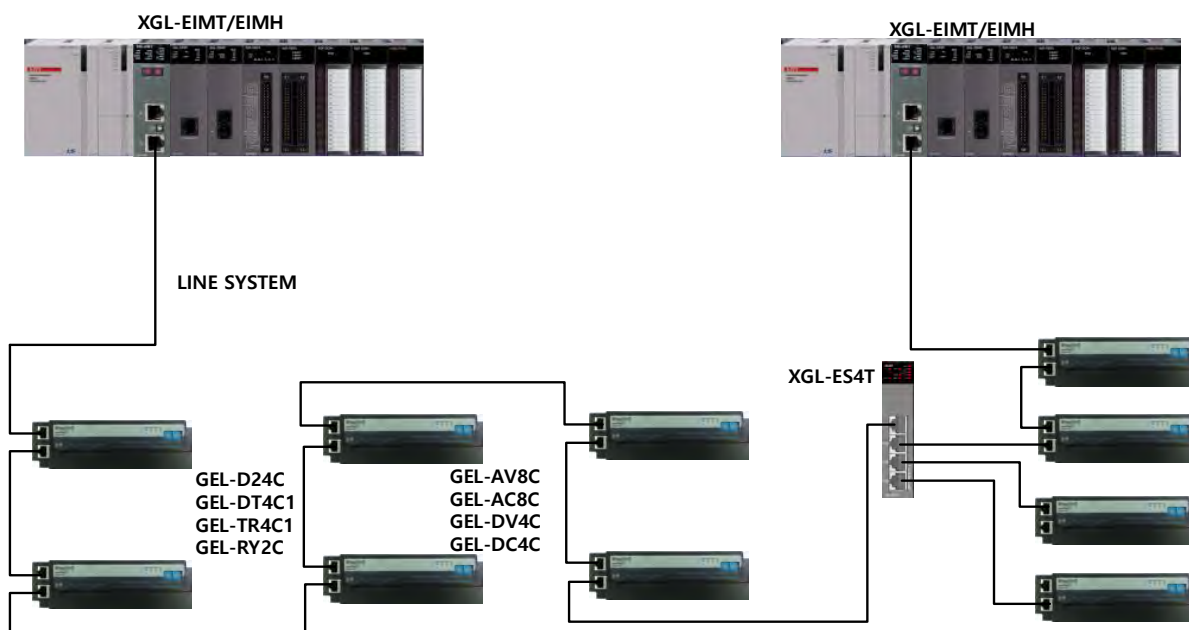

11.4 Communication Settings

Smart I/O RAPIEnet can be used after setting high-speed links and parameters of Smart I/O using XG5000, and the whole setting procedures are as follows.

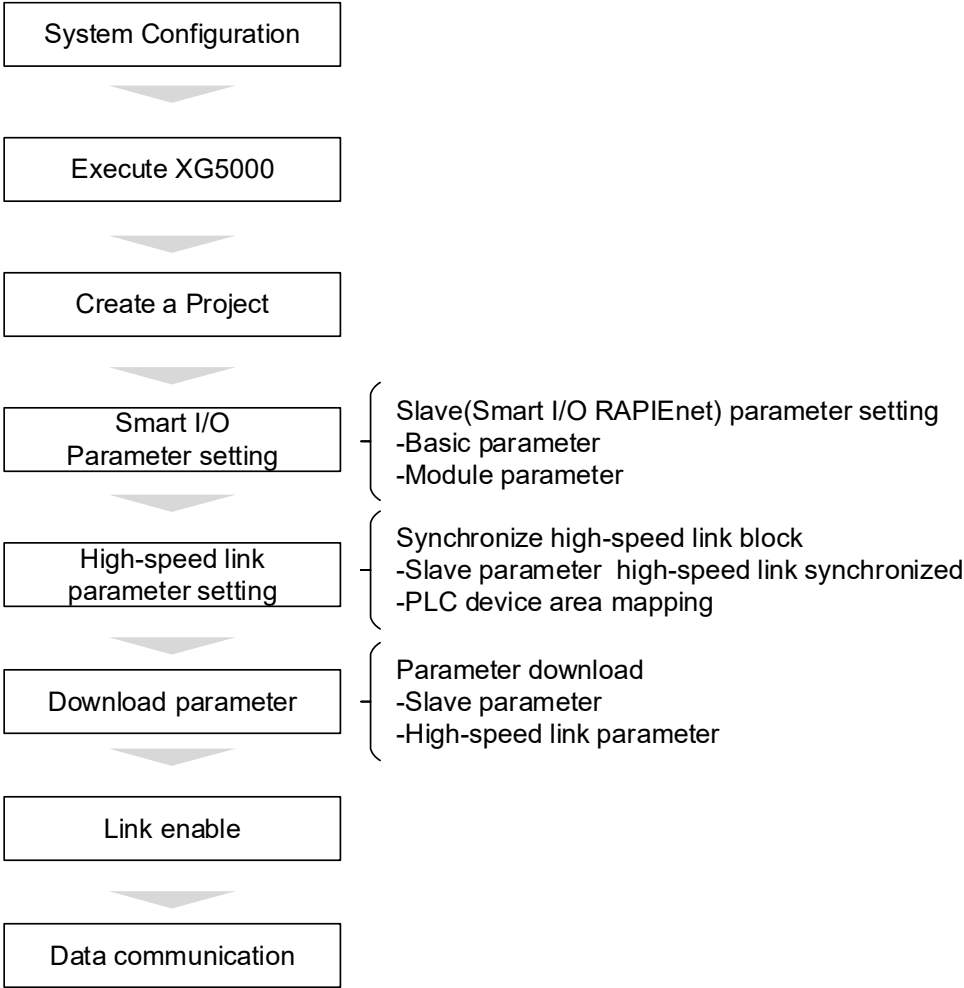

11.4.1 Smart I/O RAPIenet Parameter Settings

For Smart I/O RAPIenet, basic parameters and module parameters can be set by using XG5000. Methods on how to set the parameters are divided into a method in On-line and a method through Off-Line, and can be set via slave configuration menu.

1) Slave configuration window creation

Slave configuration window can be created by registering RAPIenet in I/O parameter after creating the project through the project creation of XG5000, and setting order and functions per item are as follows.

Project creation

a) Run XG5000 and select [Project]→[New Project]. Select CPU series and type by referring to the module information of the system configuration.

(1)

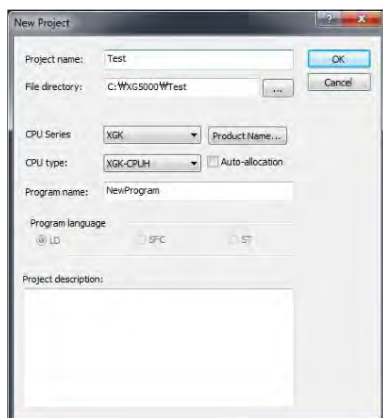

b) Click OK after entering the basic information necessary to create the project.

(2)

Registration of master module

Methods on how to register a master module are divided into a method in online mode in which XG5000 is connected to CPU and an off-line setting method.

a) Setting in the online mode

- (a) Connect to PLC via [Online]→[Connect] of XG5000 menu.
- (b) Change to [Online]→[Mode]→[Stop] for I/O parameter synchronization.
- (c) Select [Online]→[Diagnosis]→[I/O information], and I/O information window is shown below.

Click I/O synchronization and proceed with the synchronization of the module installed between CPU and base.

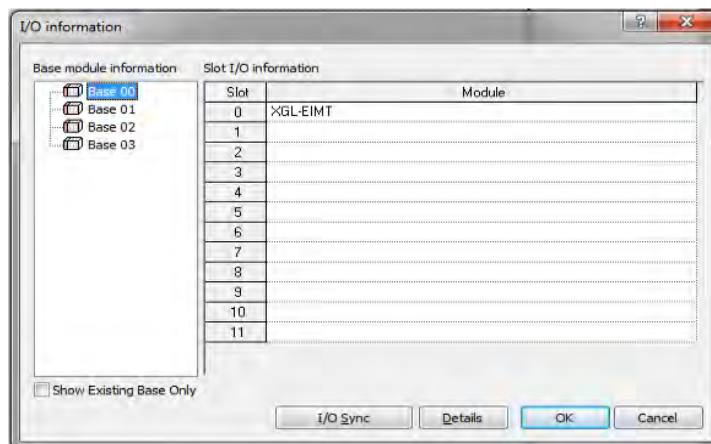

- (d) Click I/O synchronization, and the message that indicates I/O parameters are overwritten to the PLC is generated. Click [OK].

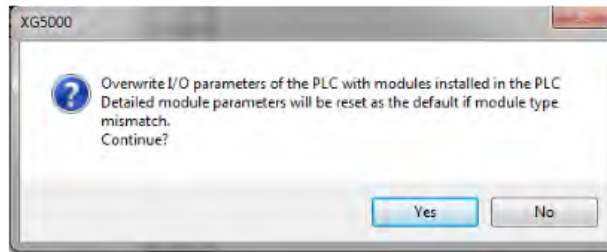

- (e) Check if XGL-EIMT module is registered in the project window [Network Configuration][Basic Network].

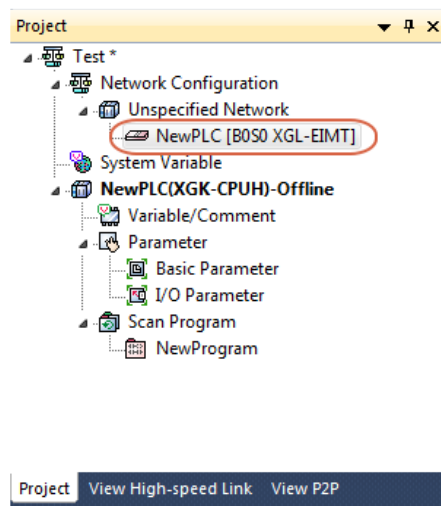

- (f) Select [Add item] → [Add slave] menu by clicking the right mouse button after selecting XGL-EIMT registered as new on the network configuration screen. Or, select [Project] → [Add item] → [Add slave] of XG5000 menu to perform the same function.

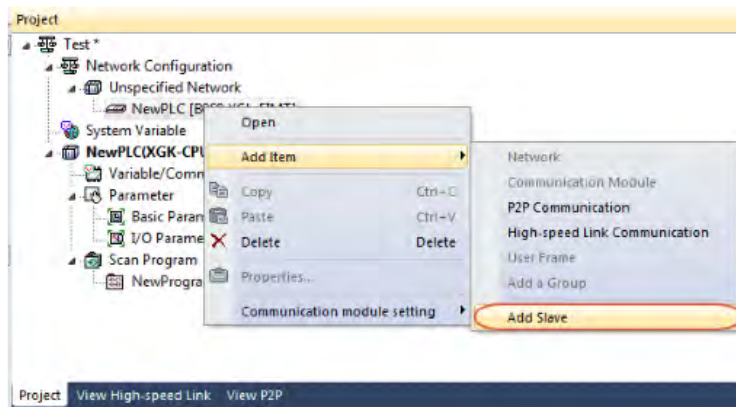

(g) Check if the slave configuration window is created.

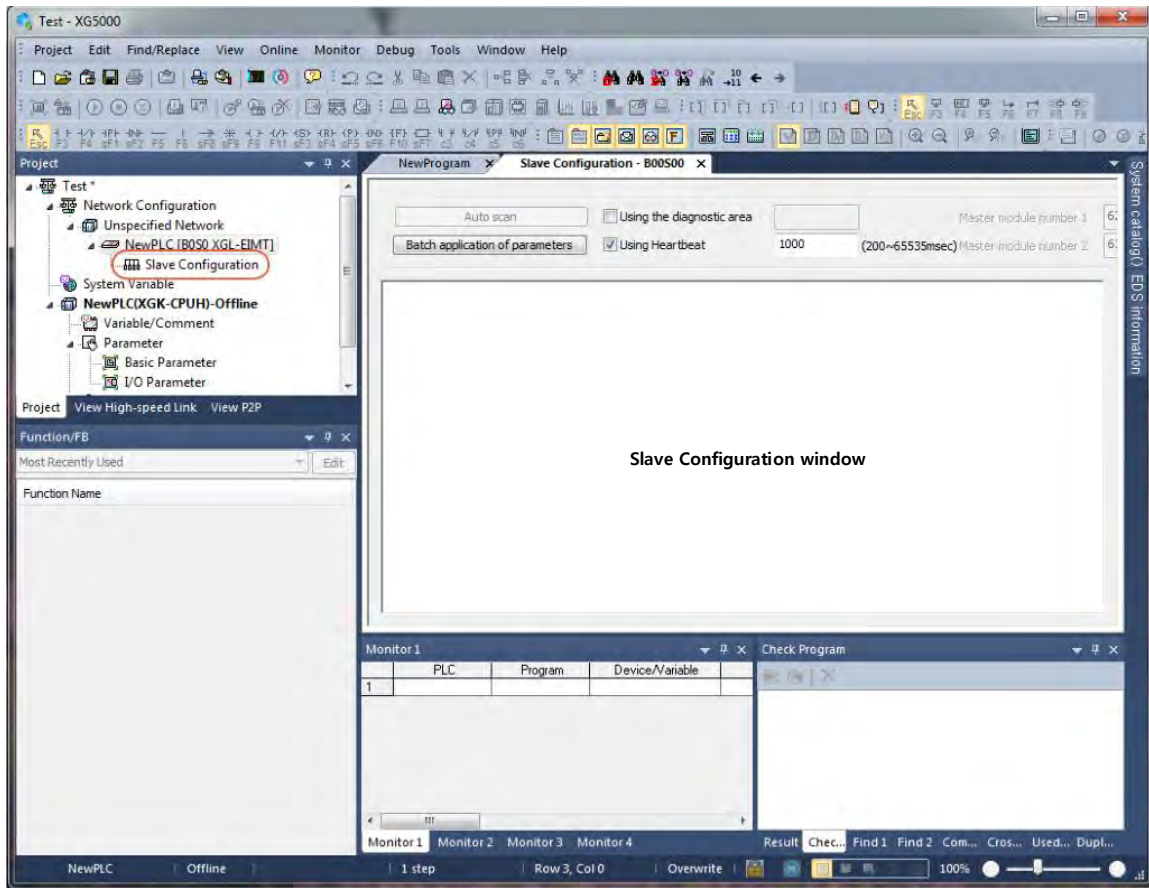

b) Setting in the offline mode

(a) Double click the I/O parameter of the project window and then select XGL-EIMT as the application module to the slot number 0.

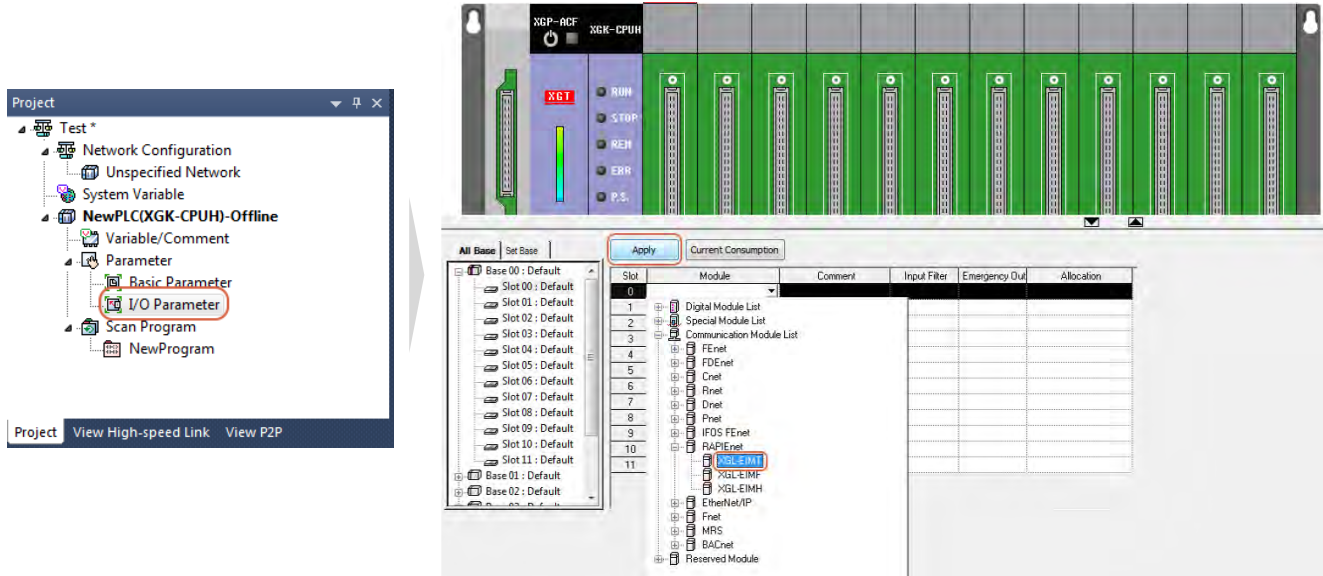

(b) Click the application, and the message that indicates the module set in I/O parameter is registered is generated. Click [Yes].

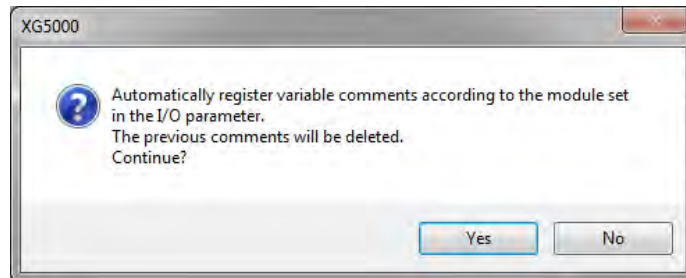

(c) Check if XGL-EIMT module is registered in the project window [Network Configuration][Basic Network].

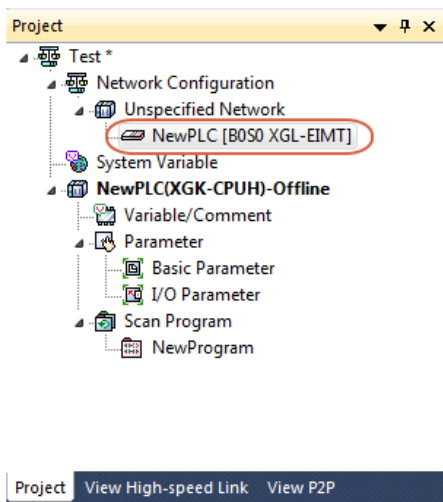

(d) Select [Add item] → [Add slave] menu by clicking on the right mouse button after selecting XGL-EIMT registered as new on the network configuration screen. Or, select [Project] → [Add item] → [Add slave] of XG5000 menu to perform the same function.

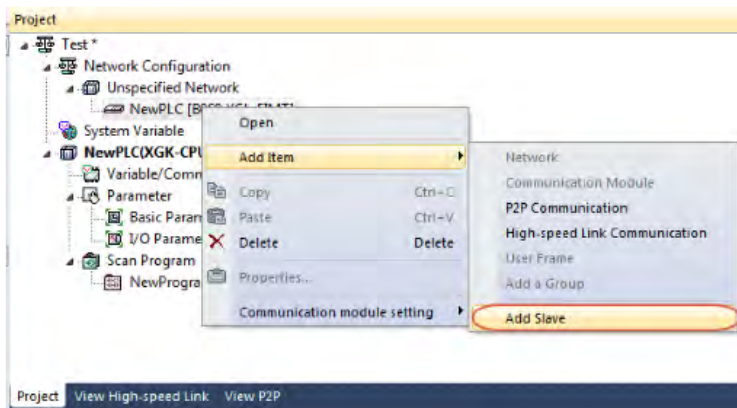

(e) Check if the slave configuration window is created.

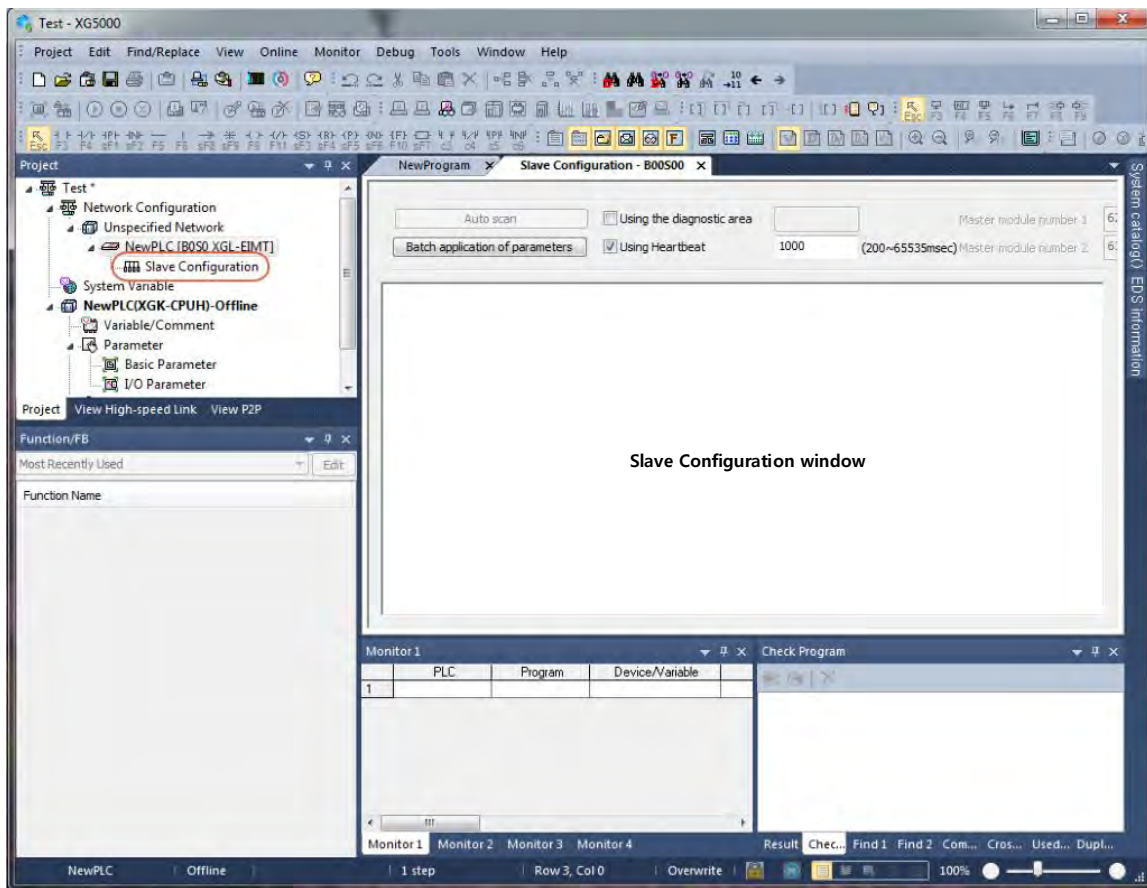

2) Slave configuration menu

Smart I/O RAPIEnet module is a slave module, and thus it requires parameter settings by each slave in order to communicate with a master module. The configuration window for slave setting^{*notice1)} is as follows.

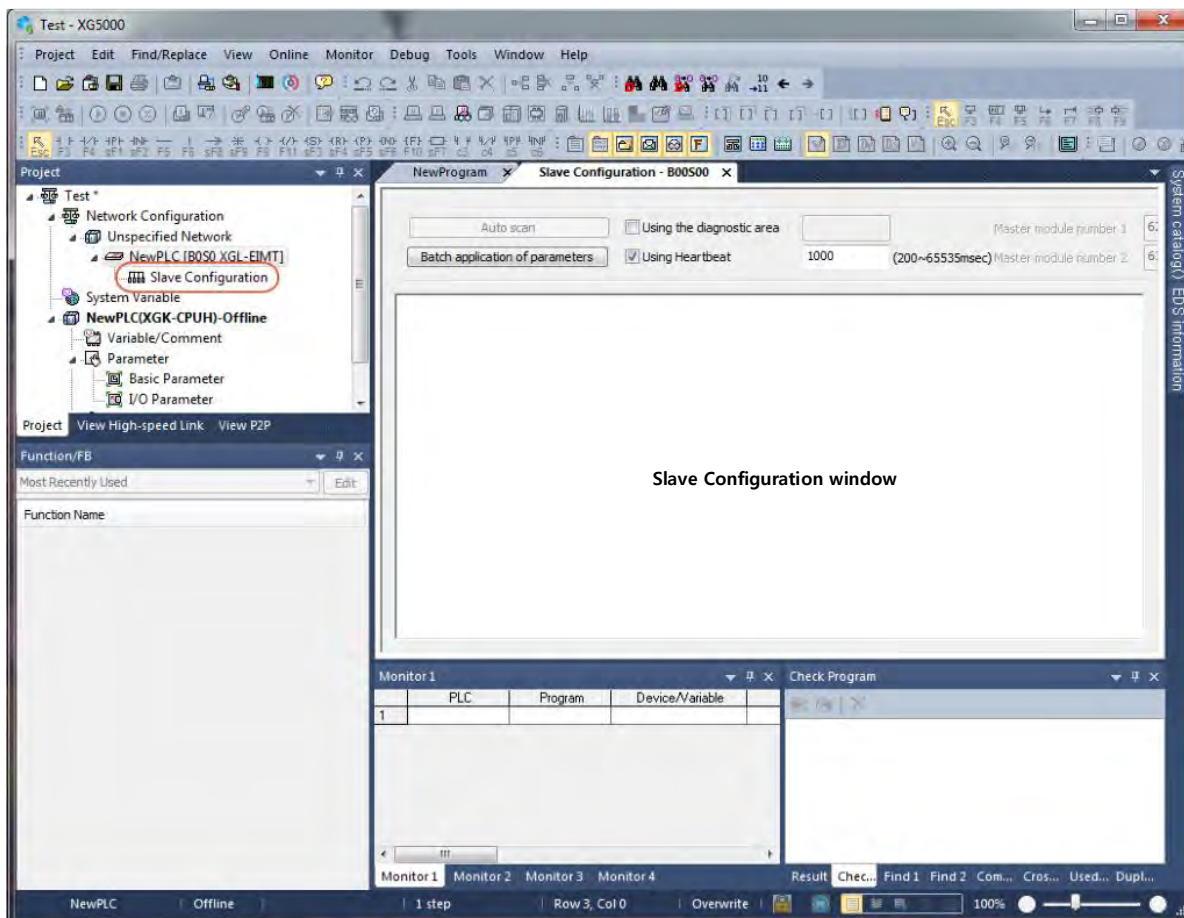

Remarks

Notice1) Slave configuration window is created by clicking [XG5000→Project→Add item→Add slave] after registering RAPIEnet master module(XGL-EIMT)in the basic network.

System catalog

It includes the information about module parameter and basic parameter on the Smart I/O RAPIEnet module. Double click the Smart I/O to be used or drag-in to the slave configuration window, and the parameter setting window for the module is created.

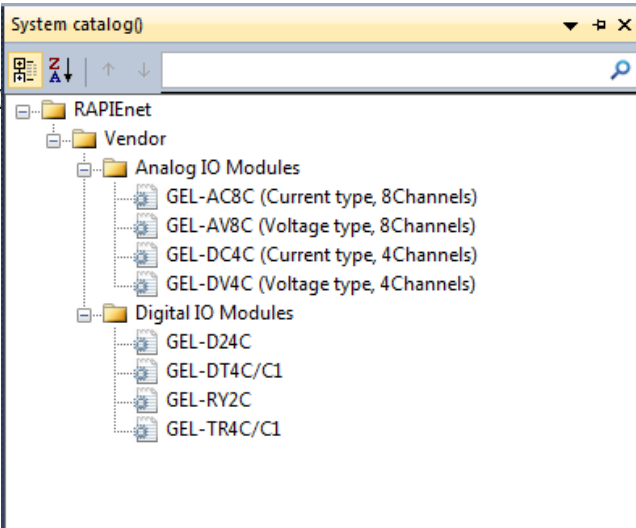

<System catalog>

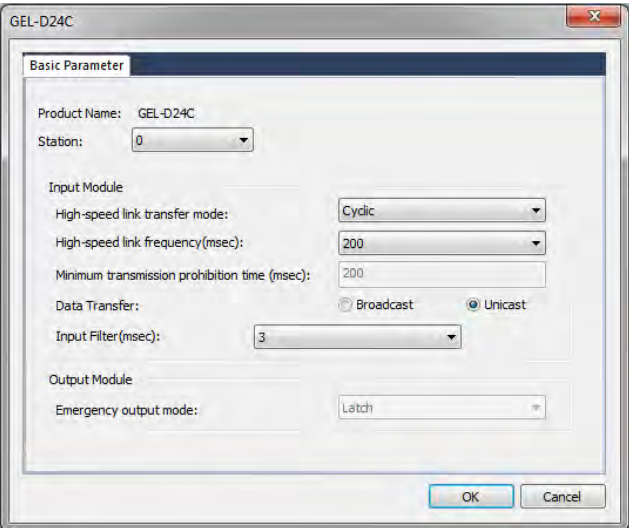

<Example of parameter setting window>

Auto Scan

It is an item which is enabled only when XG5000 is connected to the PLC online. Smart I/O connected to the RAPIEnet master module can be added by clicking Auto Scan. Click Add Slave of Auto Scan, and the slave list available on the network is created.

(2)

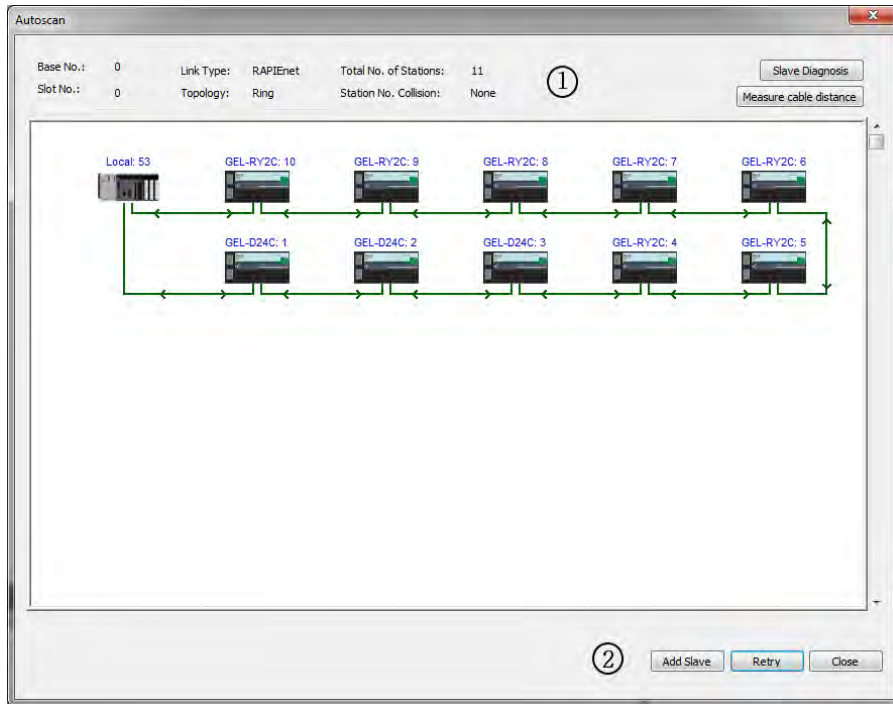

<Example of Auto Scan>

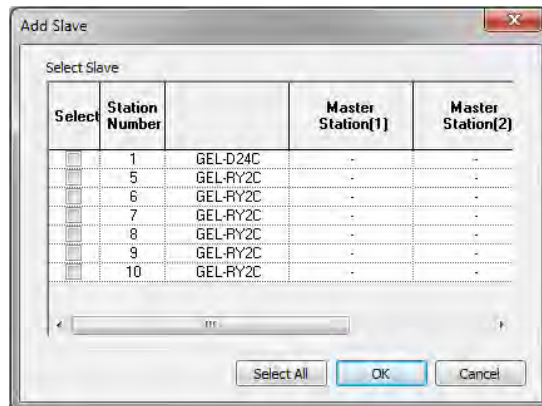

<Add slaves>

Division	Name	Meaning
1	Basic Information	It refers to the network configuration information of the master station No. (Local).
2	Add Slave	It is a function to select the module intended to controlled among Smart I/O modules that exist within the network in the master station No.(Local). *Notice1)

Remarks

Notice1) When you click the Slave Add button, only the Smart I/O in which parameters are not set can be added. If the slave you want to select from [Add Slave] window is controlled by another master module, the slave cannot be selected.

Batch application of parameters

It is a function used for batch application depending on the module type. It is convenient to set parameters since batch application of parameters for each module is possible in the system constituted by the same kind of Smart I/O.

(3)

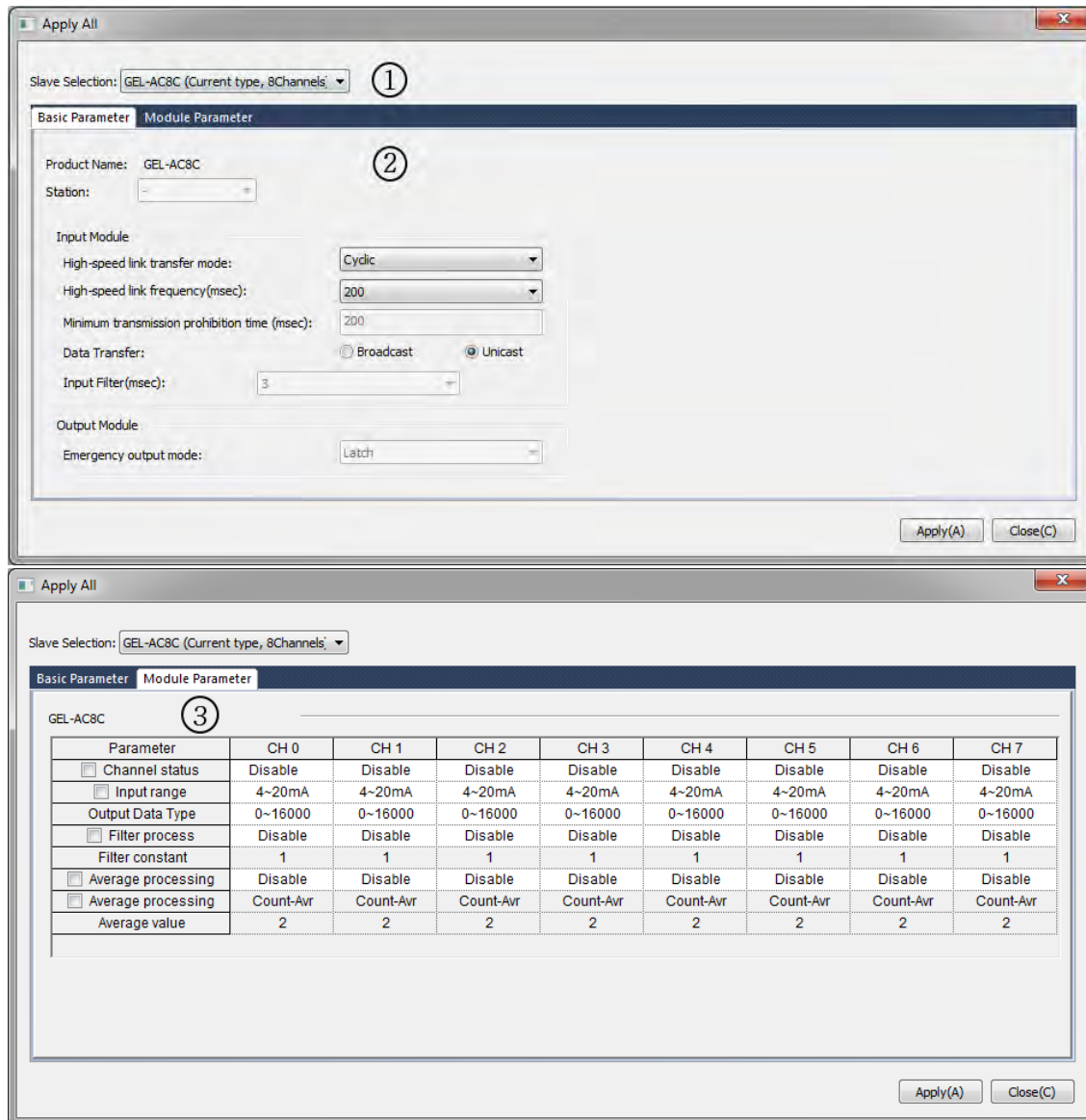

Functions for each menu are as follows.

Division	Name	Meaning
1	Slave selection	It refers to the module in which the parameter batch application function is to be applied.
2	Basic parameter	It means the basic parameter of the module.
3	Module parameter	It means the module parameter. The module parameter is enabled only if the analog I/O module is selected.
4	Apply	The set parameter is applied.

Diagnostic area use

Diagnostic area use function is to transmit the diagnostic information provided by the slave module to the PLC device area. Check the diagnostic area use and enter the starting address of the PLC device in which the diagnostic information is stored, and the diagnostic area of 1 word per slave is automatically allocated to the high-speed link block.

(Diagnostic information area is updated every 500ms.)

(4)

Heartbeat use

It is a function to check if network elimination between Smart I/O and RAPIEnet master occurs. The presence within the network can be confirmed by checking heartbeat signals at set time intervals. The heartbeat period can be set up to 200~65500msec, and the heart beat error information for each Smart I/O can be provided if the diagnostic area use is checked.

(5)

Master module station No

It is a function that is enabled when Smart I/O is used in the XGR CPU and refers to the station number of the master module mounted on the side of standby and master of the XGR CPU.

(6)

<Slave modules common parameter>

3) Basic parameter setting items

Basic parameter means the basic parameter settings for the communication between Smart I/O module and master, and the setting method is to double click or drag in the slave module to the slave module from the catalog menu of the slave configuration window. Basic parameter are largely divided into the station No. information, input module and output module setting items, and the setting items are automatically enabled, depending on the module type.

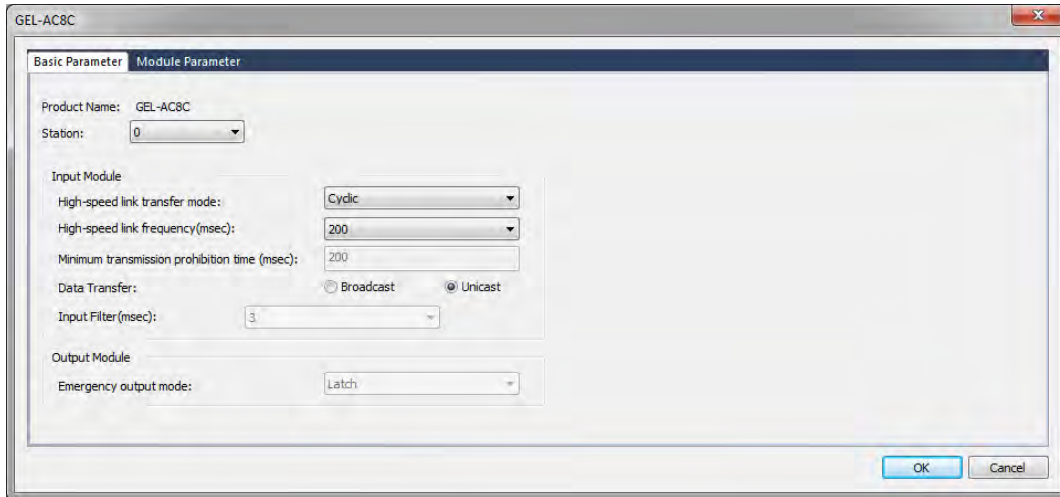

<Example of basic parameter (GEL-AC8C)>

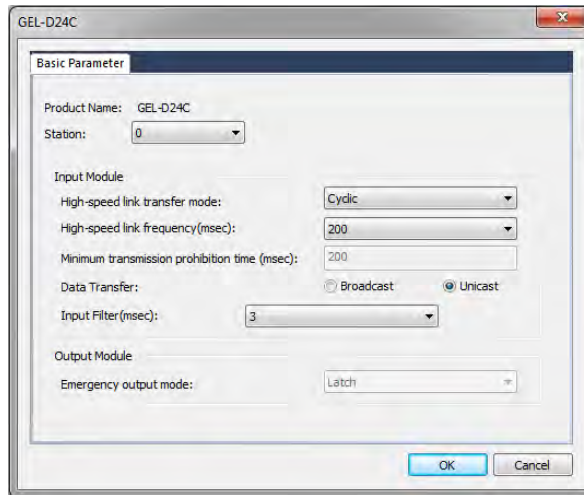

< Example of basic parameter (GEL-D24C)>

- (1)
- (2)
- (3)

Product name

It displays the product name of the Smart I/O module.

Station No.

It is the setting menu for the station No. of the Smart I/O, and the setting range is from 0 to 63.

High-speed link transmission mode

It is an item that is enabled only when the module of input type is selected and can be set to Cyclic and CoS.

Name	Meaning	Remarks
Cyclic	It is used if the data is transmitted periodically.	Default value
CoS	It is used if the data is transmitted only when the input status changes. In case the change of data is slow, the network load can be reduced by applying the CoS method.	

High-speed link transmission cycle

It is an item that is enabled only if the high-speed link mode is Cyclic mode means the transmission cycle in the Cyclic mode of the input module. The transmission cycle is as follows.

(4)

High-speed link transmission cycle(msec)	Reference
5	
10	
20	
50	
100	
200	Default value
500	
1000	

The transmission cycle of the output module follows the data transmission cycle of the high-speed link.

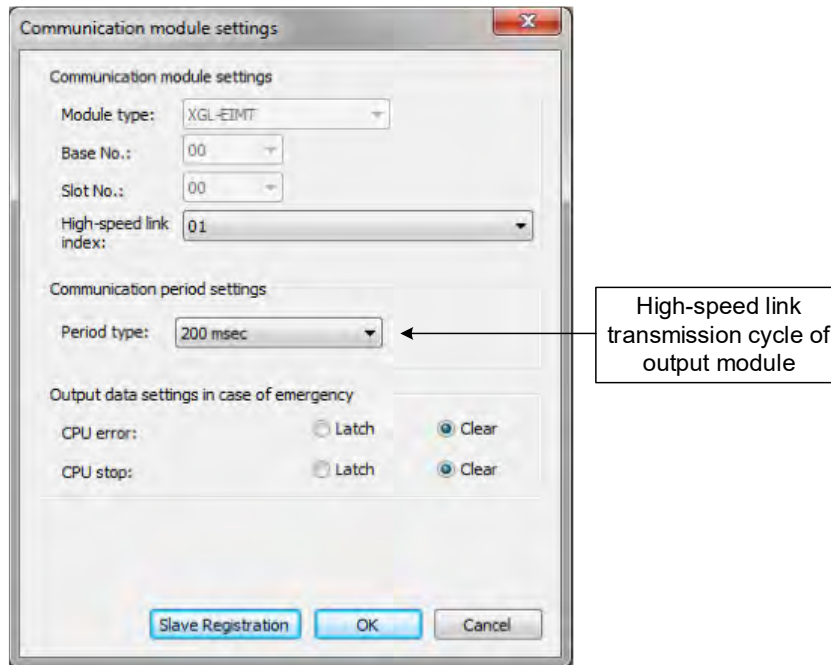

Minimum transmission prohibition time

It is a function that is enabled when the high-speed link transmission mode is CoS, and the time means the minimum interval for transmission in the CoS mode.

Since if the non-periodical data transmission occurs frequently, it affects the network load of the entire system, the data is transmitted only if the input value is changed to more than the setting time, when the data of input module occurs non-periodically.

(5)

Remarks
<p>1.Examples of network load calculations according to the minimum transmission prohibition time</p> <p>If the data of the input module is changed to the unit of 2msec</p> <p>1) When the minimum transmission prohibition time is set to 2msec</p> <p>(1) Packets per second(pps)= $1/0.002 = 500\text{pps}$</p> <p>(2) 5,000pps(XGL-EIMT allowable packet amount(3,600pps)exceeded) when 10 units are configured with the module of the same condition</p> <p>2) When the minimum transmission prohibition time is set to 200ms</p> <p>(1) Packets per second(pps)= $1/0.2 = 5\text{pps}$</p> <p>(2) 50pps when 10 units are configured with the module of the same condition</p> <p>2. If the data change cycle of the input module is less than the minimum transmission cycle (5msec), it is recommended to select Cyclic mode as the high-speed link transmission mode for stable system operations.</p>

Input filter

(6)

This function is enabled only in case of the digital input module, and it supports the input filter function to prevent the processing of invalid values caused by external noise. It means that only when the data is maintained at more than the input filter value, it is processed into valid data, and it is required to set the input filter value in consideration of the use environment.

Setting range of input filter (msec)	Reference
1	
3	Default Value
5	
7	
10	
20	
70	
100	

(7)

Emergency output module

It is a function that is enabled only in case of the output module type. When the network configuration is disconnected physically during normal communication with master module, the existing output data can be set to latch mode and clear mode.

Name	Meaning	Reference
Latch	It maintains the existing output module when the communication is physically disconnected with the master module.	
Clear	It initializes the existing output data to 0 when the communication is physically disconnected with the master module.	Default value

4) Module parameter setting item

Module parameter is an item that can be set only in case of the analog I/O module, and setting details for each product are as follows.

GEL-AV8C

(1)

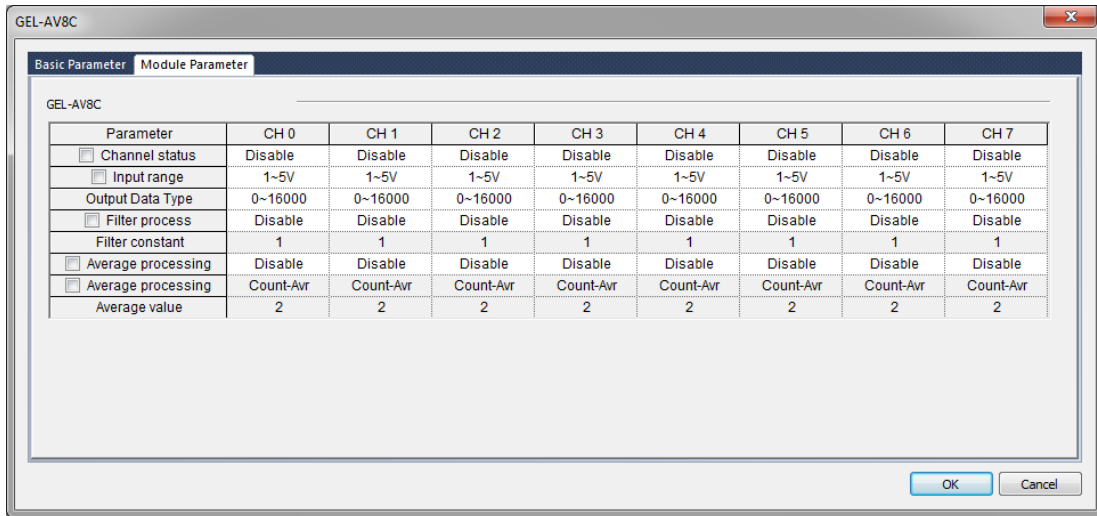

No.	Classification	Specification		
1	Channel Operation	Stop / Run		
2	Input voltage range	1~5V, 0~5V, 0~10V, -10~10V		
3	Output data type	Unsigned value	0 ~ 16000	
		Signed value	-8000 ~ 8000	
		Precise value	1 ~ 5 V	1000 ~ 5000
			0 ~ 5V	0 ~ 5000
			0~ 10V	0~ 10000
Percentile value	-10~10V	-10000~10000		
4	Filtered	Prohibition or Allowance		
5	Filter constant	1~99		
6	Average processing	Prohibition or Allowance		
7	Average method	Average number / Average time		
8	Average value	Average number (2~64,000), Average time (20~16,000)		

GEL-AC8C

(2)

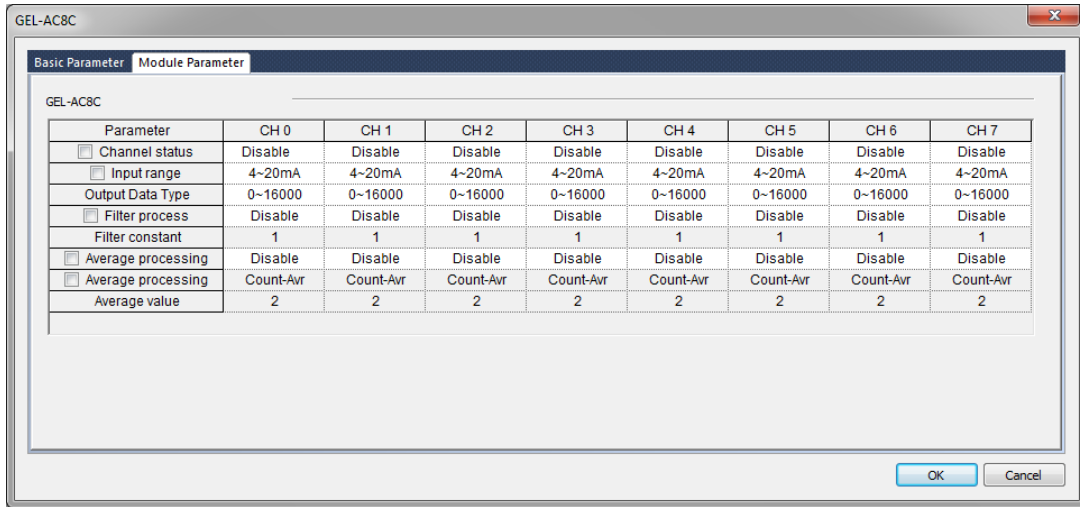

No.	Classification	Specification		
1	Channel Operation	Stop / Run		
2	Input voltage range	4~20mA / 0~20mA		
3	Output data type	Unsigned value	0 ~ 16,000	
		Signed value	-8,000 ~ 8,000	
		Precise value	4 ~ 20 mA	4,000 ~ 20,000
			0 ~ 20 mA	0 ~ 20,000
Percentile value	0 ~ 10,000			
4	Filtered	Prohibition or Allowance		
5	Filter constant	1~99		
6	Average processing	Prohibition or Allowance		
7	Average method	Average number / Average time		
8	Average value	Average number (2~64,000), Average time (20~16,000)		

GEL-DV4C

(3)

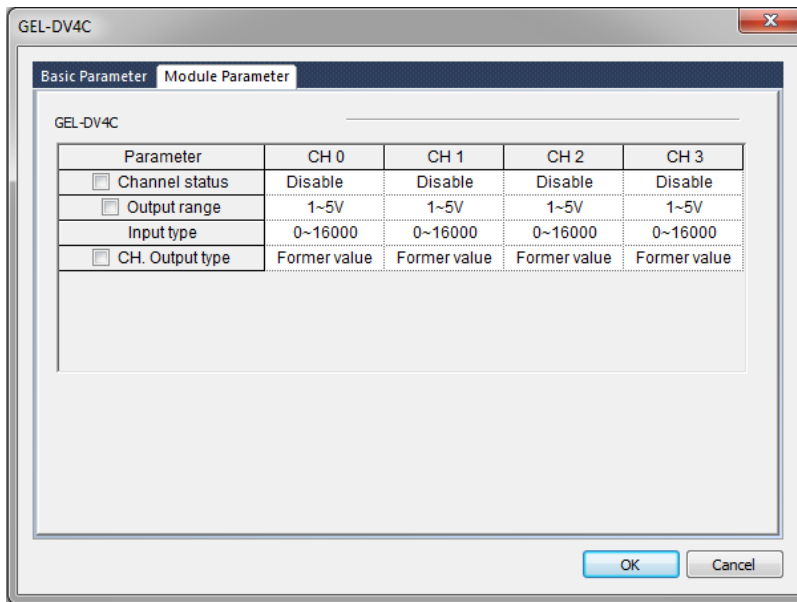

No.	Classification	Specification		
1	Channel Operation	Stop / Run		
2	Output voltage range	1~5V , 0~5V, 0~10V, -10~10V		
3	Input data type	Unsigned value	0 ~ 16,000	
		Signed value	-8,000 ~ 8,000	
		Precise value	1~5V	4,000 ~ 20,000
			0 ~ 5V	0 ~ 20,000
			0~10V	0~10,000
-10~10V	-10,000~10,000			
Percentile value	0 ~ 10,000			
4	Channel output status	Previous value/ Min. value/ Middle value/ Max. value		

GEL-DC4C

(4)

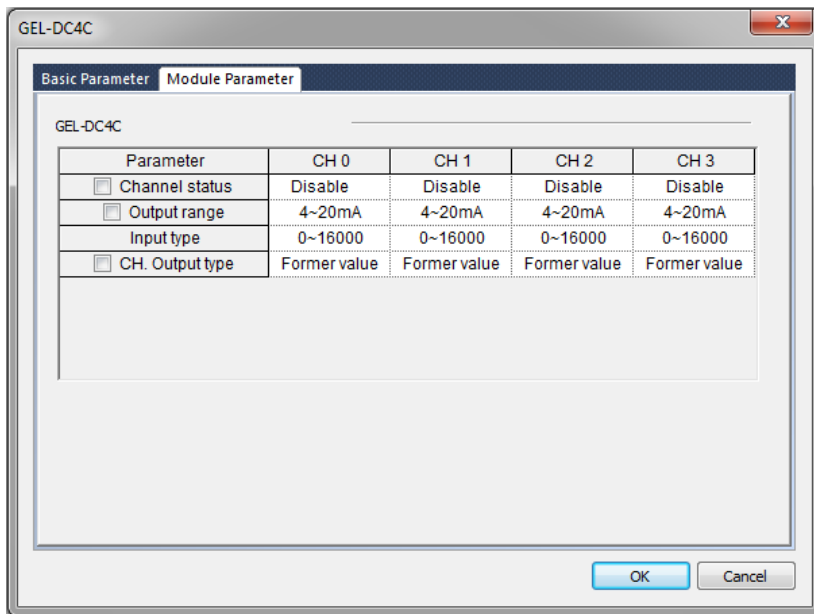

No.	Classification	Specification		
1	Channel Operation	Stop / Run		
2	Output voltage range	4~20mA or 0~20mA		
3	Input data type	Unsigned value	0 ~ 16,000	
		Signed value	-8,000 ~ 8,000	
		Precise value	4 ~ 20 mA	4,000 ~ 20,000
			0 ~ 20 mA	0 ~ 20,000
Percentile value	0 ~ 10,000			
4	Channel output status	Previous value/ Min. value/ Middle value/ Max. value		

11.4.2 High-speed link setting

High-speed link is a method of communication between XGT PLC communication modules, and it is a data transmission service that can send and receive data by high-speed parameter setting and allows users to exchange data by setting the transmitting and receiving data size, transmission and reception cycle, transmission and reception area and storage area in the parameter with the use of XG5000. Smart I/O RAPIEnet can be used by synchronizing the slave parameter set value to the high-speed link block.

The high-speed link functions of RAPIEnet master module are as follows.

1) High-speed block setting function

If there are multiple transmission and reception areas, the maximum of 128 (64 for XGB) blocks can be set up to 64 for transmission and 128 (64 for XGB) for reception.

The maximum of 200 words per block can be set.

(1) The maximum link point is available up to 19,200 words.

(2)
(3)2) Transmission and reception cycle setting function

Users can set the transmission and reception cycle ranging from 5msto 1s.

3) Transmission and reception area setting function

Transmission and reception area for each data block can be set depending on the set I/O address.

4) High-speed link information providing function

It provides users with high-speed link information as user keywords, which facilitates construction of reliable communication system.

The communication high-speed link points are as follows, and the basic point is 1 word.

Product	Maximum communication point	Maximum reception point	Maximum block number	Maximum point per block
XGK CPU	12,800	12,800	128(0-63)	200
XGI CPU	12,800	12,800	128(0-63)	200
XGB CPU	12,800	12,800	64(0-63)	200

5) High-speed link parameter settings

High-speed link parameter is selected in the high-speed link screen of XG5000, and the applicable item is set. The setting order and functions for each item are as follows.

In the case of high-speed parameter settings, methods on how to set in the online mode and offline mode are the same.

Addition of high-speed link communication

- a) Select [Add item] → [Add high-speed link communication] menu by clicking on the right mouse button after selecting XGL-EIMT registered as new on the network configuration screen. Or select [Project] → [Add item] → [Add s high-speed link communication] of XG5000 menu to perform the same function.

(1)

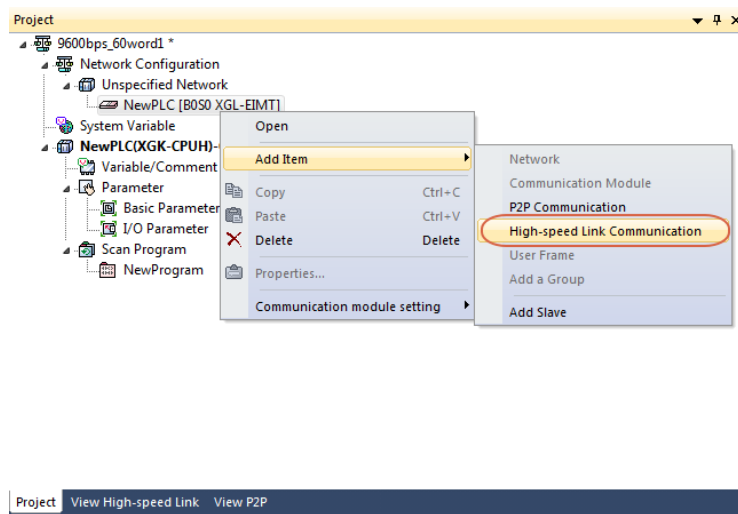

- b) [Communication module setting] window for setting the high-speed link communication is created.

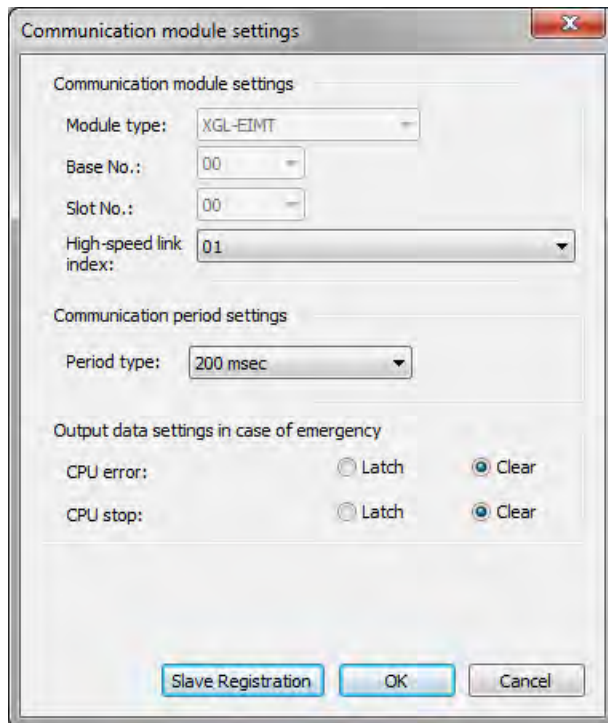

Communication module settings

The details of the master module that performs the high-speed link communication are as follows.

(2)

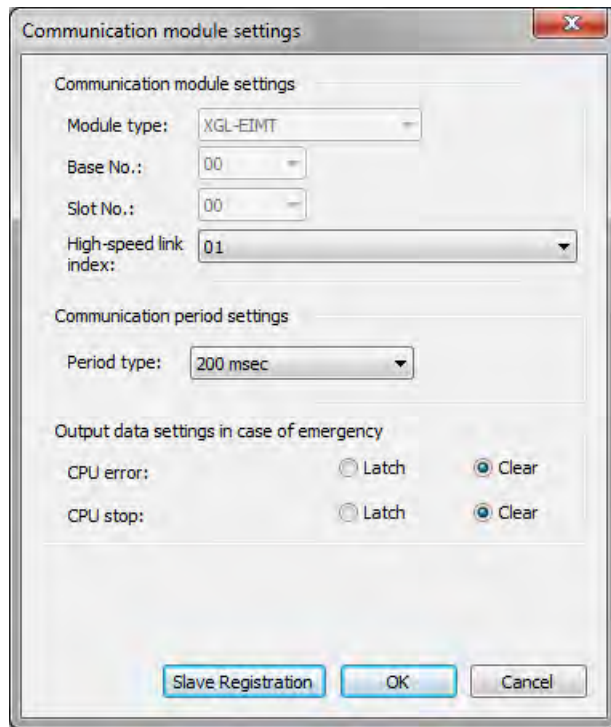

Items		Contents
Communication module setting	Module type	Set the installed communication module(RAPIEnet)
	Base number	Set the base position of the installed module(extension of 7 stages)
	Slot number	Set the slot location of the installed module(installation of up to 12 units) Setting range: 0~11 * For XGB, the maximum of 10 slots can be set.
Communication cycle setting	Cycle type	- Specify that the data is transmitted every set cycle. - Setting range: 5ms, 10ms, 20ms, 50ms, 100ms, 200ms, 500ms, 1s (operates 200ms in the case of the basic settings) - Reception data is updated every scan regardless of the communication cycle. - The same communication cycle is applied with respect to the entire transmission and reception block. - The data that can be transmitted once is four blocks, and it is divided into the unit of four blocks when exceeding four blocks, when the data size of one block doesn't matter.
Output data setting in case of emergency	CPU error	Set the output data in case of CPU error -Latch: Latched to the output just before the CPU error -Clear: Cleared to '0'
	CPU stop	Set the output data in case of CPU stop -Latch: Latched to the output just before the CPU stop -Clear: Cleared to '0'
Slave registration		Conduct synchronization of Smart I/O RAPIEnet with the high-speed link block - Need to register the slave module through the slave configuration in advance

High-speed link block settings

Click OK after setting the items required for the high-speed link service in the [Communication Module Settings], the high-speed link is added as shown below. Double click the added [High-speed link], the high-speed link block window is created.

(3)

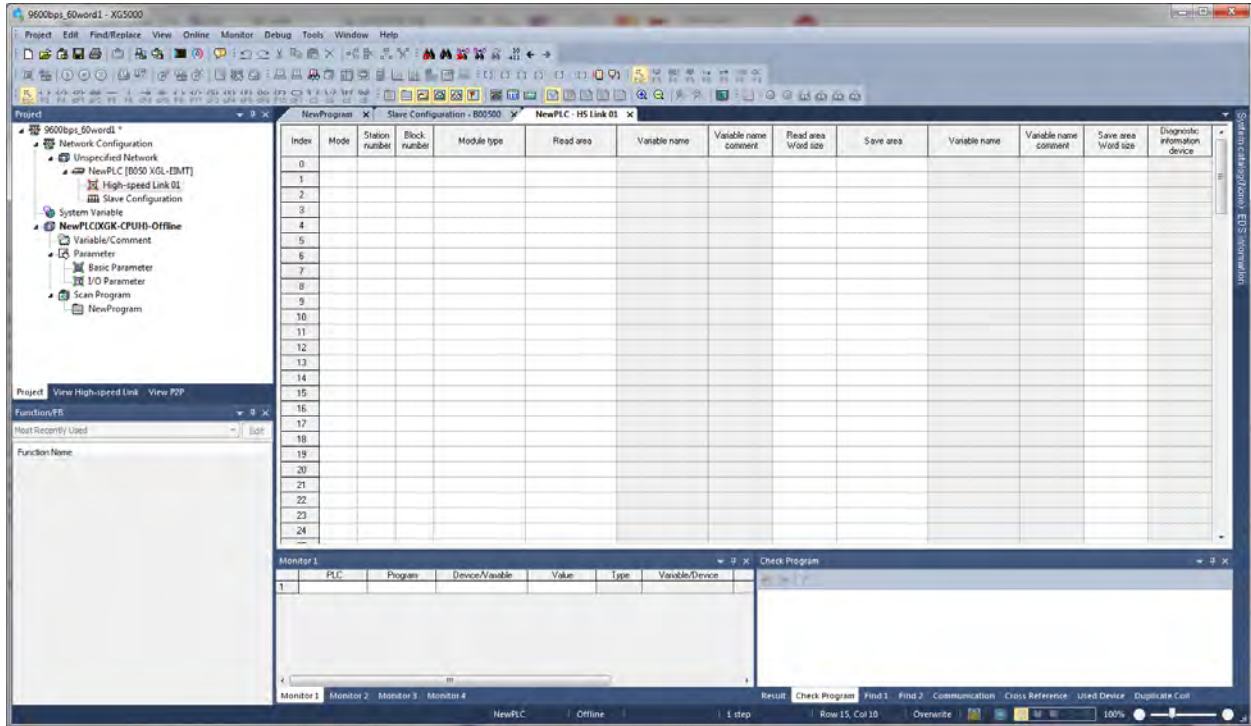

The details on the high-speed link block are as follows.

Index	Mode	Station number	Block number	Module type	Read area	Variable name	Variable name comment	Read area Word size	Save area	Variable name	Variable name comment	Save area Word size	Diagnostic information device
0													
1													
2													
3													
4													
5													
6													

Items		Contents	Reference
Index		Number of high-speed link blocks that can be set(0~127)	
Mode	Transmission	Transmit data	Mode
	Reception	Receive data	
	Transmission and reception	Transmit/receive data	
Station No.	RAPIEnet	Station number of data to be received: Setting range (0~63)	Station No.
	Smart I/O	Station No. of Smart I/O	

Remarks

If you proceed with the slave synchronization, Smart I/O is automatically set, except for the Read area/Save area.

Classification		Description	Reference
Block number ^{*Notice1)}		Setting transmission block/ reception block 1. Transmission block: Max 64block(Range: 0 ~ 63) 2. Reception block : Max 128block(Range: 0 ~ 63) * Transmission block, Reception block of XGB can be set up to 64 blocks	
Module type	RAPIEnet	RAPIEnet	Master module
	LS INVERTER	LS Inverter	When using inverter
	Smart I/O	Product name	
Read area		Specifying the address of the device that is used when the transmitting area - XGK: P,M,L,K,D,T,C,U,N,R,ZR - XGI: M,I,Q,R,W	
Variable		Indicates variable name of device when the device which is set for save area and read area has variable name.	
Variable description		Indicates variable description	
Word size of read area		Setting data size for transmission Data unit: Word Data range: 1~200	
Save area		Specifying the address of the device that is used when the receiving area - XGK: P,M,L,K,D,T,C,U,N,R,ZR - XGI: M,I,Q,R,W	
Word size of save area		Setting data size for reception Data unit: Word Data range: 1~200	
Diagnostic information save area ^{*Notice2)}		Diagnostic information save area of Smart I/O module	

Remarks

Notice1) Precautions when entering the block number

1. In case of entering the block number in transmission mode, if the block number is duplicated with that of Smart I/O, normal communication cannot be made.(Error occurs in writing the high-speed parameter)
2. Duplicate settings on the same block are prohibited in creating the transmission block.
3. Duplicate settings on the same station number are prohibited in creating the reception block, but duplicate settings are possible for the block number on the other station number.

Notice 2) Diagnostic information save area is displayed only when the diagnostic information use is selected in the slave configuration, and one word per slave module is automatically allocated .

1) Slave registration

Slave registration is a service to register the Smart I/O module set in the slave configuration window in the high-speed link block or set if the change of the subject for application is needed due to a change in network system among the Smart I/O modules registered in the high-speed link block.

The data communication through the high-speed link is possible only in case the Smart I/O is registered in the high-speed link block.

The registration of slave to be applied to the high-speed link block can be set by means of the method on how to register the slave of [Communication module setting] menu and the method on how to apply [Slave registration] in the high-speed link block.

Slave registration in communication module setting menu

a) Click [Communication module setting] → [Slave registration], and [RAPIEnet slave configuration apply] window is created.

b) Select the slave to be applied and then click Apply.*Notice1)

(1)

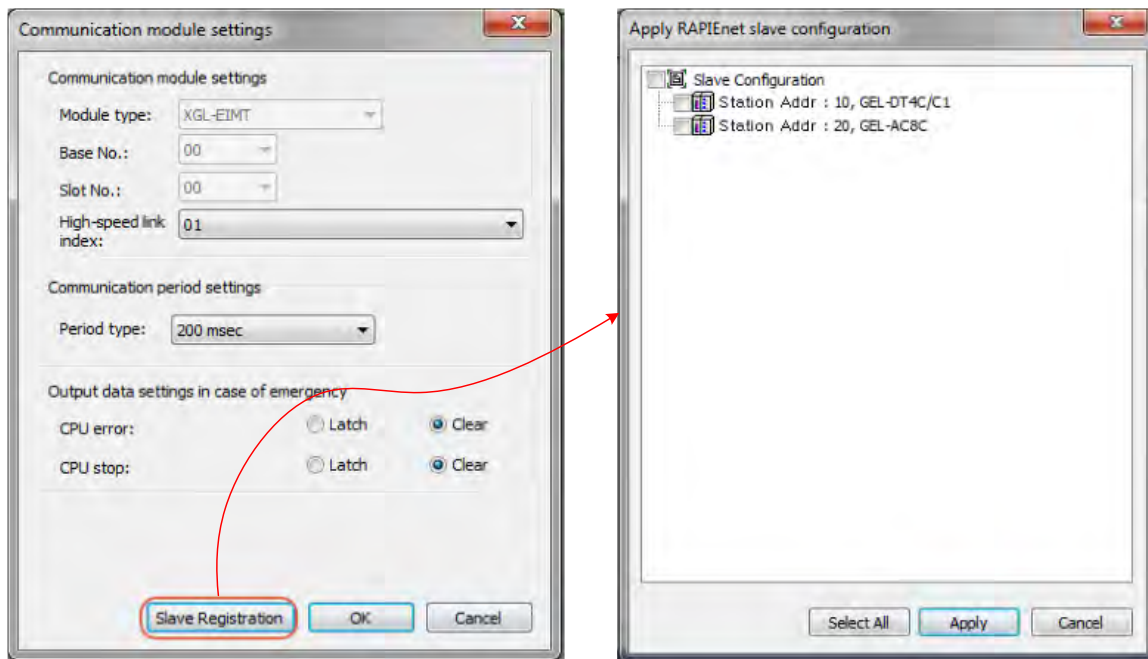

Remarks

Notice 1) Select the slave to be used by clicking the slave registration and then click Apply even when the change of the slave list within the high-speed link block is needed due to a change in the network system.

- c) Click [OK] of [Communication module setting] menu.
- d) Check if the selected Smart I/O is displayed in the high-speed link block window when double clicking [High-speed link 01].

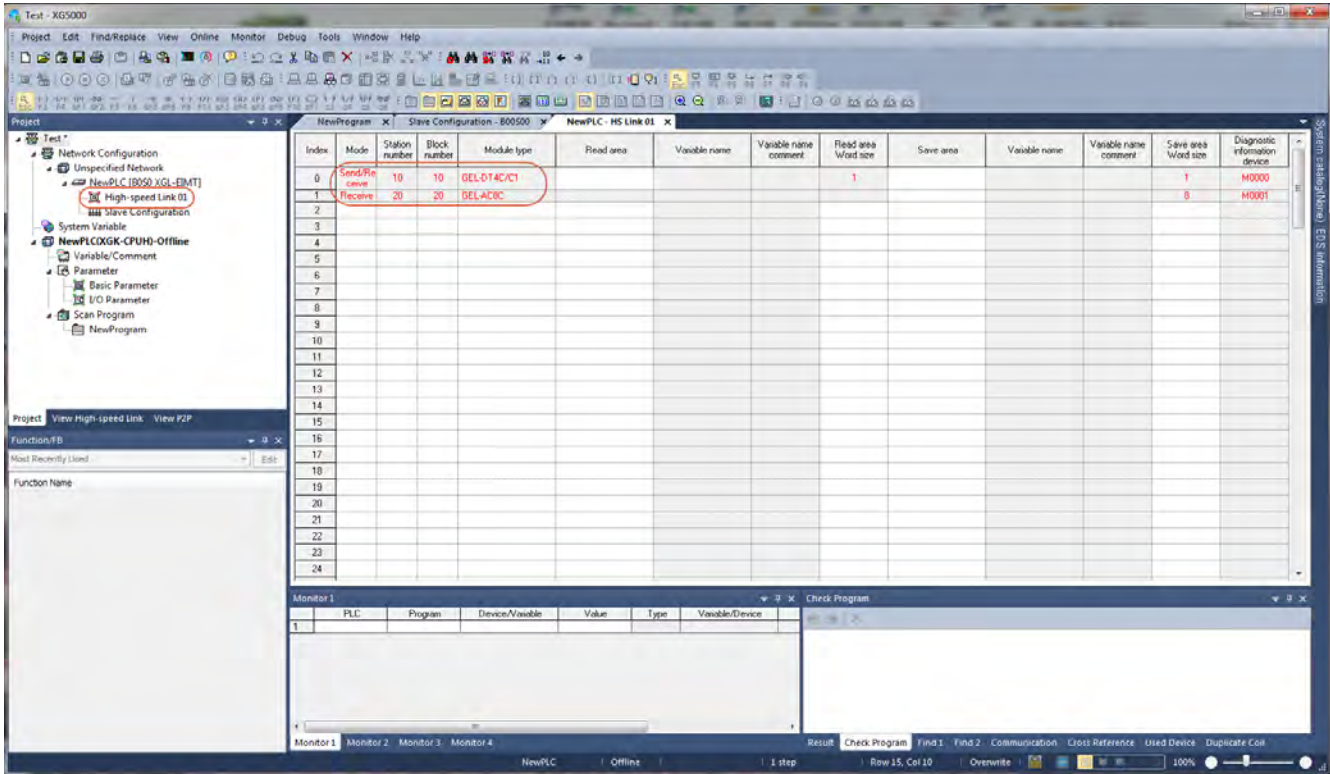

Slave registration within high-speed link block

- a) Double click [High-speed link 01] of [Project] window.
- b) Select any block of the high-speed link block, click the right mouse and then select [Slave registration].
- c) Select the slave to be applied and then click Apply.*Notice2)

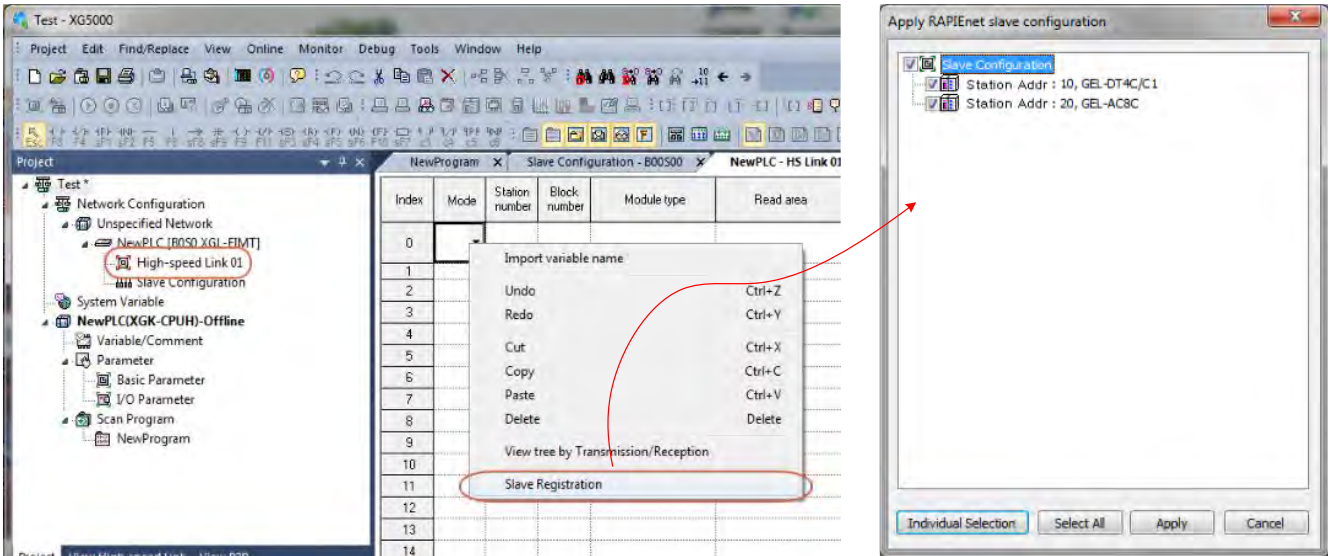

Remarks

Notice 2) Select the slave to be used by clicking the slave registration and then click Apply even when the change of the slave list within the high-speed link block is needed due to a change in the network system.

d) Check if the selected Smart I/O is displayed in the high-speed link block window.

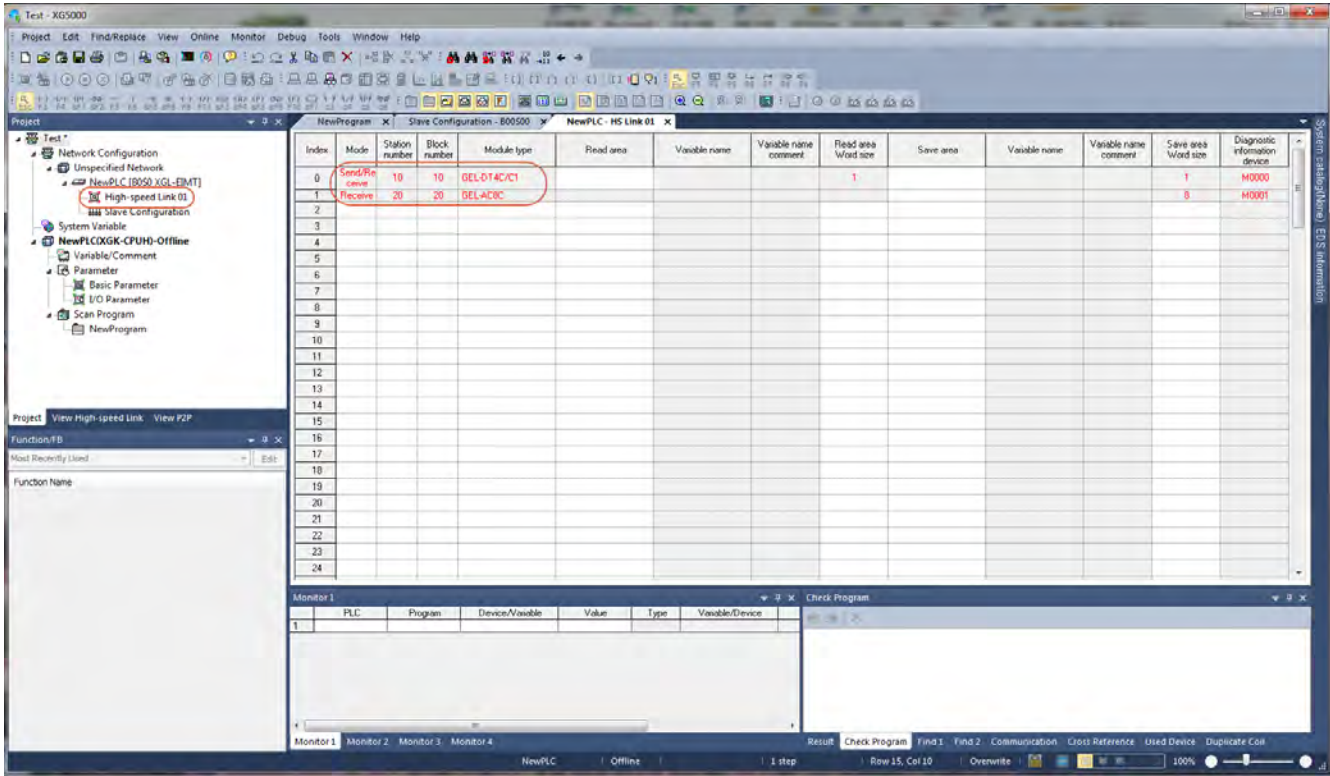

11.4.3 Writing Parameters and Link Enable

In order to use Smart I/O RAPIEnet, the high-speed link should be enabled after writing the high-speed link parameters and slave set above for normal communication. The procedures for writing parameters and link enable are as follows.

- 1) Click [Online] → [Connect] of XG5000 menu and connect to the PLC.
- 2) Click [Online] → [Write].
- 3) Check the items in [Write] menu and click [OK], when if [Set Link Enable together] is checked, Link Enable is also executed after writing the set high-speed link parameters.

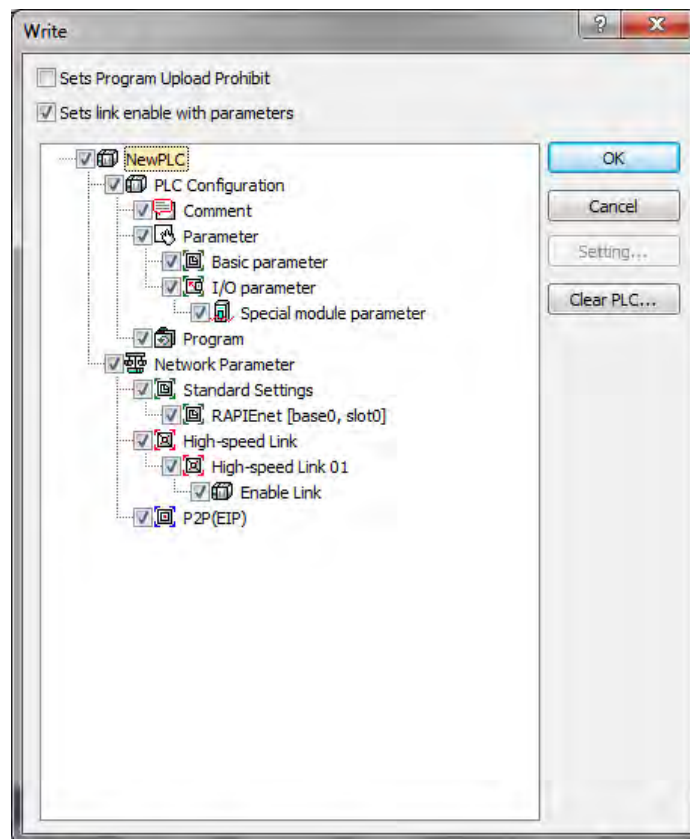

Remarks

In writing parameters, the slave parameter of the Smart I/O module is stored in RAPIEnet master module, and the high-speed link parameter in CPU, respectively.

Therefore, if [Basic setting] → [RAPIEnet] of [Network parameter] is checked and downloaded after changing the parameter in case a change in the slave parameter occurs, the changed parameter is applied.

11.4.4 Smart I/O Communication Setting Example

1) System Configuration
System Configuration

(1)

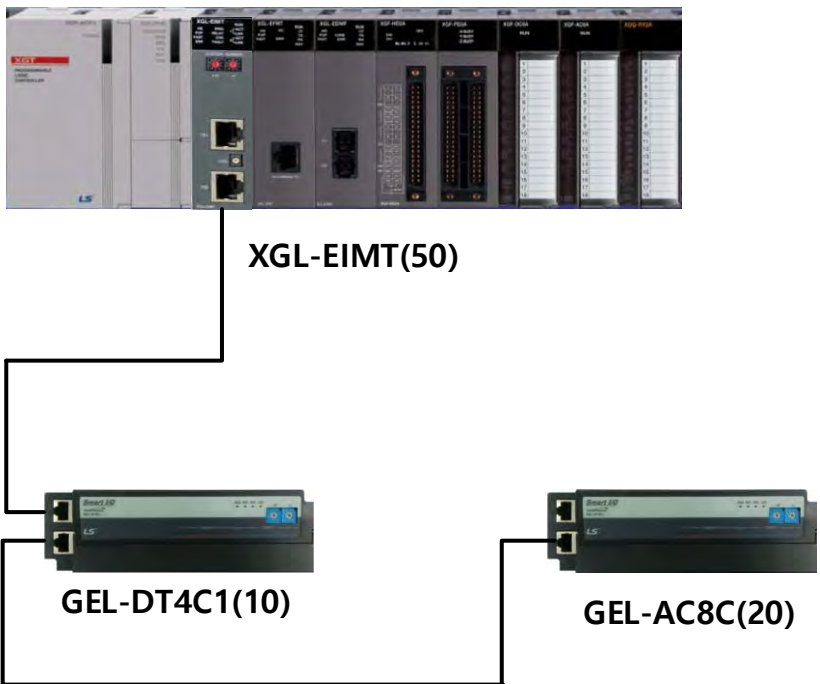

(2) Module Information

Classification	Name	Description	Reference
CPU	XGK-CPUH	1. Read area: M100 2. Save area: M200 3. Diagnostic area: M300	-
RAPIenet Master	XGL-EIMT	1. High-speed link information: 01 2. High-speed link cycle: 200msec	Master Station address 50
Smart I/O	GEL-DT4C1	1. Station address: 10	-
	GEL-AC8C	1. Station address: 20	-
Parameter	Basic parameter	1. Heartbeat cycle: 1000msec 2. Diagnostic area: Use 3. High-speed link transmission mode: Cyclic 4. High-speed link transmission cycle: 200msec 5. Data transmission: Unicast 6. Input filter: 3msec 7. Emergency Output Mode: Clear	1. Input filter: Only for GEL-DT4C1 2. Emergency output mode: Only for GEL-DT4C1
	Module parameter	1. Input range: 4~20mA 2. Output data type: 0~16,000 3. Average processing: Prohibition	Common for all channels

2) Project creation

Project creation

a) Run XG5000 and select [Project]→[New project]. Select the CPU series and type by referring to the module information of the system configuration.

(1)

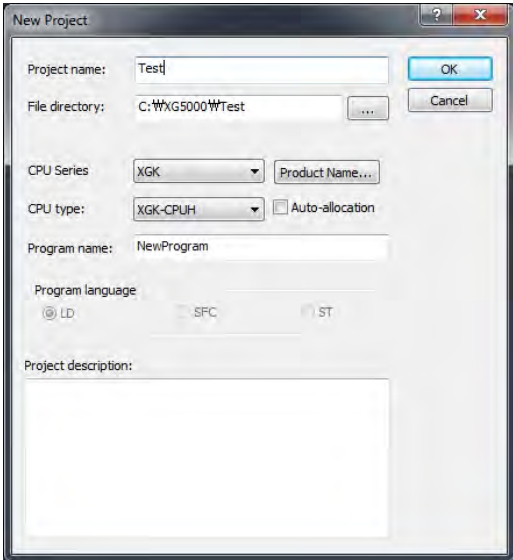

b) Click OK after entering the basic information necessary to create the project.

3) Smart I/O parameter settings

Methods on how to set Smart I/O parameters are divided into a setting method in online mode in which XG5000 is connected to CPU and an off-line setting method.

(1)

Setting in the online mode

a) Slave configuration window creation

- (a) Connect to PLC via [Online]→[Connect] of XG5000 menu.
- (b) Change to [Online]→[Mode]→[Stop] for I/O parameter synchronization.
- (c) Select [Online]→[Diagnosis]→[I/O information], and I/O information window is shown below.

Click I/O synchronization and proceed with the synchronization of the module installed between CPU and base.

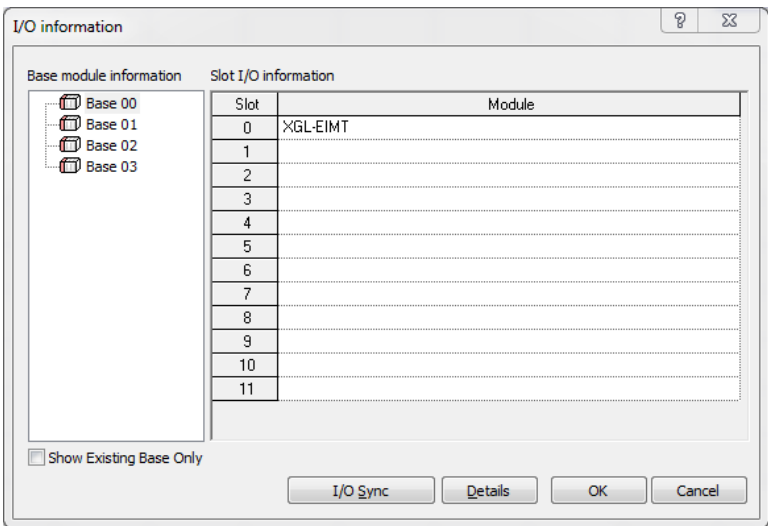

- (d) Click I/O synchronization, and the message that indicates I/O parameters are overwritten to the PLC is generated. Click [OK].

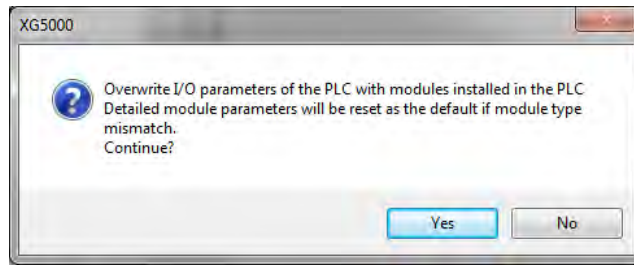

- (e) Check if XGL-EIMT module is registered in the project window [Network Configuration][Basic Network].

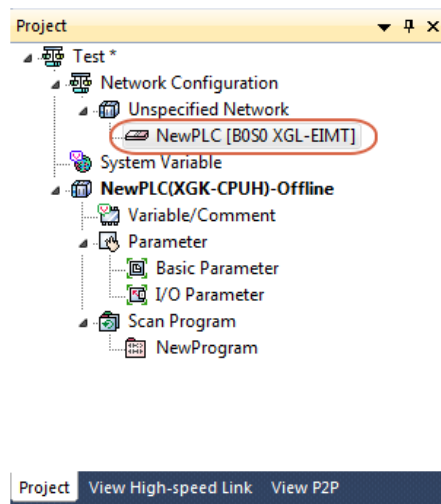

- (f) Select [Add item] → [Add slave] menu by clicking on the right mouse button after selecting XGL-EIMT registered as new on the network configuration screen. Or, select [Project] → [Add item] → [Add slave] of XG5000 menu to perform the same function.

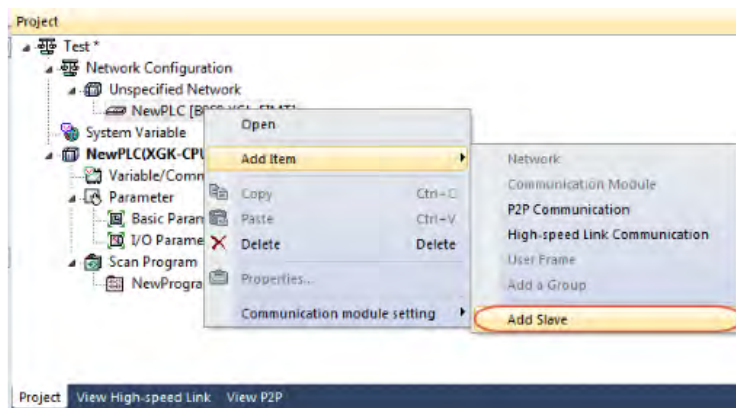

(g) Check if the slave configuration window is created.

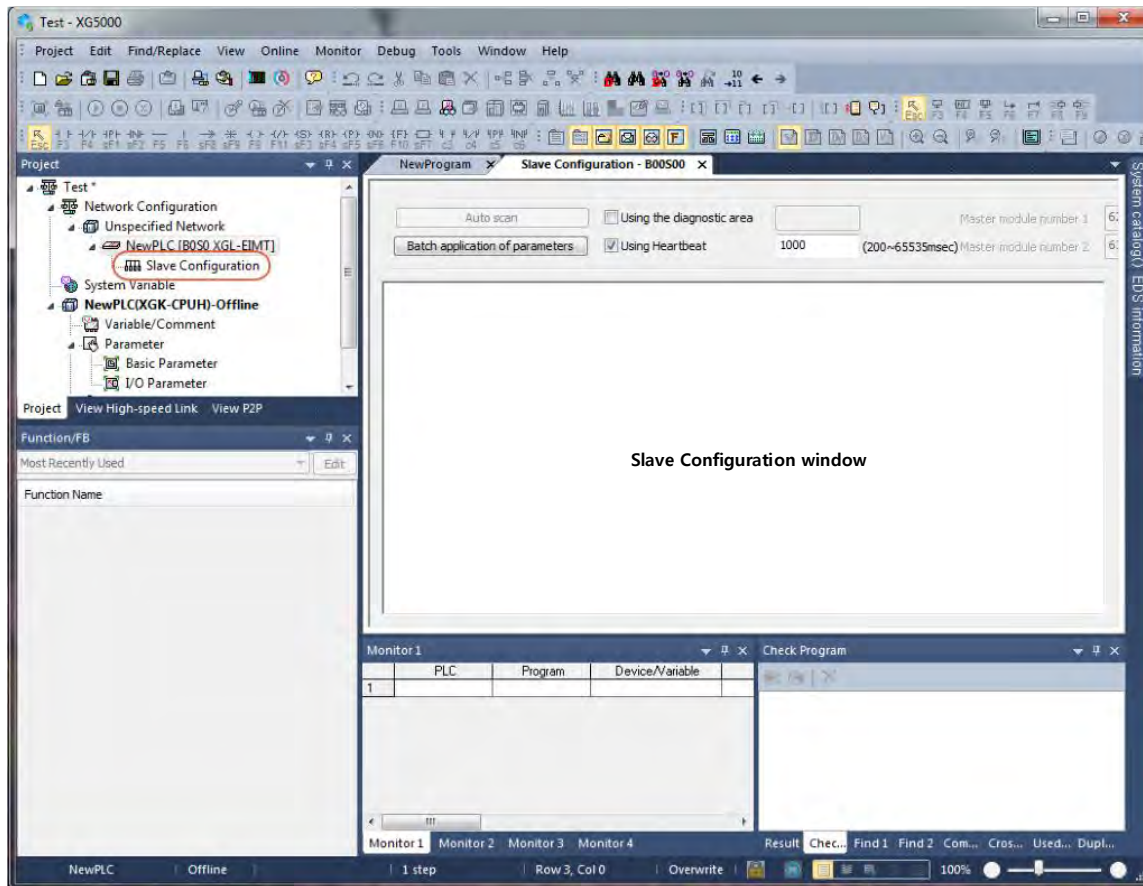

c) Slave module parameter settings

(a) Set the basic parameters required for the slave configuration.

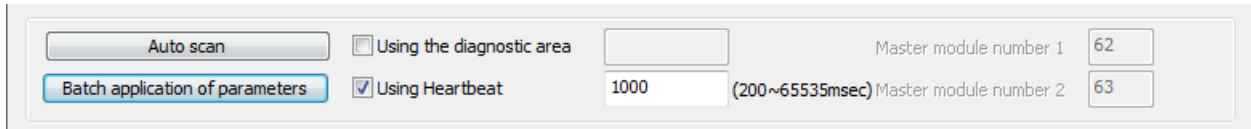

(b) Click [Auto scan].

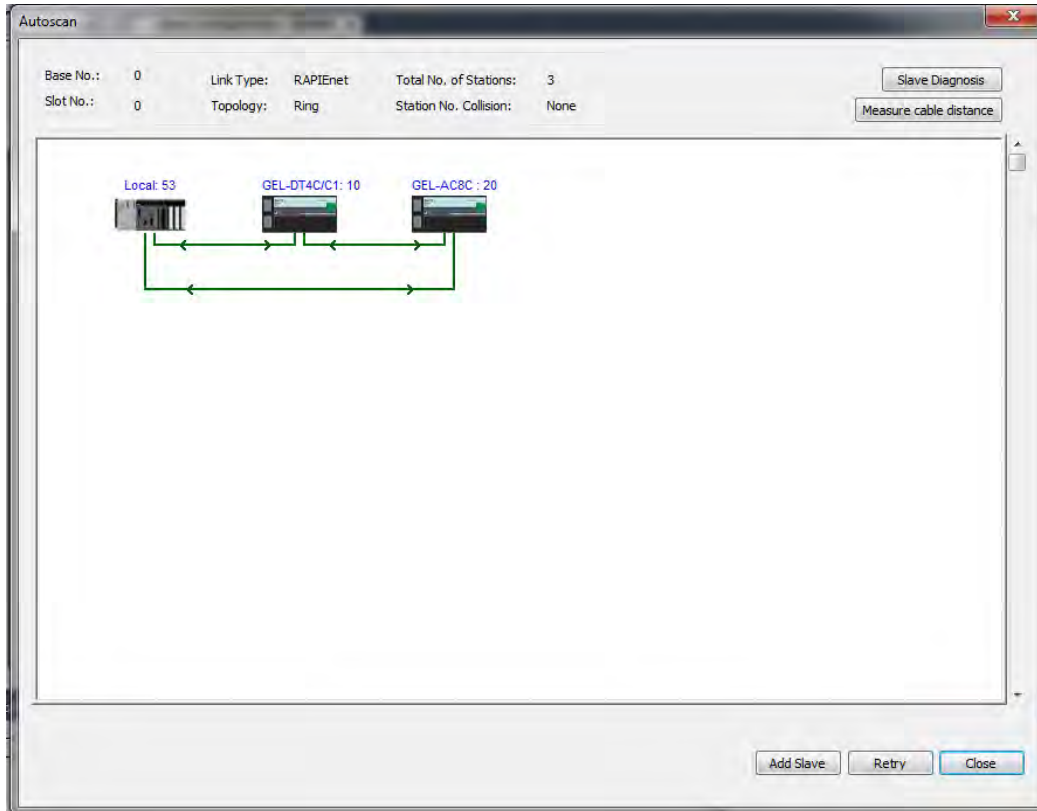

(c) Click [Add slave] to select the entire module. Click [OK].

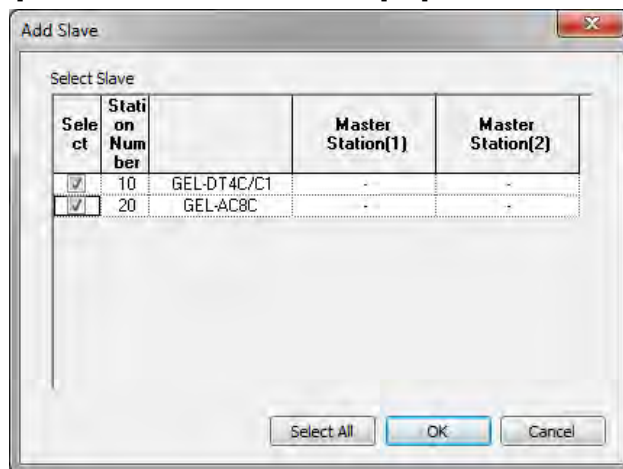

- (d) Check if the module name of the Smart I/O module added to the slave configuration window and station number are displayed.

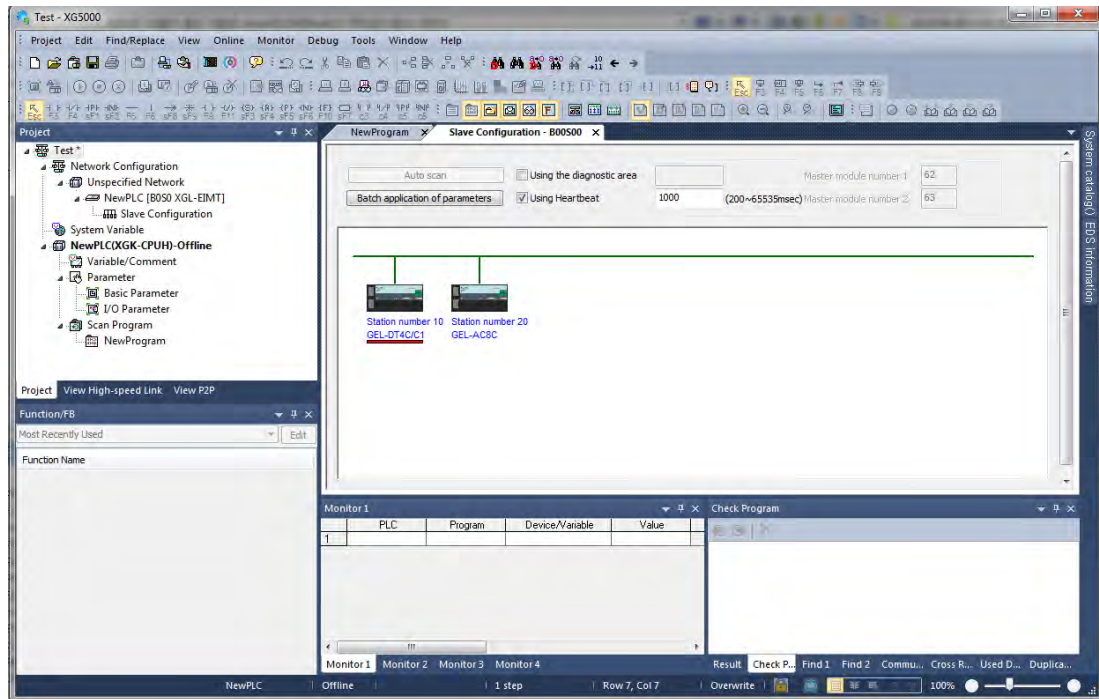

(e) Double click the GEL-DT4C1 in the slave configuration window to enter the parameters defined above.

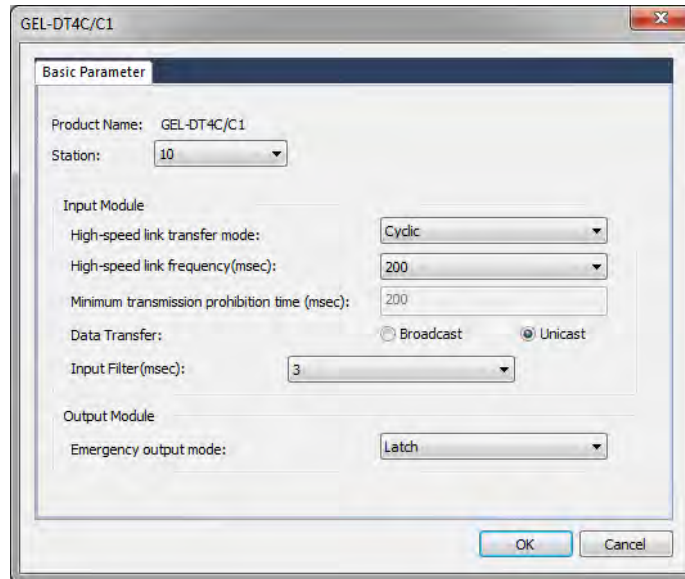

(f) Enter the parameters on the GEL-AV8C in the same way.

Setting in the offline mode

- a) Slave configuration window creation
 - (a) Double click the I/O parameter of the project window and then select XGL-EIMT as the application module to the slot number 0.

(2)

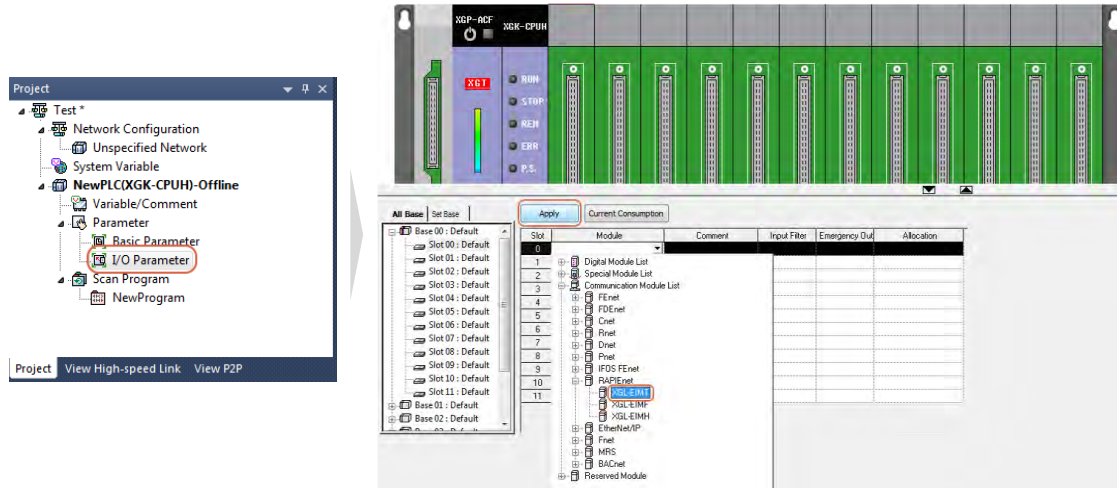

- (b) Click the application, and the message that indicates the module set in I/O parameter is registered is generated. Click [Yes].

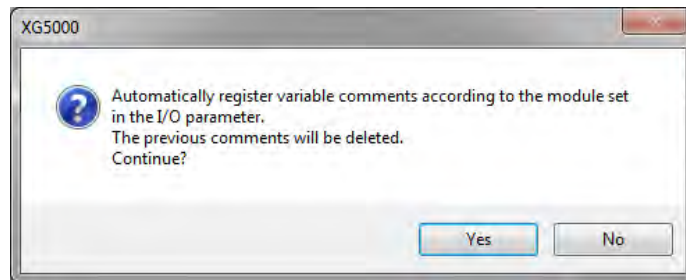

(c) Check if XGL-EIMT module is registered in the project window [Network Configuration][Basic Network].

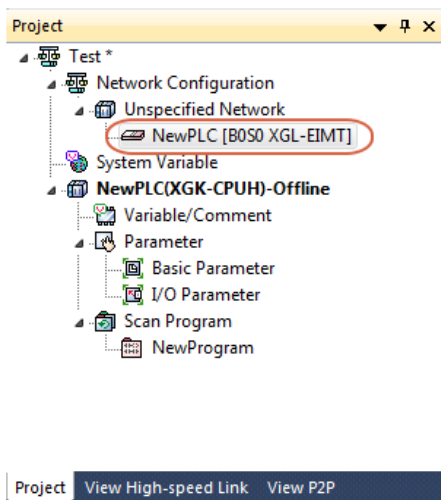

(d) Select [Add item] →[Add slave] menu by clicking on the right mouse button after selecting XGL-EIMT registered as new on the network configuration screen. Or, select [Project] →[Add item] →[Add slave] of XG5000 menu to perform the same function.

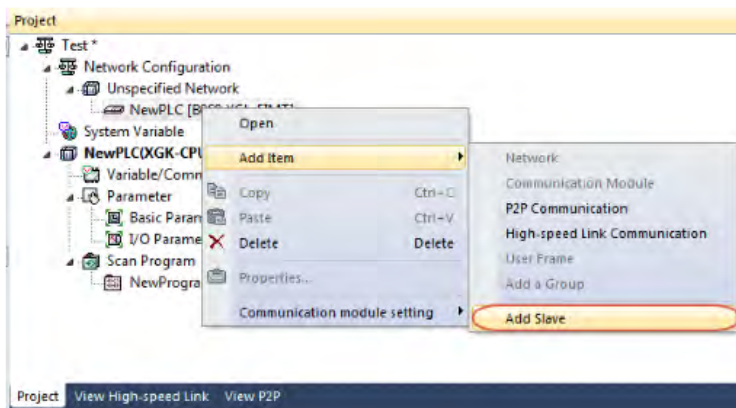

(e) Check if the slave configuration window is created.

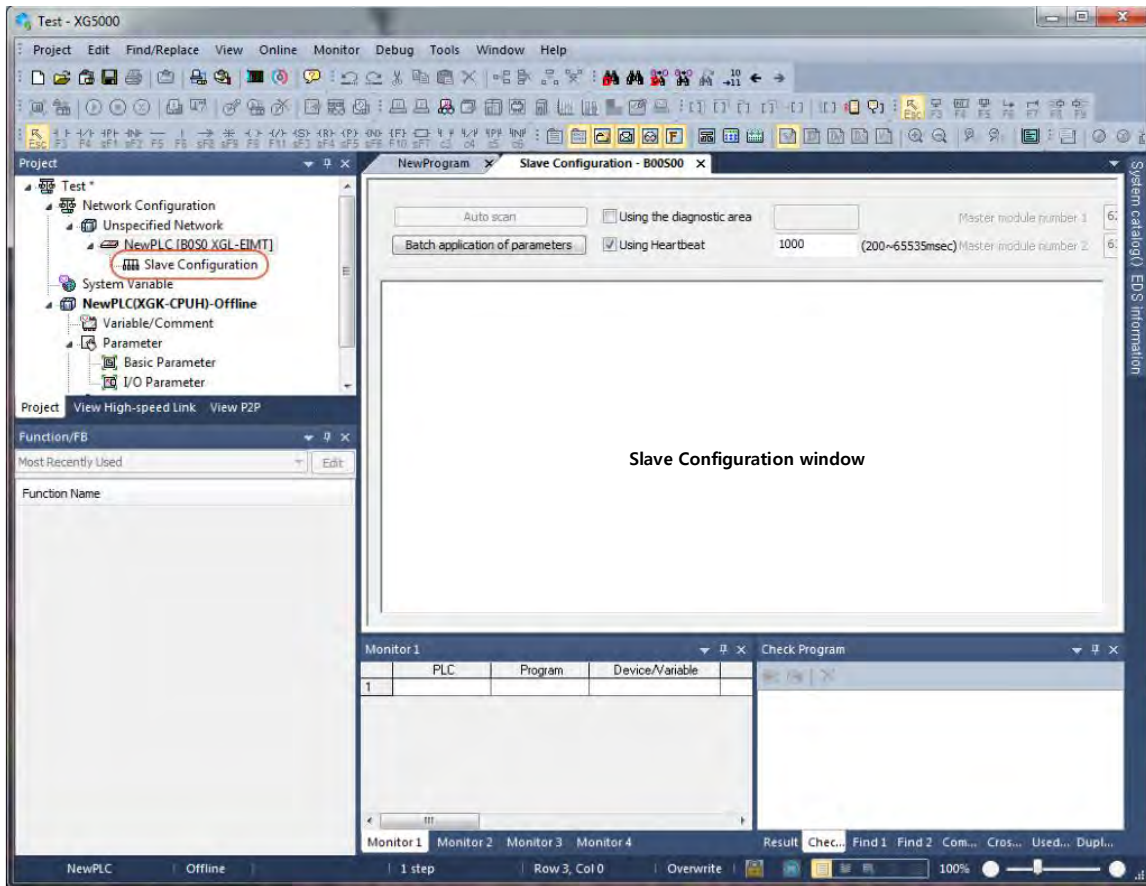

b) Slave module parameter settings

(a) Set the basic parameters required for the slave configuration.

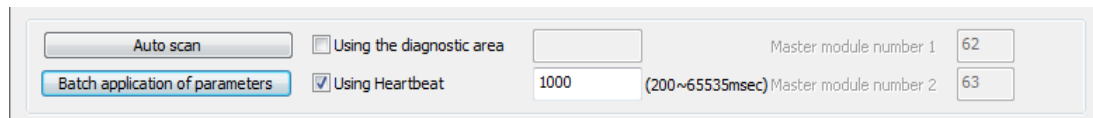

(b) Double click [GEL-DT4C1] after selecting the [System catalog] or click [OK] after entering the parameter values defined by selecting through drag-in to the [Slave configuration window].

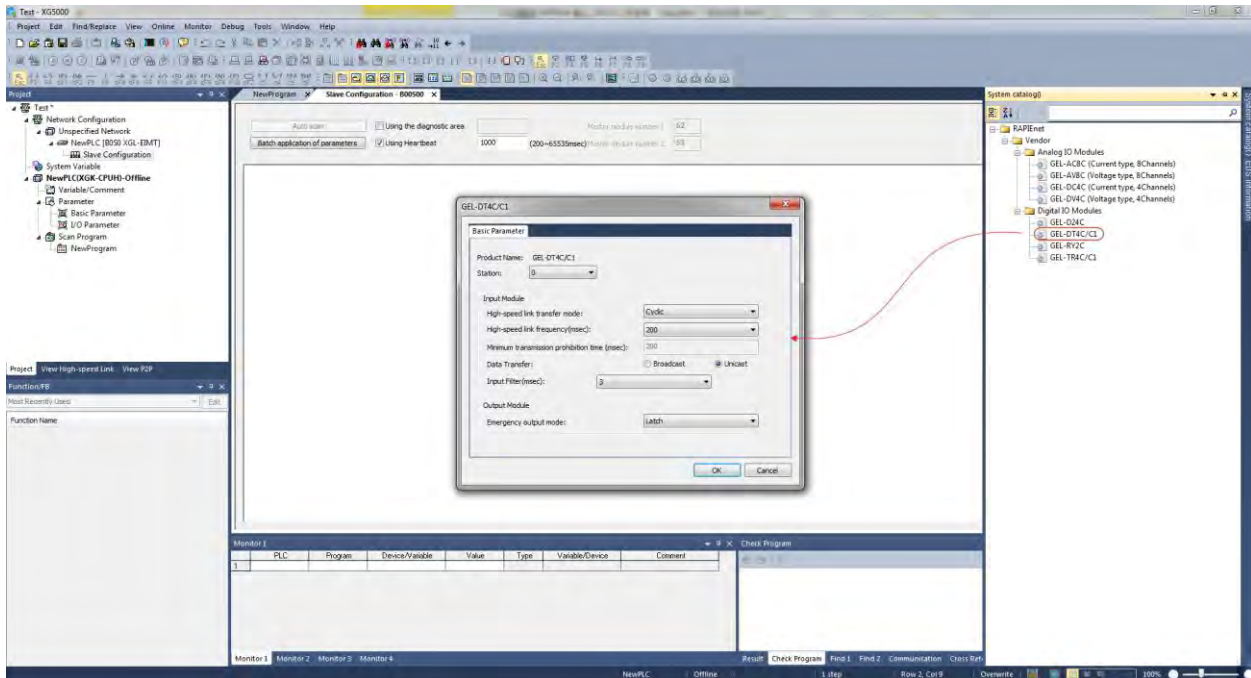

(c) Enter the parameters on the GEL-AV8C in the same way.

(d) Check if the module name of the Smart I/O module added to the slave configuration window and station number are displayed..

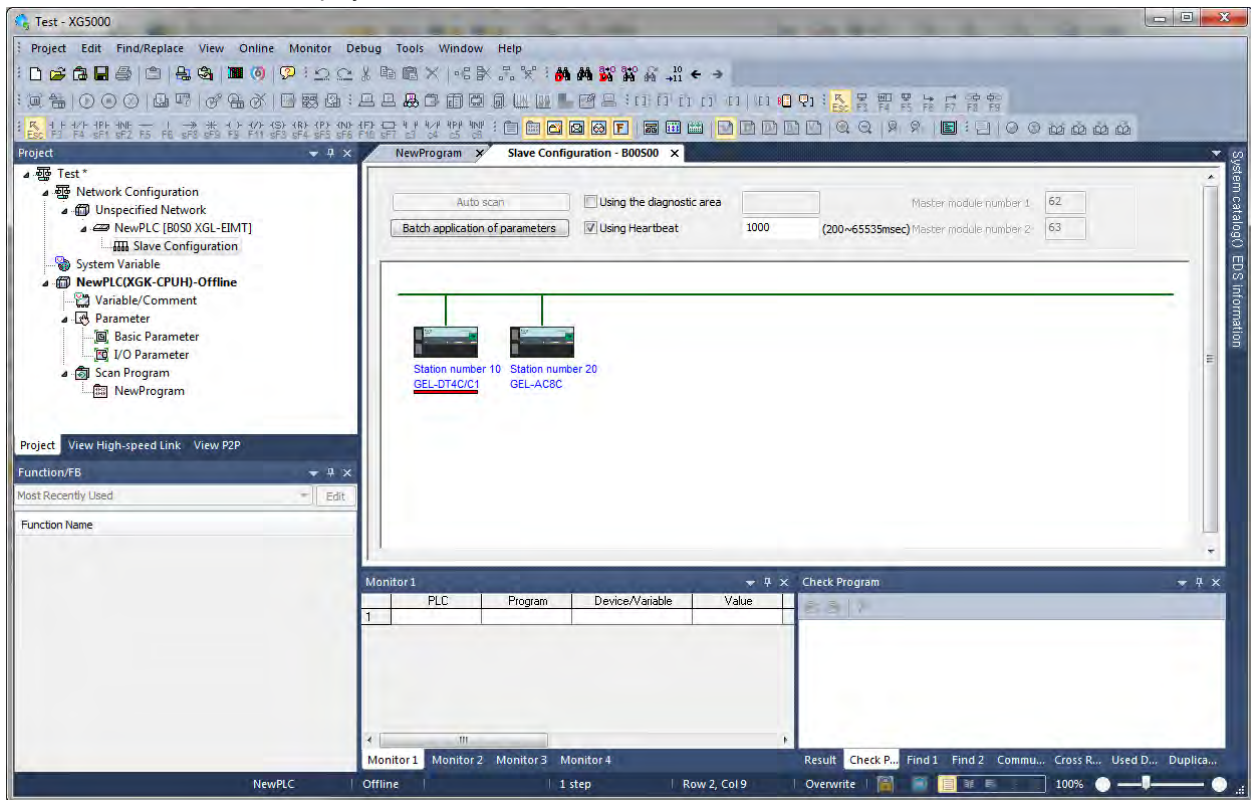

4) High-speed link parameter settings

In the case of high-speed parameter settings, methods on how to set in the online mode and offline mode are the same.

Addition of high-speed link communication

- a) Select [Add item] → [Add high-speed link communication] menu by clicking the right mouse button after selecting XGL-EIMT registered as new on the network configuration screen. Or select [Project] → [Add item] → [Add s high-speed link communication] of XG5000 menu to perform the same function.

(1)

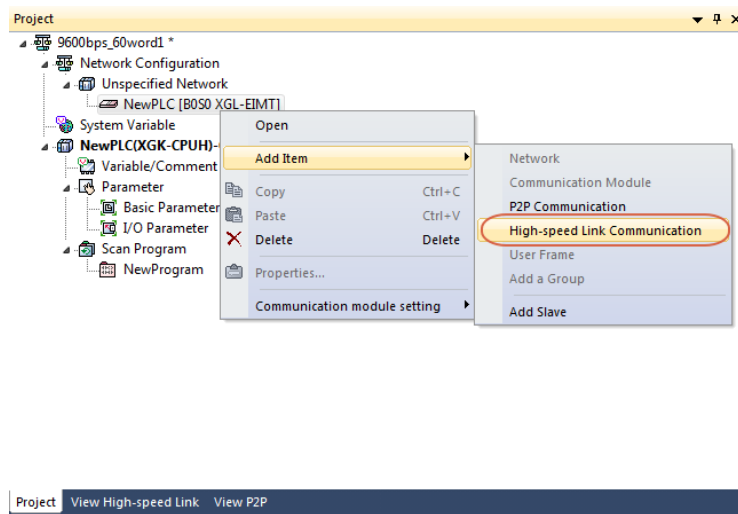

- b) Enter the high-speed link information of the master module to perform the high-speed link communication, when if the slave to be applied to the high-speed link block is conducted in the [Communication module setting] window, click the [Slave registration].

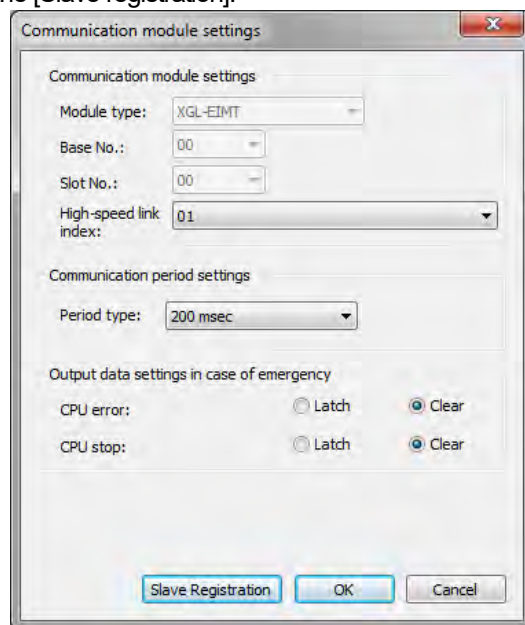

Run slave synchronization

The registration of slave to be applied to the high-speed link block can be set by means of the method on how to use the slave registration of [Communication module setting] menu and the method on how to apply [Slave registration] in the high-speed link block.

a) Slave registration in communication module setting menu

(2)

(a) Click [Communication module setting] → [Slave registration], and [RAPIenet slave configuration window apply]window is created

(b) Click Apply after clicking Select All.

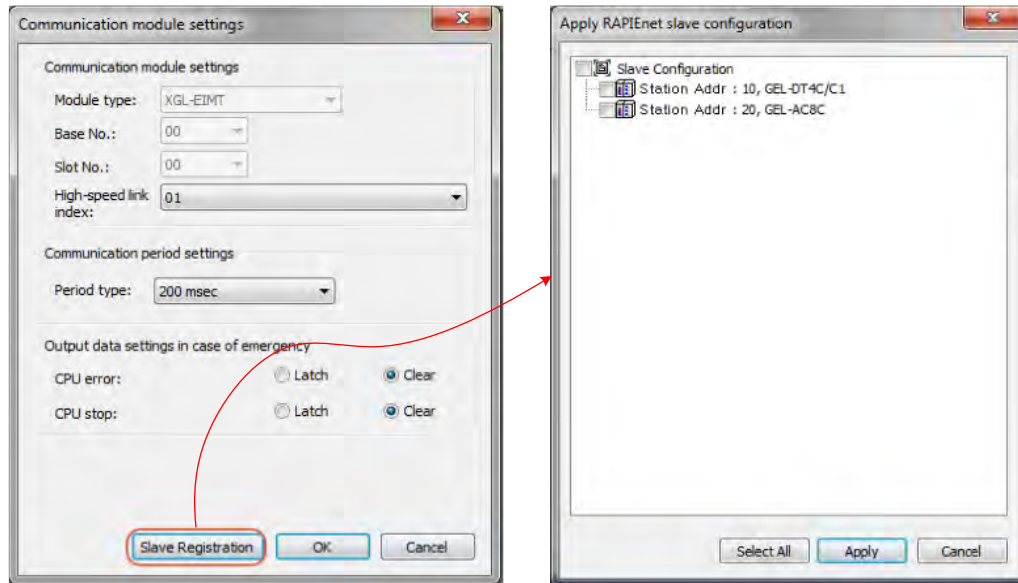

- (c) Click [OK] of [Communication module setting] menu.
- (d) Check if the selected Smart I/O is displayed in the high-speed link block window when double clicking [High-speed link 01].

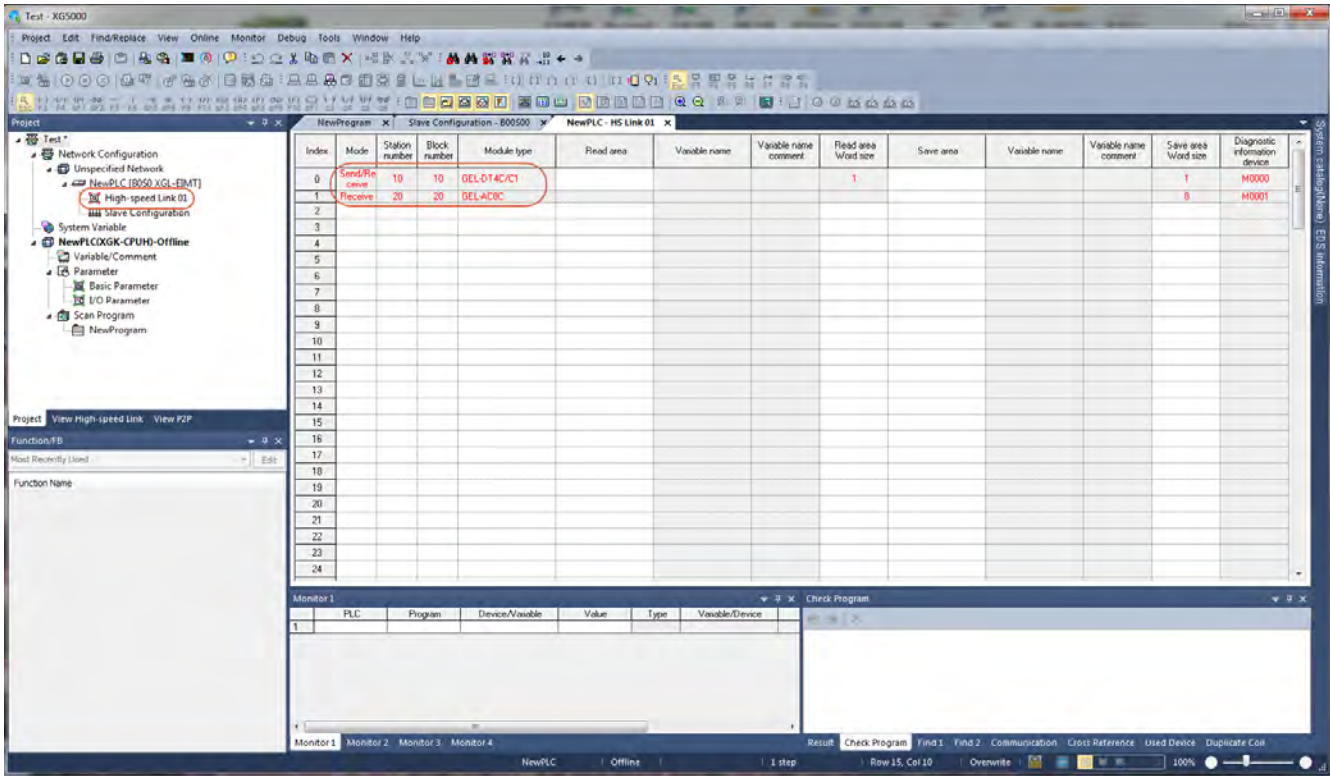

- b) Slave registration within high-speed link block
 - (a) Double click the [High-speed link 01] of [Project] window.
 - (b) Select any block of the high-speed link blocks, click the right mouse button and select [Synchronize slave configuration].
 - (c) Click Apply after clicking Select All.

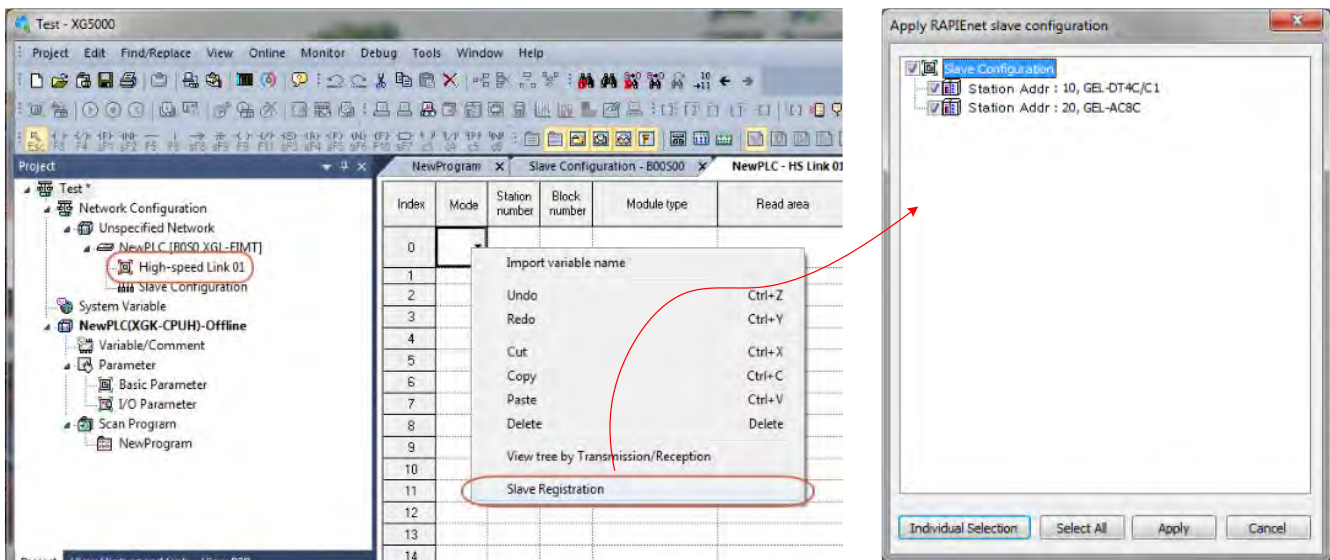

(d) Check if the selected Smart I/O is displayed in the high-speed link block window.

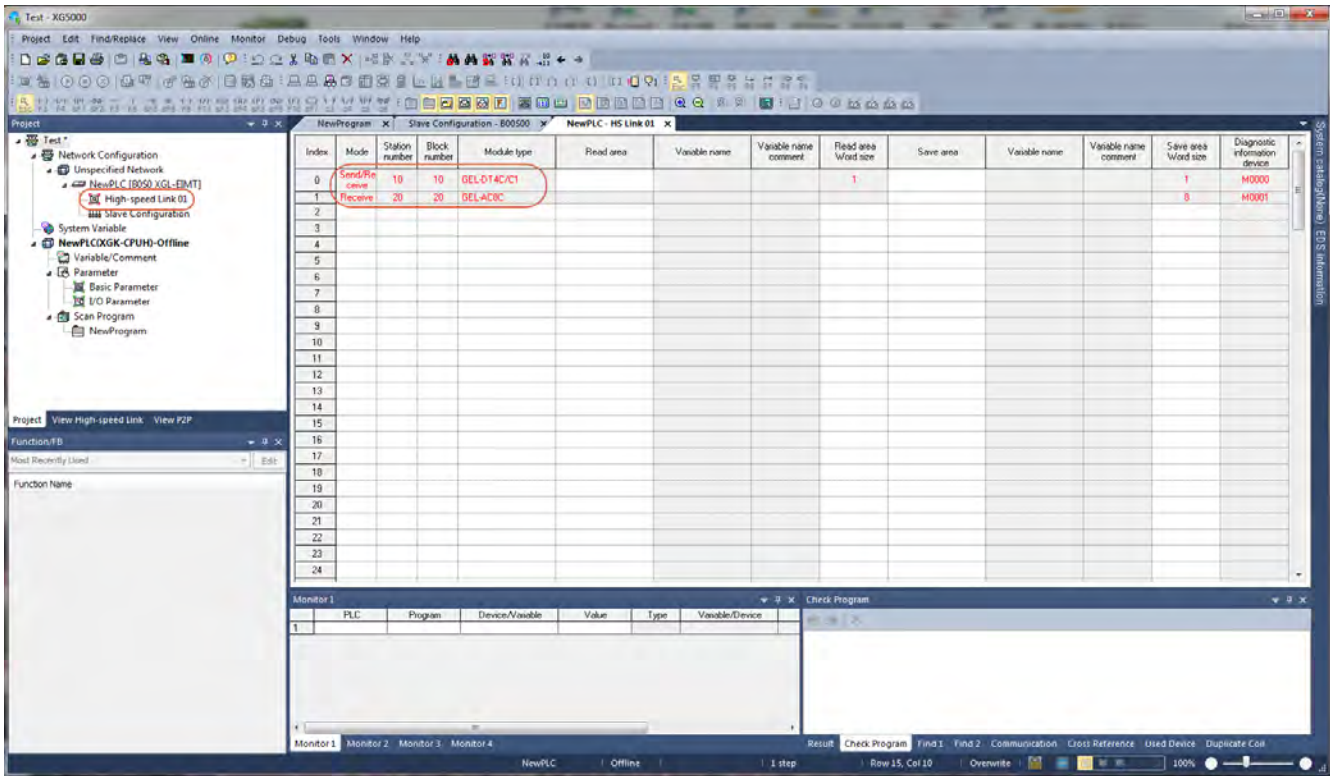

Remarks

1. Add and Remove Slave can be set only by the slave registration.
2. If the module station number registered in the slave configuration window does not match the station number registered in the high-speed link block due to a change in the slave configuration, the module type of the high-speed link is displayed as the module type mismatch. Please check the module information registered in the slave configuration window in this case.

5) PLC device area settings

Enter the Read area and Save area of each Smart I/O module by referring to the module information contents of the system configuration (Read area: M100, Save area: M200).

- GEL-DT4C1: Read area (M100), Save area (M200)
- GEL-AC8C: Save area (M201)

In the above device areas, the data of M100 is transferred to the output data of GEL-DT4C1 in the case of Read area, and the input data is received in Save area. For GEL-AC8C, the data of one word per channel is received based on the M201.

- (1)
- (2)

If the data of the high-speed link is entered correctly, the color of the text is changed to black as shown below

Index	Mode	Station number	Block number	Module type	Read area	Variable name	Variable name comment	Read area Word size	Save area	Variable name	Variable name comment	Save area Word size	Diagnostic information device
0	Send/Receive	10	10	GEL-DT4C/C1	M0100			1	M0200			1	M0300
1	Receive	20	20	GEL-AC8C					M0201			8	M0301
2													

6) Writing parameters and Link Enable

- (1) Click [Online] → [Connect] of XG5000 menu and connect to the PLC.
- (2) Click [Online] → [Write].
- (3) Check the items in [Write] menu and click [OK], when if [Set Link Enable together] is checked, Link Enable is also executed after writing the set high-speed link parameters.

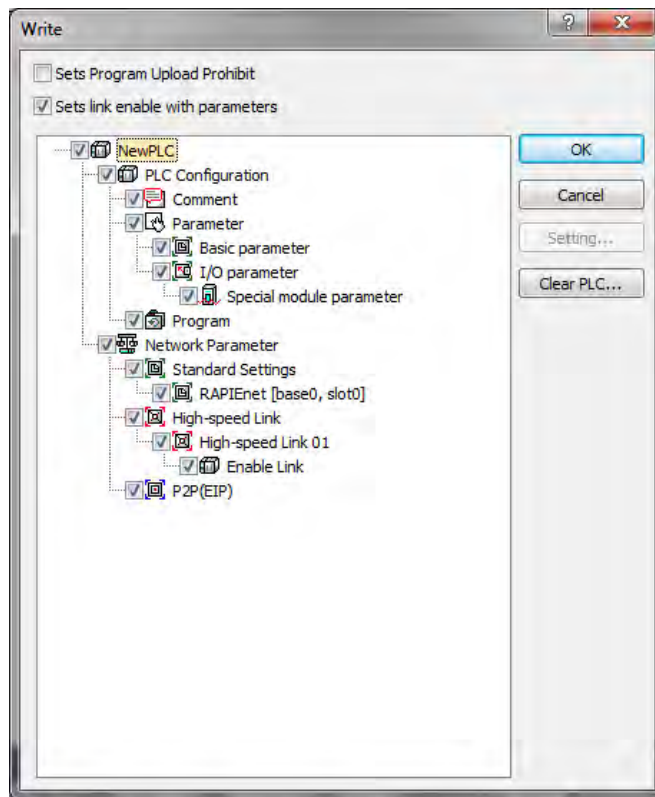

- (4) Check if normal communication is made by utilizing a diagnostic service function.

11.5 Diagnostic Functions

Smart I/O RAPIEnet provides S/W diagnostic function that can check the status within the network through the master module and H/W diagnostic function service that can identify the hardware status of the Smart I/O.

11.5.1 S/W diagnostic function

Smart I/O RAPIEnet makes it possible to check the communication status and information of each slave within the network through the diagnostic information provided by the master module.

1) How to use diagnostic function

Methods on how to switch screen for system diagnostics are as follows.

Click [Online→ Connect] and then click [Online→ Communication module setting→System diagnostics menu].

Or click [Network configuration→RAPIEnet master selection → Right mouse click → Communication module setting→ System diagnostics] menu to switch to the system diagnostic screen in the same manner.

(1)

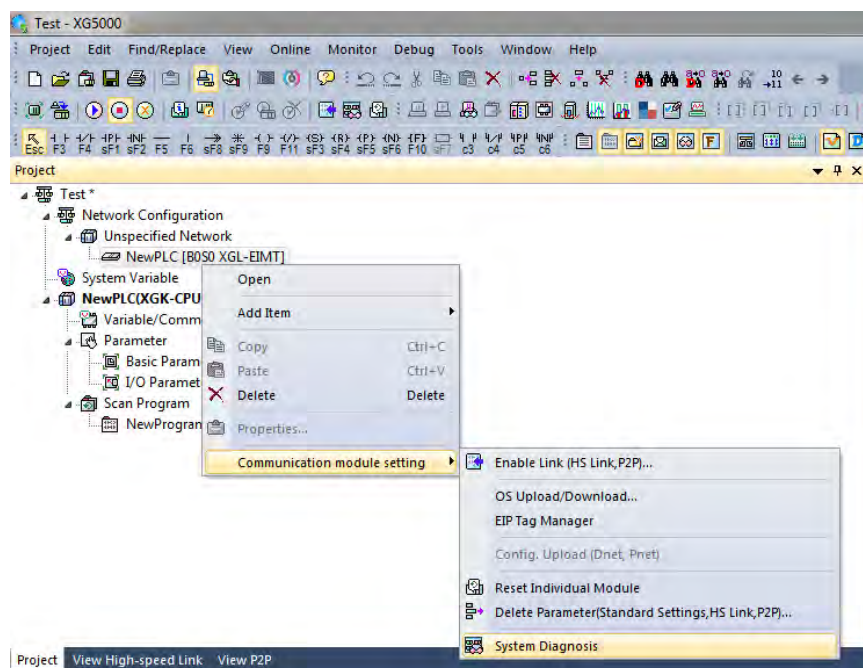

Do a right mouse click after clicking RAPIEnet module (XGL-EIMT/EIMH), and the detailed diagnostics items are displayed. In order to open the system diagnostics screen of an extension base in case RAPIEnet module is installed in the extension base, click the extension base of the system information window to switch to the system diagnostics screen of the extension base.

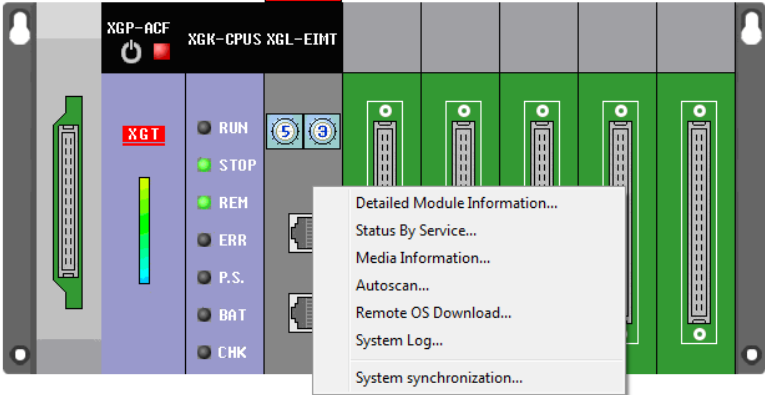

System information	Allocation information - Variable	Comment
Base 0 : XGB-M06A		Main Base(6 Slots)
Power: XGP-ACF		AC100~240V Input
CPU: XGK-CPUS		Standard CPU Module(I/O: Maximum 3,072 Points)
Slot 0: XGL-EIMT	[P00000 ~ P0000F]	RAPIEnet Module, Electrical Master
Slot 1: Empty slot	[P00010 ~ P0001F]	
Slot 2: Empty slot	[P00020 ~ P0002F]	
Slot 3: Empty slot	[P00030 ~ P0003F]	
Slot 4: Empty slot	[P00040 ~ P0004F]	
Slot 5: Empty slot	[P00050 ~ P0005F]	

The meaning of each item on the system diagnostics menu is described below.

(2)

Division	Meaning	Reference
Communication module information	Provides the module information of the master module	-
Service status	Provides the high-speed link/P2P communication information of the master module	-
Media information	Provides the information about communication load (packet volume) of the network	-
Auto Scan	Provides the module information connected to the network	-
Remote O/S Download ¹⁾ (Notice1)	Provides OS download function of the module configured with the master module in network	-
System Log	Provides the information about the abnormality of the master module	-
System synchronization	Provides the module mounted on the base and I/O synchronization function	-

Remarks

Notice1) Remote O/S Download

For a stable operation of the system, Please ask the LS Industrial Systems Service Center as to the Remote O/S Download function.

2) Meanings for each diagnosis item

In order to use the diagnosis item, select the menu you want to check by doing a right mouse click after clicking the RAPIEnet module (XGL-EIMT/EIMH) module.

Communication module information

The module information of the master module is provided in the communication module information.

(1)

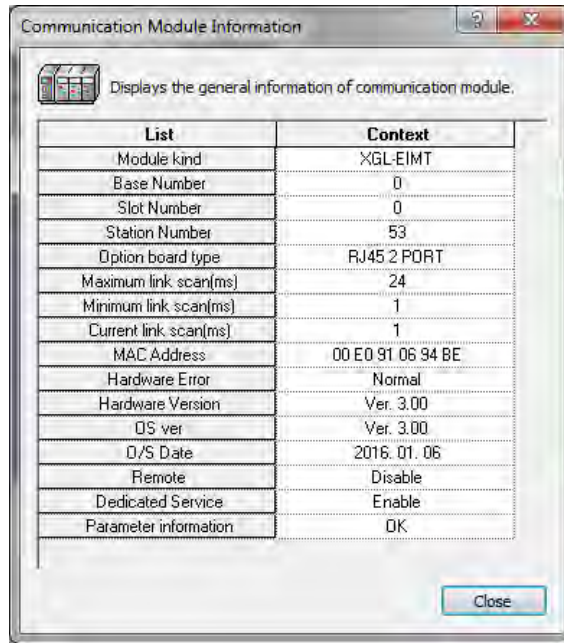

Meanings for each item are as follows.

Items	Sub-items	Contents
Basic information	Communication module type	Displays the type of module: RAPIEnet
	Base number	Displays the base location of the mounted module(0 ~ 7)
	Slot number	Displays the slot location of the mounted module(0 ~ 11)
Link information	Station number	Displays the station number of the module(0 ~ 63)
	Option board type	Communication port type - TP 2 port: Electrical 2 port - HYBRID: Optical 1 port, electrical 1port - FIBER 2 port: Optical 2 port
	Link scan maximum	The maximum task performing time (ms) of OS
	Link scan minimum	The minimum task performing time (ms) of OS
	Link scan current	The current task performing time (ms) of OS
	MAC ADDRESS	Displays MAC address
Hardware / Software information	Hardware error status	Displays hardware status
	Hardware version	Displays hardware version
	OS version	Software version
	OS date	Software date
Communication service type and status	P2P	Displays the status of service performed currently by the module(Enable/Disable)
	High-speed link	
	Remote	Access service information(Enable/Disable)
	Dedicated service	
Parameter information	-	Displays parameter setting status - Display type: Normal, error

Service status

In the service status, you can check the operating status of the high-speed link service and P2P being serviced in the RAPIEnet master module.

In the case of the Smart I/O, since the high-speed link service is used, the service status for each high-speed link block can be checked through the high-speed link service function.

(2)

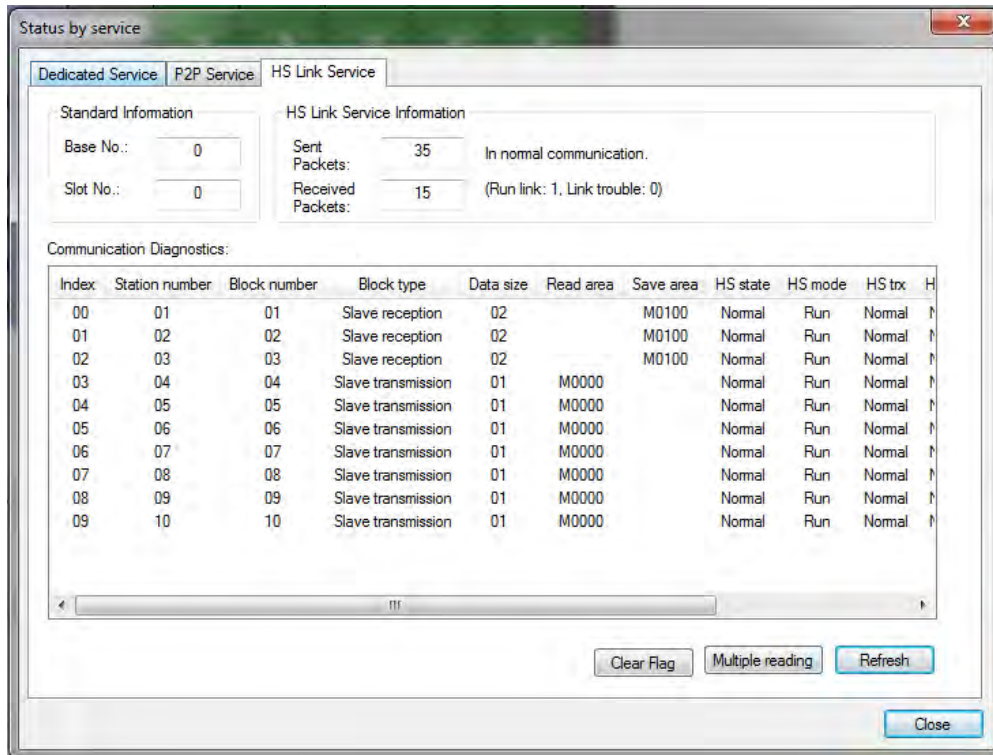

Media information

In the media information, the communication load (packet volume) of the network is provided. Click on the continuous reading of the media information screen, and the status information and packing monitoring contents can be checked in real time, and the information about the packet volume is provided in a graphic form. The meanings for each item are as follows.

(3)

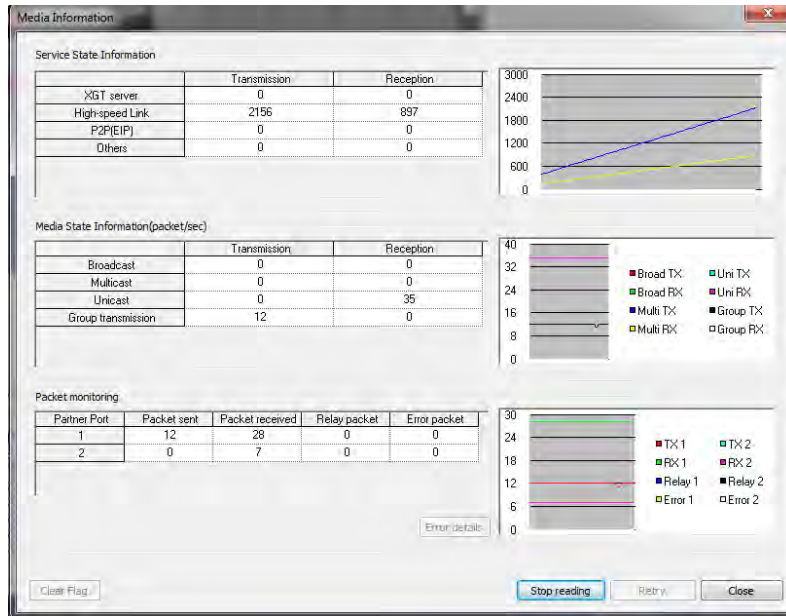

Items	Sub-items	Contents
Service status information	XGT server	The total number of frames to be transmitted and received to the XGT server service
	High-speed link	The total number of frames to be transmitted and received to the high-speed link service
	P2P	The total number of frames to be transmitted and received to the P2P service
	Others	The total number of frames to be transmitted and received to other services
Media status information (packet/second)	Broad cast	The number of packets per second of frames to be transmitted and received to the broadcast
	Multicast	The number of packets per second of frames to be transmitted and received to the multicast
	Unicast	The number of packets per second of frames to be transmitted and received to the unicast
	Group transfer	The number of packets per second of frames to be transmitted and received to the group transfer
Packet monitoring (packet/second)	Transmission	The number of packets per second of frames to be transmitted at each port
	Reception	The number of packets per second of frames to be received at each port
	Relay	The number of packets per second of frames to be relayed at each port
	Error	The number of packets of errors occurring during the transmission and reception at each port
Flag Clear		Initializes the full service count and packet volume
Continuous reading		Provides real-time information about the service status and media status
Redo		Request reading the service status and media status one time
Close		Exits the media information provision

Auto Scan

Auto Scan function provides the system configuration information and information on the module connected to the network. The meanings for each item are as follows.

(4)

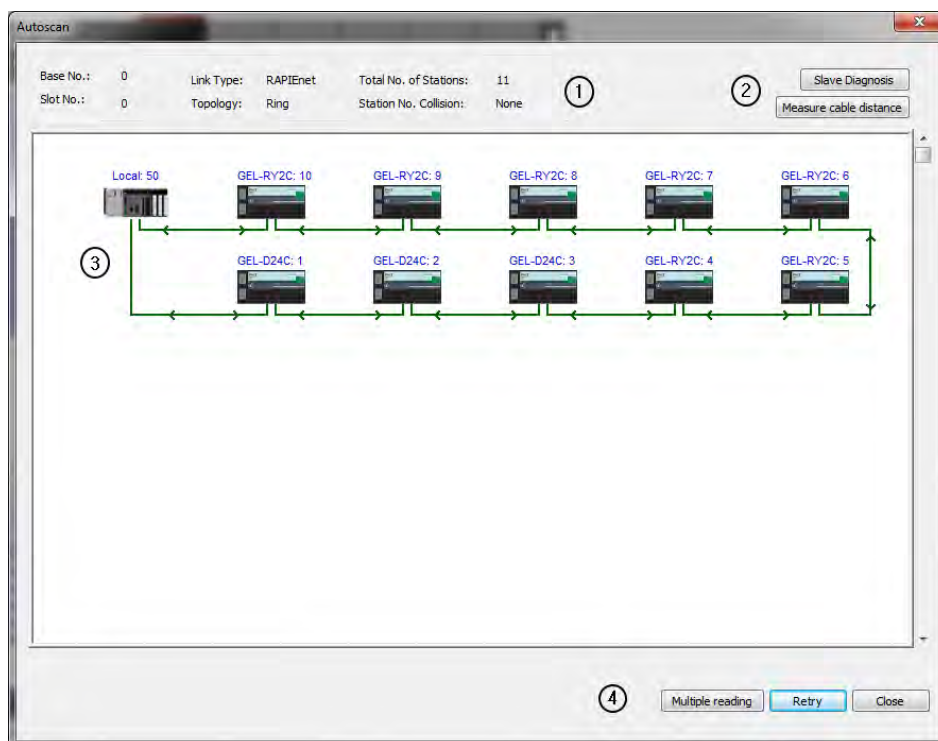

Division	Meaning	Reference
1	System information Provides information about the RAPIEnet system connected to the Local master module* <i>Notice1)</i>	1
2	Slave diagnostics Provide diagnostic information related to the slave. Please refer to the slave diagnostics for details	2
	Cable distance measurement Provides communication distance between modules. However, the cable distance may be measured incorrectly depending on the status of the cable.	-
3	Network configuration screen Displays the current network configuration map	3
4	Continuous reading Provides network configuration information in real time	4
	Redo Request reading the network configuration information one time	-
	Close Exits the Auto Scan service	-

Remarks
 Notice1) Local master module
 It refers to the RAPIEnet module mounted on the PLC connected to XG5000, and the master module that performs the system diagnostics is displayed as a Local master module.

a) Slave diagnostic service

Click the slave diagnostics, and the current slave diagnostic information is provided. The contents by diagnostic information are summarized below.

(a) High-speed link abnormality information provision

In case the high-speed parameter information applied to the RAPIEnet master module connected to XG5000 is different from the information of the Smart I/O that exists in the actual network, the information about the module that does not match is provided after a comparison with the module that exists in the actual network based on the Smart I/O information set in the high-speed link block.

In this case, the provided information is limited to the RAPIEnet master (Local) of the PLC connected to XG5000.

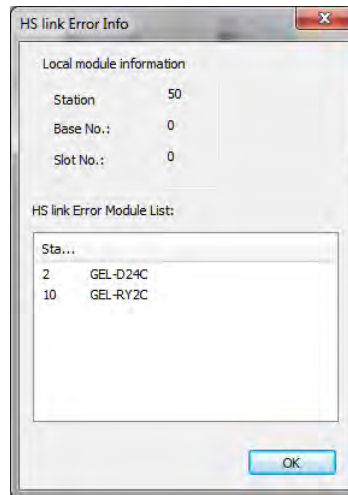

(b) Control group information provision

Click on the slave diagnostics in Auto Scan service, and the slave group^{Notice1)} controlled based on the master module is displayed on the Auto Scan screen. Click each master module displayed on the screen, and the currently controlled slave module is displayed.

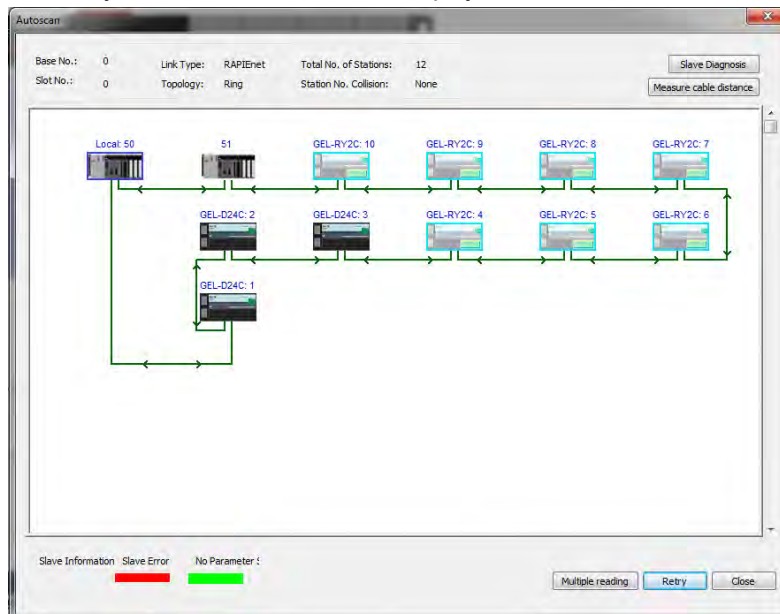

<Example of control group information providing screen:

No. 50 master module controls the GEL-D24C module of No. 1~ 3 station>

(c) Slave status information provision

If Smart I/O module in which parameters are not set or a module where an error occurs exists in the Auto Scan screen, the applicable module is displayed.

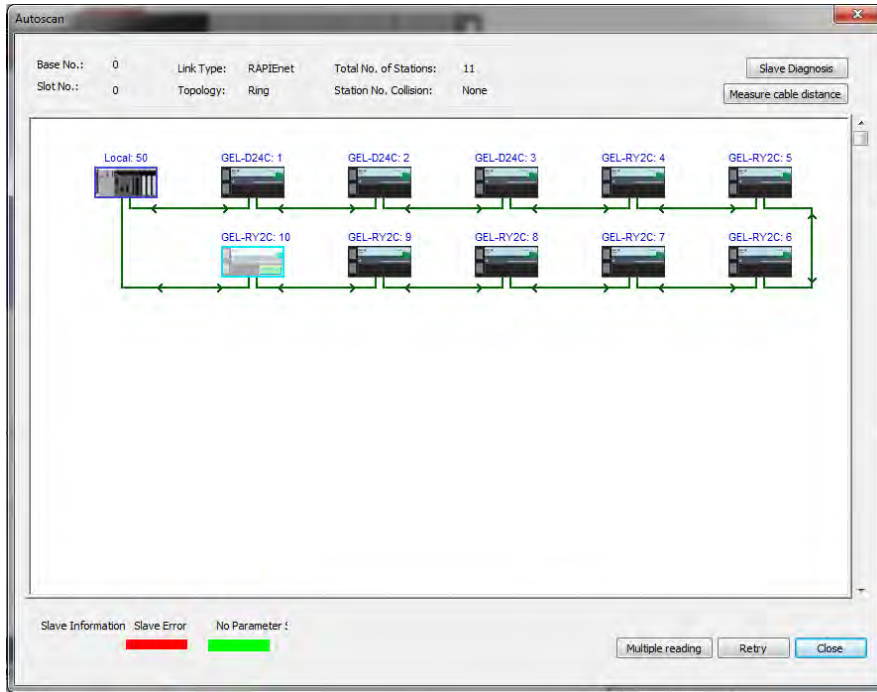

<Example of slave status information: GEL-RY2C of No. 10 station indicates that parameters are not set>

Remarks

Notice1) Slave group

The slave group that appears when you click on the first slave diagnostics displays the Smart I/O module that is controlled from the Local master module.

b) Slave module information

Double click the slave module, except for the Local master module on the Auto Scan screen, the detailed information on each module is provided. The configuration and contents on the slave module information are as follows.

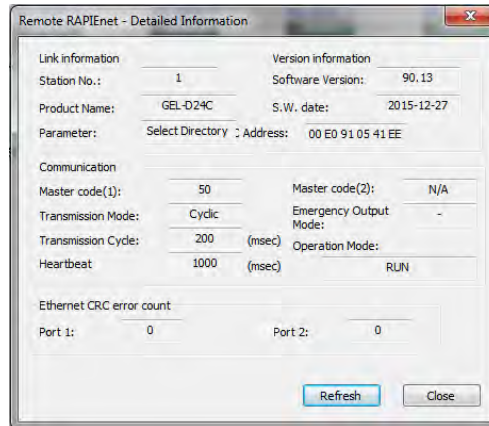

(a) Link information

Division	Contents	Reference
Station No.	Displays the set station No. of Smart I/O	
Product name	Display the module name of Smart I/O	
Parameter	Displays whether to set the parameter of Smart I/O	If the high-speed link is not Enabled, it is displayed as the parameter not set.
MAC address	Displays the set MAC address of Smart I/O	

(b) Version information

Division	Contents	Reference
Software version	Displays O/S version of Smart I/O	
Software date	Displays O/S version of Smart I/O	

(c) Communication information

Division	Contents	Reference
Master station No.(1),(2)	Refers to the number of master station that controls Smart I/O	Master station No. (2) is displayed in case of the master module mounted on XGR
Transmission mode	Means the high-speed transmission cycle of input module	
Transmission cycle	Means the high-speed transmission cycle of output module	
Heartbeat time	Means the set heartbeat value	
Emergency output mode	Displays the set output mode in case of the emergency output of digital output module	
Operation mode	Displays the operating status of Smart I/O	

(d) Ethernet CRC error count

Division	Contents	Reference
Port1, Port2	CRC error counter increases when error frame occurs due to the noise and faulty cable connected to the Ethernet port.	

System log

When a network-related event occurs, system log stores the information in memory area (RAM) and flash area (flash memory of the master module) and provides the system log information.

In the case of flash area log, the log of memory area is stored in the flash area if you press LOG switch in the front side of the module.

(5)

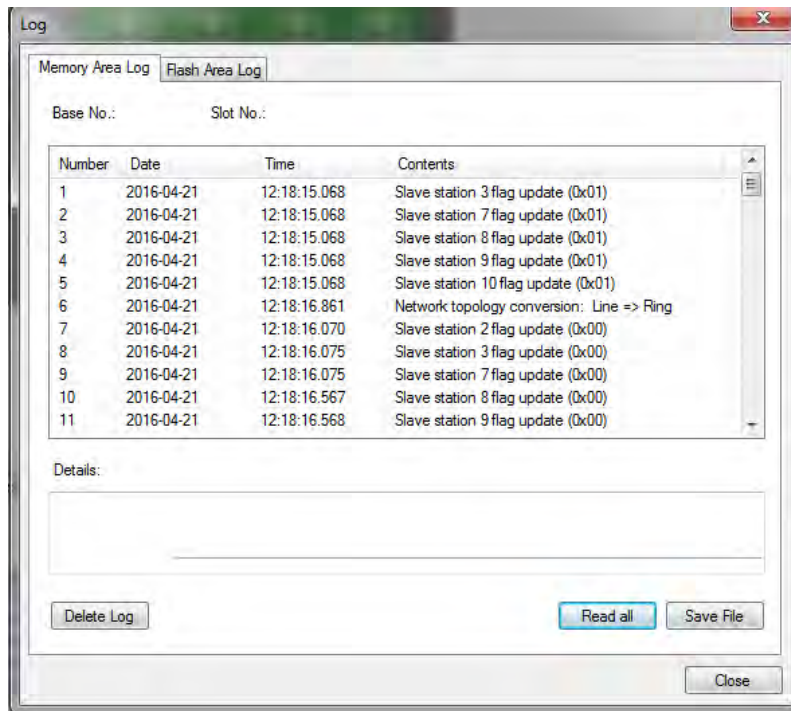

<Example of system log >

(6)

System synchronization

(7) System synchronization function is a service that provides the module mounted on the base and I/O synchronization function.

Diagnostic area

Diagnostic area use function is to transmit the diagnostic information provided by the slave module to the PLC device area. Check the diagnostic area use and enter the start address of the PLC device in which the diagnostic information is to be stored, the diagnostic area of one word per slave is automatically allocated to the high-speed link block.

The diagnostic information provided by the diagnostic area is as follows, and the operation bit is changed to 1 when the problem occurs.

Operation Modes	Operation Conditions	Operation Bit
Heartbit error	Heartbit error occured	Bit 0
Ethernet CRC Error Count(Port 1)	CRC error occured of Port1	Bit 1
Ethernet CRC Error Count(Port 2)	CRC error occured of Port2	Bit 2

11.5.2 H/W Diagnostic Functions

H/W diagnostic function provides a self-diagnostic function. A user can check the LED status and hardware abnormality of the communication port through the self-diagnostic function.

1) Communication port diagnostic function

Communication port diagnostic function is a service that provides the information about hardware abnormality of the communication port. If the communication is not normally made even when the apparent problem is not found after the installation of the product, the hardware abnormality can be determined through the service. The procedures are as follows.

Station number settings

Power is provided after the station number is set to 92.

Cable connection

Both ends of the communication cable are connected to Port 1 and Port 2 as shown in the figure below.

(1)

(2)

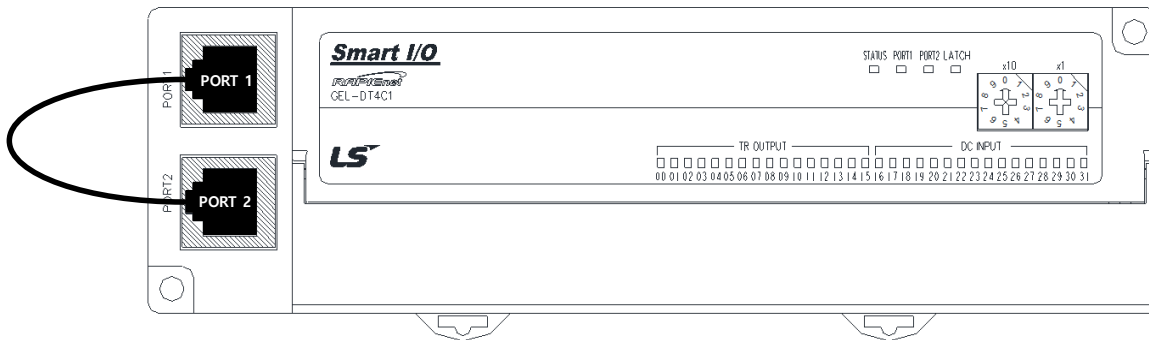

(3)

LED status

1) When the station number switch is set to 92, Smart I/O module LED is subject to the following conditions.

Division	LED mode	Meaning	Remarks	
STATUS	Green	Blinking	Displays self-test in progress	STATUS
	Red	Lighting	Error between communication ports occurs(RJ-45 ↔PHY IC)	
PORT1/2	Green	Lighting	Completes physical connection of the port	PORT1/2
	Red	Blinking	Proceeds with communication through the port	

2) When the station number switch is set to 93, Smart I/O module LED is subject to the following conditions.

Division	LED mode	Meaning	Remarks	
STATUS	Green	Blinking	Displays self test in progress	STATUS
	Red	Lighting	PHY IC error occurs	
PORT1/2	Green	Lighting	Completes physical connection of the port	PORT1/2
	Red	Blinking	Proceeds with communication through the port	

3) When the station number switch is set to 94, Smart I/O module LED is subject to the following conditions.

Division	LED mode	Meaning	Remarks	
STATUS	Green	Blinking	Displays self test in progress	STATUS
	Red	Lighting	Error in the Ethernet part inside ASIC occur	
PORT1/2	Green	Lighting	Completes physical connection of the port	PORT1/2
	Red	Blinking	Proceeds with communication through the port	

2) LED diagnostic function

LED diagnostic function is a service that provides the information about the operating mode of LED (STATUS, PORT1, PORT2, LATCH) that displays the operating status of Smart I/O.

Station number settings

Power is provided after the station number is set to 96-99.

Cable connection

Both ends of the communication cable are connected to Port 1 and Port 2 as shown in the figure below.

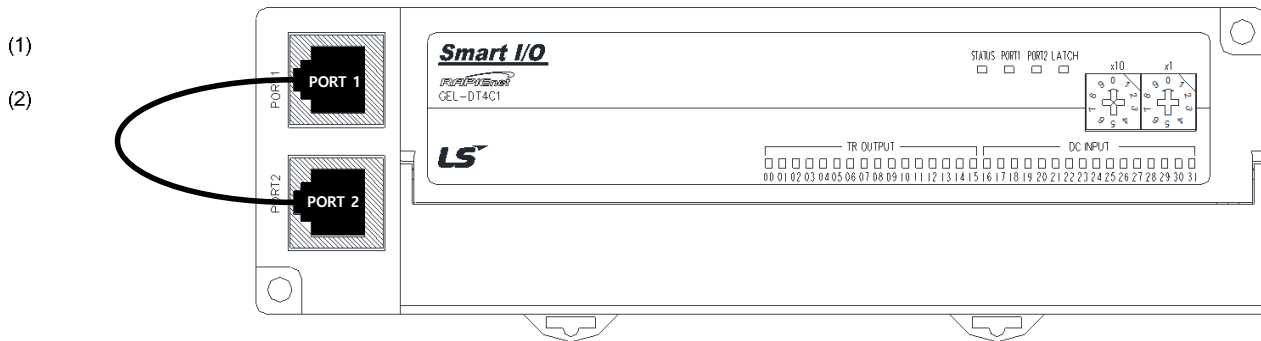

LED status

(3) Check hardware status through LED operating mode.

Classification		Normal	Abnormal	Reference
STATUS	Green	Fliker	On, Maintain Off	-
	Red	Fliker	On, Maintain Off	-
PORT1	Green	On	Maintain Off	-
	Red	Fliker	On, Maintain Off	-
PORT2	Green	On	Maintain Off	-
	Red	Fliker	On, Maintain Off	-
LATCH	Green	Fliker	On, Maintain Off	Only for GEL-DT4C1/TR4C1
	Red	Fliker	On, Maintain Off	

Chapter 12 Installation and Wiring

12.1 Installation

12.1.1 Installation Environment

This machine has a high reliability regardless of the environment to install. But cares should be taken to secure the reliability and the safety as follows.

1) Environment Condition

- (1) Install it to a water-proof and dust-proof control panel.
- (2) Do not apply continuous impact or vibration.
- (3) Do not expose it directly to direct rays.
- (4) No dew by sudden change of temperature.
- (5) Do not exceed surrounding temperature 0~55°C.
- (6) Do not exceed relative humidity 5 ~ 95% .
- (7) No corrosive gas or combustible gas.

2) Installation Construction

- (1) When working the screw hole and the wiring, it is not allowed to put the wire remnants into the PLC.
- (2) The installation location should be the place to operate.
- (3) Do not install it on the same panel as the high voltage machine.
- (4) The distance between wiring duct and the surrounding module should be at least 50mm apart.
- (5) The grounding should be done on a good place free from noise.

3) Radiation Design of Control Panel

- (1) When installing the PLC in the sealed control panel, the radiation design should be done considering the radiation of other machine as well as the radiation of PLC itself. When circulating the air using the vent or the general fan, it may effect the PLC system due to the inflow of gas or dust.
- (2) It is recommended to install the filter or use the sealed type thermal exchanger.

12.1.2 Notices in installing Profibus-DP module

Profibus-DP Smart I/O can set max. 126 stations. (including master)

- (1) Check the basic factors necessary for the system configuration and select the proper communication module.
- (2) Prepare the cable and accessories such as tab, terminal resistance etc. to be used for this communication.
- (3) The station no. of all other stations including this module should be different. If connecting with double station no., it may cause the communication error.
- (4) In case of operating with normal communication, the mode switch of master module should be at RUN mode. If changing the mode switch of master module in the status that other stations are in communication, it may cause significant communication obstacle with other stations. So, special cares are needed.
- (5) For communication cable, the designated standard cable should be used. If not, it may cause significant communication obstacle.
- (6) Check if the communication cable is cut off or short-circuited before installation.
- (7) Tighten the communication cable connector completely and fix the cable connection tightly. If cable connection is not complete, it may cause significant communication obstacle.
- (8) If the communication cable is twisted or the cable is not connected properly, it may cause communication error.
- (9) In case of connecting the long distance communication cable, the wiring should be done far from the power line or inductive noise.
- (10) If LED action is abnormal, check the trouble causes referring to this manual Chapter 12. "Trouble Shooting". If the problem repeats after taking the action, contact customer service center.
- (11) Install this communication module in the status that PLC power is 'OFF'.
- (12) After finishing the communication cable connection, put the power ON and check the normal action in the LED action status. If it is normal, download the corresponding program into GMWIN for GLOFA series and into KGLWIN for MASTER-K series and run the program.

12.1.3 Notices in installing DeviceNet module

DeviceNet Smart I/O can set max. 64 stations(one master module included).

- (1) Check the basic factors necessary for the system configuration and select the proper communication module.
- (2) Prepare the cable and accessories such as tab, terminal resistance etc. to be used for this communication.
- (3) It is available to control the speed automatically in accordance with the communication speed of master module by the means of Auto baudrate function and it is required to comply the cable specification.
- (4) In case of using the tab, it is required to use terminal resistance on both side of the tab. In case of single network system, set it not to repeat the station no. Install the master module in the base with the PLC power Off and set the communication address and communication speed accurately.
- (5) Check if the connector pin of this communication module is normal and make sure that the power cable and the communication cable are not short-circuited.
- (6) If using the combined module (GDL-DT4A) when setting the *high speed link* parameter of G4/6L-DUEA, the module will occupy 2 registration lists and it is available to register max. 31 (but only GDL-DT4A is installed). If using XGL-DMEA module, the module is available to register max. 63 stations.
- (7) The communication speed to be used for this communication module is 125K, 250K, 500Kbps and when changing the communication speed after setting the communication speed, turn power 'Off' and change the communication setting switch and then apply the power 'On'. Then the changed mode shall be applied.

Communication speed parameter is downloaded from SyCon after resetting and turn the power On.

1) Materials required in installation

Required material	Dnet I/F module
Communication cable	Thick cable/Thin cable
Tab/terminal resistance	4/8 port tab, terminal resistance:121Ω, 1%, 1/4W
24V power supply device	General power supply
Connection connector	5 pin open type connector

2) Notices in installing the Connector

The following cares should be taken before installing the connector.

- (1) Deal the connector when the signal is not loaded in the cable.
- (2) If the module installed in the system is in action, stop the action and then install it.
- (3) If the power is supplied, the power should be 'Off' before working.
- (4) After completing the installation, tighten the corresponding cable completely not to be shaken or removed.
- (5) Install for cable signal line to be connected with conductor of connector.

3) How to install the connector

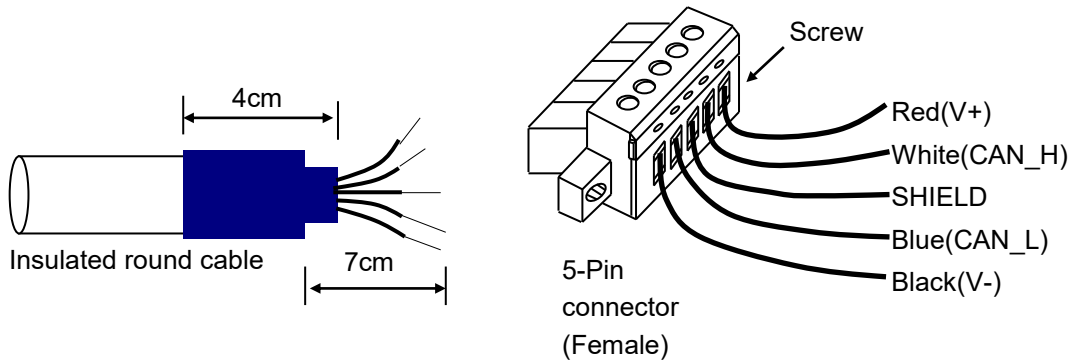

- (1) Peel off the cover of the cable approx. 7cm for cable connection.
- (2) Remove the covered net covering the signal cable and remove the aluminum foil covering the signal cable and the power cable.
- (3) Cut the shrinkage cover for packing approx. 4cm and wrap the cable and then cover the exposed conductor and insulated coverings of the cable.
- (4) Peel off the coverings of the signal cable and the power cable approx. 3mm from the ends.
(For safe cabling, apply heat to the compressed cover for packing and stick to the cable closely.)

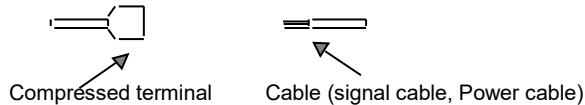

- (5) After inserting the peeled coverings into the clamp screw of the connector, tighten the screw. (Cares should be taken to match the cable with the signal name of the connector.)

There are 2 ways of cable connection : one way to use the tab as below and another way to connect by the drop method. DC 24V power should be installed in the place necessary to maintain the voltage when Smart I/O module is getting more or the cable is getting longer.

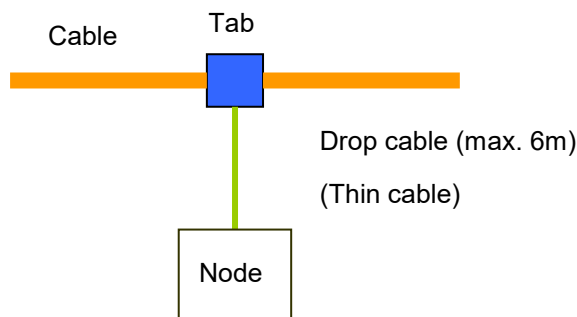

The method to connect the network is as follows.

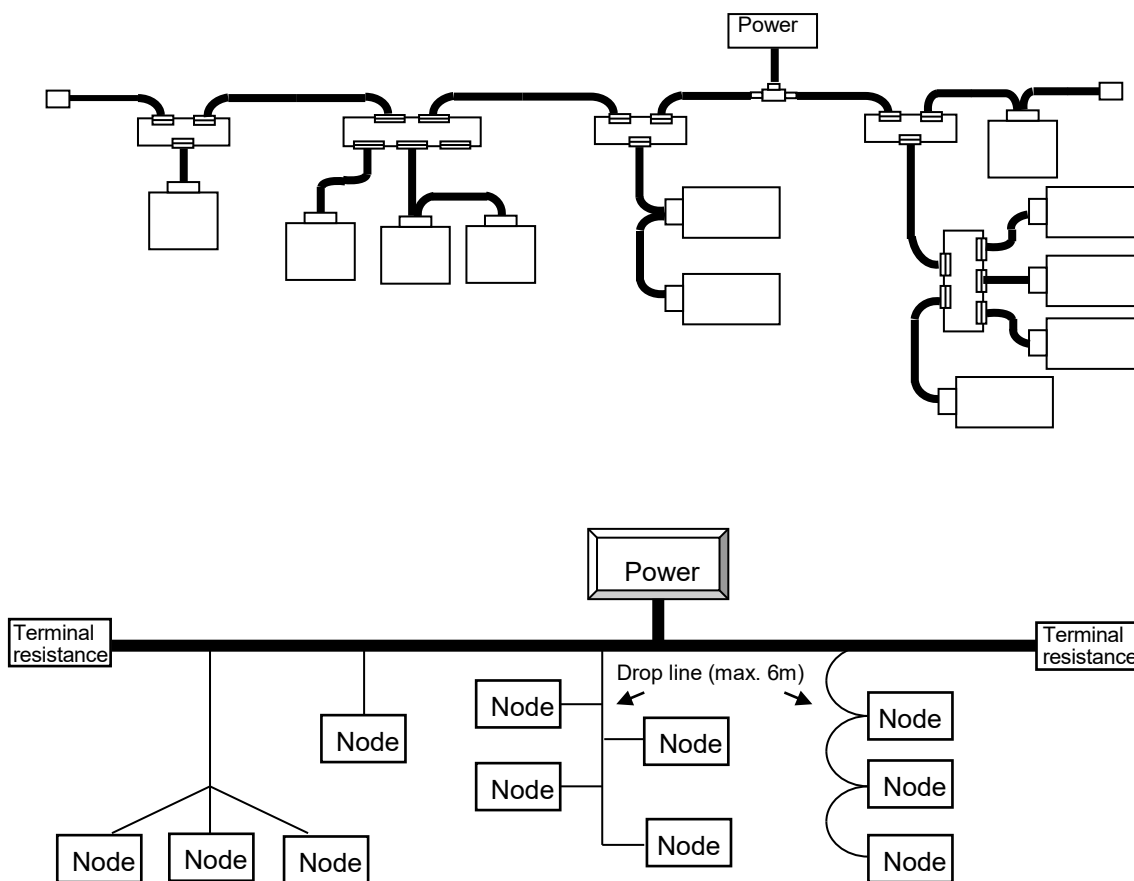

Max. distance of Network: Max. distance of node and terminal resistance

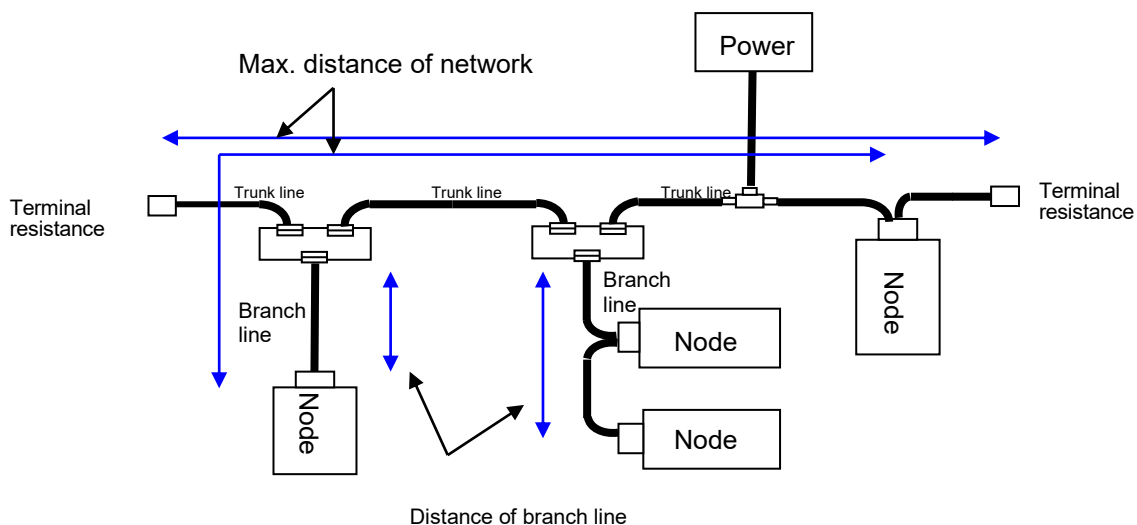

Distance of brunch line: Distance from first branch line of trunk line to the end of brunch line (Max. 6m)

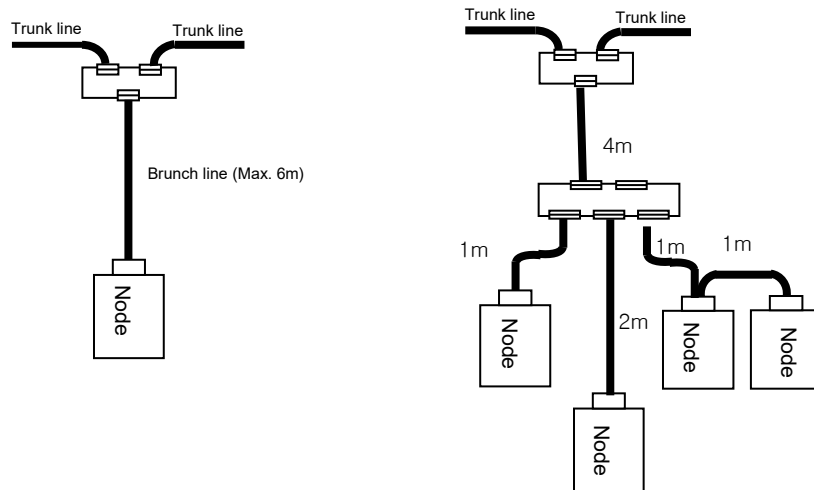

4) How to install the tab (Example of 8-Port tab)

It is available to connect to the trunk line of device port tab and connect or remove max. 8 port tab.

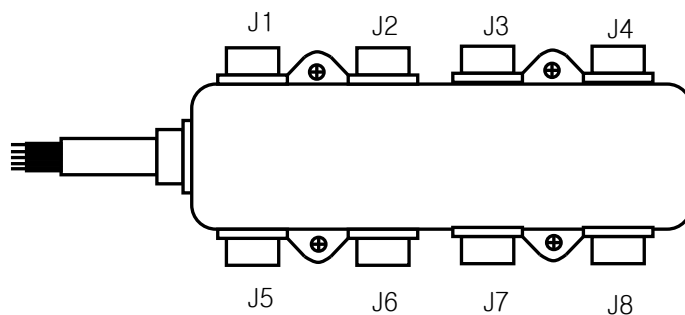

- (1) The drop line composed of Thick cable or Thin cable is available to connect to the device by the tab and in case of Open-style tab, it is available to use 3 types of connectors.
 - Pluggable screw type
 - Hard-wired screw type
 - Soldered type
- (2) For the cable connection, it is ideal to connect the drop line when the system does not act. If connecting when cable system is acting, it is required to connect to the trunk line after checking the connection status with other devices not to influence the communication.

(3) If connecting to the trunk line, it is required not to exceed max. allowable length.

Network max. distance according to the cable type is as follows.

Cable type	Network max. distance
THICK cable	500 m
THIN cable	100 m

Network max. distance according to the communication speed is as follows.

Communication speed	Network max. distance
500 Kbps	$L_{THICK} + L_{THIN} \leq 100 \text{ m}$
250 Kbps	$L_{THICK} + 2.5 * L_{THIN} \leq 250 \text{ m}$
125 Kbps	$L_{THICK} + 5 * L_{THIN} \leq 500 \text{ m}$

LTHICK:THICK cable length (max.8A), LTHIN:THIN cable length (max.3A)

Communication speed	Network max. distance	
	THICK cable length	THIN cable length
500 Kbps	Less than 100 m	Less than 100 m
250 Kbps	Less than 250 m	
125 Kbps	Less than 500 m	

If the communication speed is 500Kbps, the length of branch line is less than 6m and total distance of branch line is less than 39m. And if the communication speed is 250Kbps, the length of branch line is less than 6m and total distance of branch line is less than 78m and if the communication speed is 125Kbps, the distance of branch line is less than 6m and total distance of branch line is less than 156m respectively.

5) Power Layout

The layout of the power is as follows.

(1) In case of arranging the node on both side of the power,

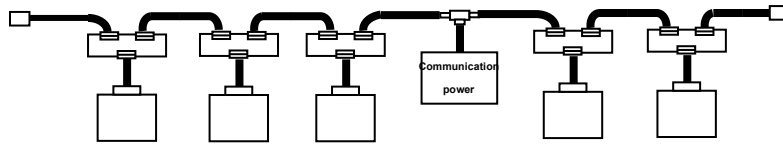

(2) In case of arranging the node on one side,

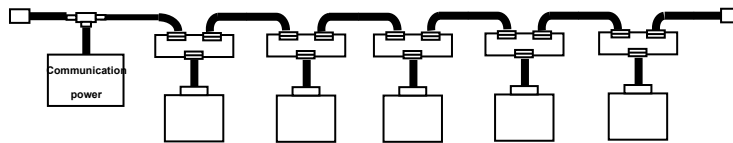

(3) In case of installing double power and dividing the power supply system,

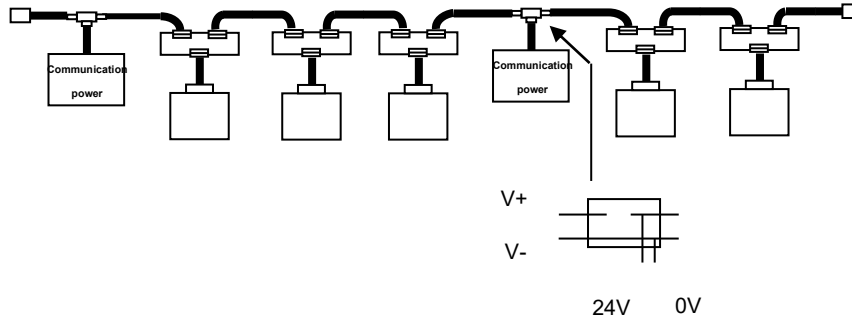

(4) In case of duplication of the power

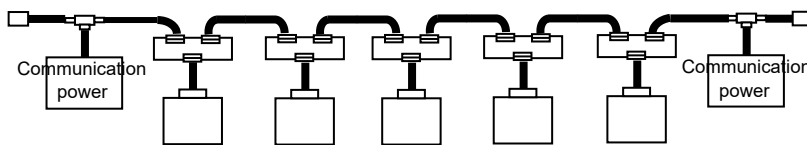

The distance between the power and the power tab shall be within 3m.

12.1.4 Notices in installing Rnet module

Rnet Smart I/O can set max. 64 stations(one master module included).

- (1) The station no. of all other stations including this module should be different. If connecting with double station no., it may cause communication error.
- (2) In case of operating with normal communication, the mode switch of master module should be at RUN mode. If changing the mode switch of master module in the status in which other stations are in communication, it may cause significant communication obstacle with other stations. So, special cares are needed.
- (3) For communication cable, the designated standard cable should be used. If not, it may cause significant communication obstacle.
- (4) Check if the communication cable is cut off or short-circuited before installation.
- (5) Tighten the communication cable connector completely and fix the cable connection tightly. If cable connection is not complete, it may cause significant communication obstacle.
- (6) If the communication cable is twisted or the cable is not connected properly, it may cause communication error.
- (7) If using the combined module (GRL-DT4A) when setting *high speed link* parameter, the module will occupy 2 registration lists and it is available to register max. 31 (but only GRL-DT4A is installed).
- (8) In case of connecting the long distance communication cable, the wiring should be done far from the power line or inductive noise.
- (9) The (twisted pair) shielded cable of communication cable should be connected with the body of 9 Pin connector on both side.
- (10) If LED action is abnormal, check the trouble causes referring to this manual Chapter 12.'Trouble Shooting'. If the problem repeats after taking the action, contact to A/S center.
- (11) Install this communication module in the status that PLC power is 'OFF'.
- (12) After finishing the communication cable connection, apply the power ON and check the normal action in the LED action status. If it is normal, download the corresponding program into GMWIN for GLOFA series and into KGLWIN for MASTER-K series and run the program.

12.1.5 Notices in installing Modbus module

Modbus Smart I/O can set max. 32 stations.

- (1) The user must select the action mode for Cnet I/F module correctly and set the action mode accordingly. If setting the action mode wrong, it may cause communication error.
- (2) For the channel using the exclusive communication mode, it is required to set the station no. In case of the system using the exclusive communication mode and communicating by RS-422/485, it is not allowed to have Modbus module of the same station no. in the same network. In case of RS-422 communication, if there is double station no., it may cause communication error.
- (3) For communication cable, the designated standard cable should be used. If not, it may cause significant communication obstacle.
- (4) Check if the communication cable is cut off or short-circuited before installation.
- (5) Tighten the communication cable connector completely and fix the cable connection tightly. If cable connection is not complete, it may cause significant communication obstacle.
- (6) RS-422/485 cable should connect the TX/RX correctly. When several stations are connected, the first 2 stations should be connected by TX and RX and other stations should be connected by TX to TX and RX to RX themselves. (RS-422 communication)
- (7) In case of RS-485 communication, TX and RX of Cnet I/F module should be connected to each other.
- (8) If the communication cable is twisted or the cable is not connected properly, it may cause communication error.
- (9) In case of connecting the long distance communication cable, the wiring should be separated far from the power line or inductive noise and if necessary, it should be covered.
- (10) If LED action is abnormal, check the trouble causes referring to this manual "Chapter 12. Trouble Shooting". If the problem repeats after taking the action, contact Customer service center.

12.1.6 Notices in Handling

Here it describes notices in handling from the opening of each unit and module to the installation.

- Do not drop or apply the strong impact.
- Do not remove the PCB from the case. It may cause failure.
- Cares should be taken not to make foreign materials such as the wire remnants etc. enter the unit when wiring. If entered, remove them before applying power.

1) Notices in handling the product

Here it describes the notices in handling and installing the basic unit and the extended module.

(1) Recheck the I/O standard specification

Input part should pay attention to the input voltage and in case of output part, if applying the voltage exceeding max. capacity to Open/Close, it may cause failure, breakage and fire.

(2) Use Wire

The wire should be selected considering the ambient temperature, allowable current and the min. spec. of the wire should be more than AWG24(0.18mm²).

(3) Environment

When I/O wiring, if it is close to heat generating machine or material or if the wiring is contacted directly to oil for long time, it may cause short-circuit, breakage and failure.

(4) Polarity

Check the polarity before applying power to the terminal block that has the polarity. Special cares should be taken not to wire AC input power to DC24V external power supply terminal on the edge of basic unit input part. In case of DeviceNet, 24V power enters into the communication cable together and it is not necessary to wire separately.

(5) Wiring

- When wiring the I/O line with high voltage cable and the power cable together, induction obstacle occurs which may cause the failure and malfunction.
- It is not allowed to pass the cable in front of I/O action indication part (LED). (because it prevents from distinguishing the I/O indication.)
- In case the inductive load is connected to the output part, please connect the surge killer or diode to the load in parallel. Connect the cathode of diode to the '+' side of the power.

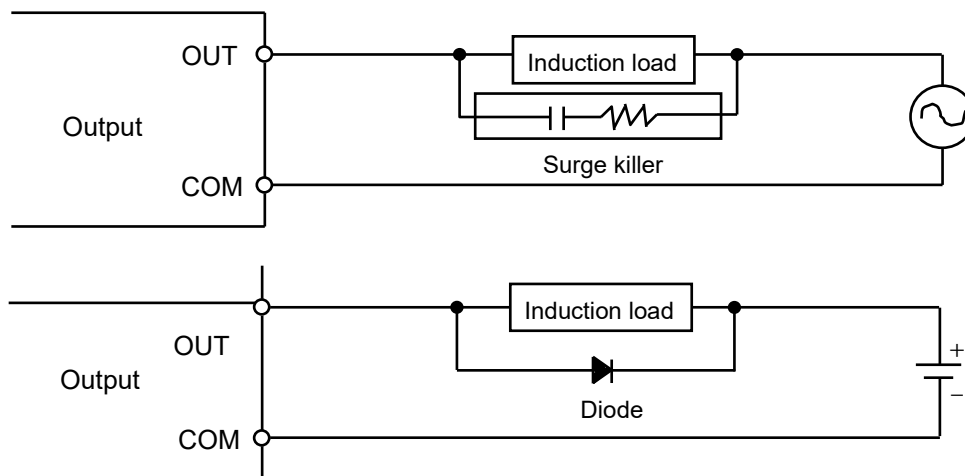

(6) Terminal block

When wiring terminal block or making screw hole, care should be taken not to make the wire remnants enter the PLC. It may cause malfunction and failure.

(7) Except for the mentioned above, do not apply strong impact to the basic or extended unit or remove the PCB from the case.

2) Notices in installation

Here it describes the notices in attaching the PLC to the control panel.

(1) Sufficient distance is required to have well-ventilated room and facilitate the exchange of the basic unit and the extended module. Especially, for the periodical exchange of battery (3 years), please separate the left side of the basic unit and the control panel for at least 100mm.

(2) For the max. radiation effect, it is required to install it as shown on the figure below.

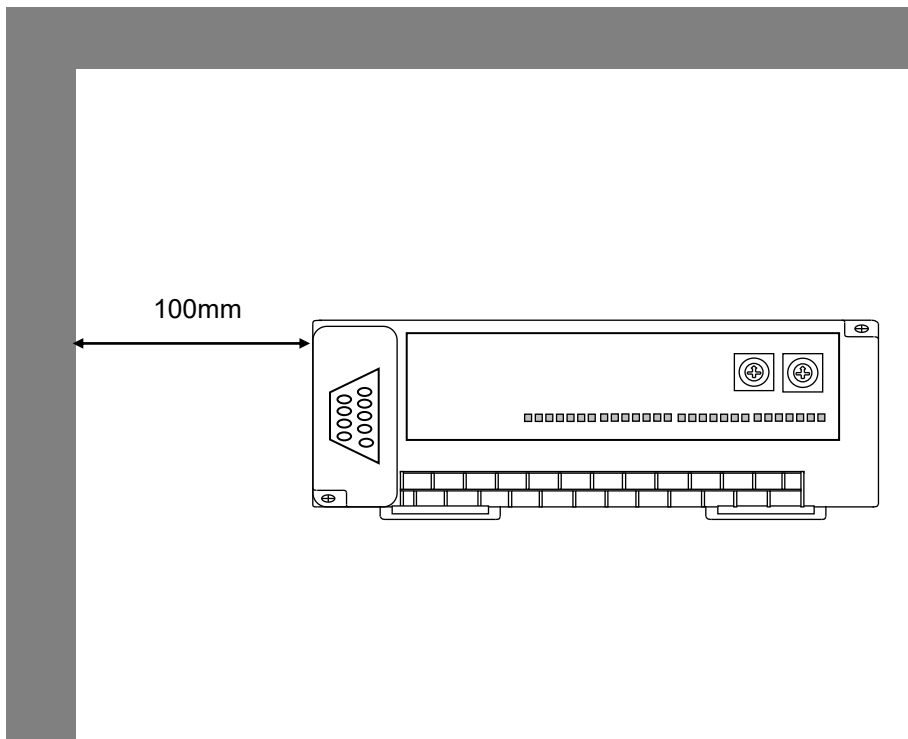

(3) Use different panel for large sized electronic contactor or vibration source such as no-fuse breaker etc. and install separately.

(4) Install the duct for wiring if necessary.

But, if the dimension of upper part or lower part of PLC is smaller than the figure below, please pay attention to the following.

- In case of installing on the upper PLC, the height of wiring duct should be less than 50mm for good ventilation.
- In case of installing on the lower PLC, please consider minimum radius of the cable.

(5) In case the equipment is installed in front of the PLC (inside the door) to avoid the effect of radiant noise or the heat, it is required to separate it more than 100mm and be install.

And the left/right direction of the unit and the equipment should be separated more than 100mm and installed.

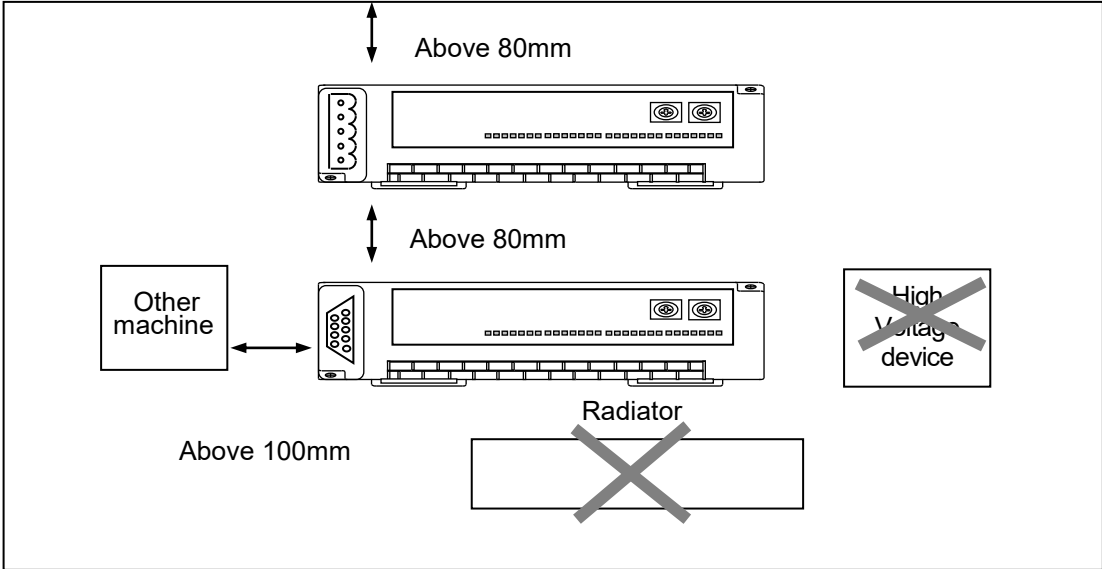

PLC Attaching

(6) As Smart I/O is installed with Hook for DIN rail (rail width 35mm), it is available to attach the DIN rail.

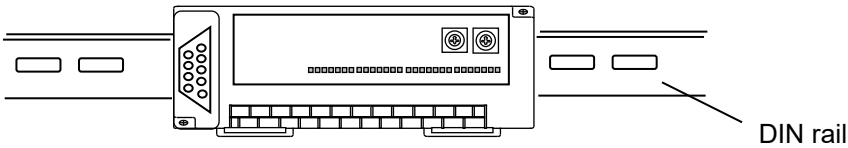

12.2 Wiring

Here it describes the notices related to the wiring in case of using the system..

12.2.1 Power Wiring

- 1) For power, please use DC 24V power supply.
- 2) If the power variation is larger than the regular range, please connect a constant voltage transformer.
- 3) In order to prevent the noise from the power cable, it is required to twist the power cable densely if possible, and connect within the shortest distance.

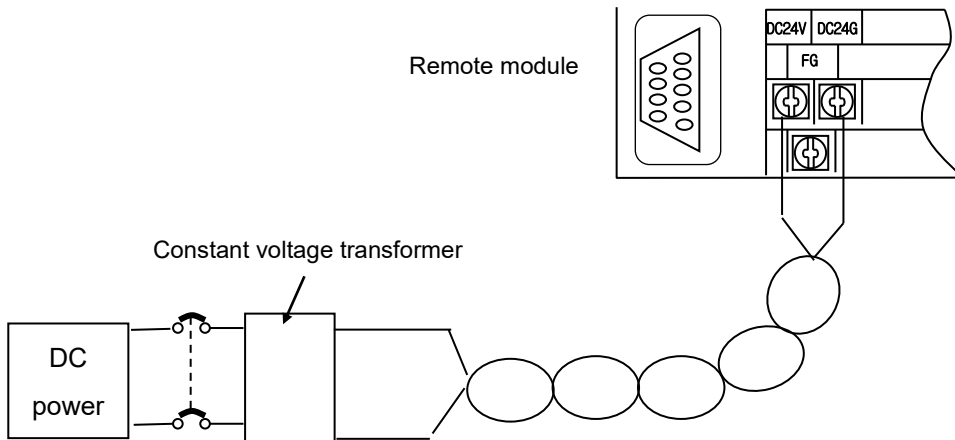

- 4) Connect power of which the noise between lines or between grounds is small.
(if there is much noise, please connect the insulation transformer.)

- 5) For PLC power, I/O machine and power machine, it is required to divide the system as follows.

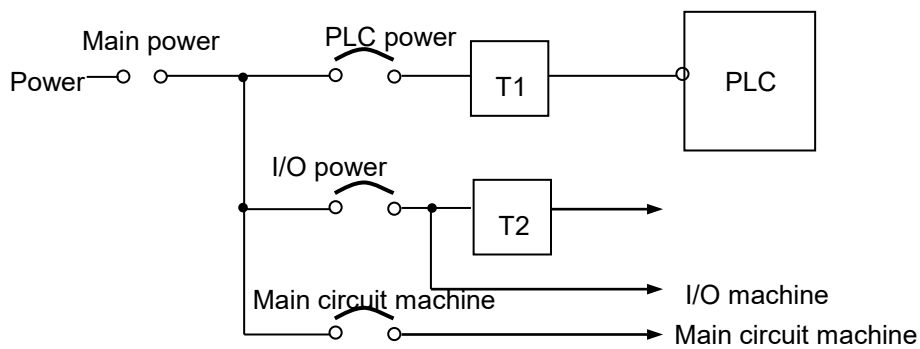

※ T1,T2: Constant voltage transformer

- 6) For the power cable, it is required to use a thick one (2mm²) to make the small falling down of the voltage.
- 7) Smart I/O can be abnormal status by cable voltage drop of power cable when many Smart I/O products are installed on a pair of power cable.
- 8) The power DC24V cable is not allowed to approach closely to the main circuit (high voltage, convection current) cable, I/O signal cable and needs to separate more than 80mm apart.
- 9) Please use the surge absorber to prevent the lightning as shown on the below.

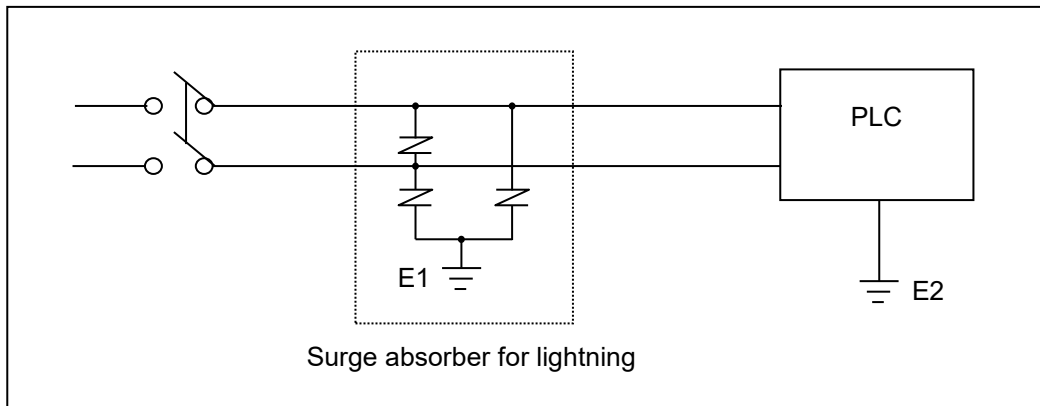

Remark

- 1) Separate the earth (E1) of the surge absorber for lightning and the earth (E2) of PLC.
- 2) Select the surge absorber for lightning so that it does not exceed max. allowable voltage of the absorber even when the power voltage is rising maximum.

- 10) When you are afraid of the invasion of the noise, please use the insulation sealed transformer or the noise filter.
- 11) In case of the wiring of each input resource, the wiring of the sealed transformer or the wiring of the noise filter is not allowed to pass the duct.

12.2.2 I/O Device Wiring

- 1) The spec. of I/O wiring cable is 0.18~2 mm² and it is recommended to use the cable spec. (0.5mm²) conveniently.
- 2) Input cable and output cable should be separated for wiring.
- 3) I/O signal cable should be separated at least 80mm from main circuit cable of high voltage, high current when wiring.
- 4) In case it is not available to separate the main circuit cable and the power cable, please use the shielded cable and earth the PLC.

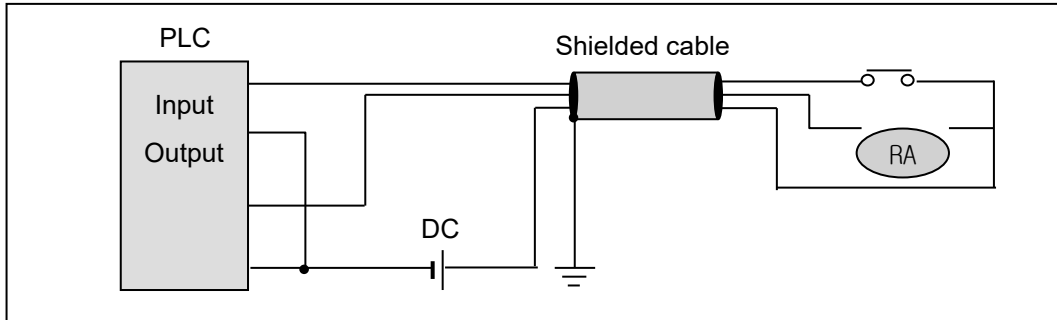

- 5) In case of pipe wiring, make sure of the pipe and then ground it.
- 6) DC24V output cable should be separated from AC110V cable and AC220V cable.
- 7) In case of wiring the long distance more than 200m, the error occurs according to the leakage current caused by the interline capacity.

12.2.3 Grounding Wiring

- 1) As this PLC carries out sufficient noise policy, it is available to use without grounding except the case where there is much noise. But, when grounding, please refer to the following notices.
- 2) When grounding, please use the exclusive grounding if possible.
For the grounding construction, please use the 3rd class grounding (grounding resistance less than 80 Ω).
- 3) If not available to use the exclusive grounding, please use the common grounding as shown on the figure (B).

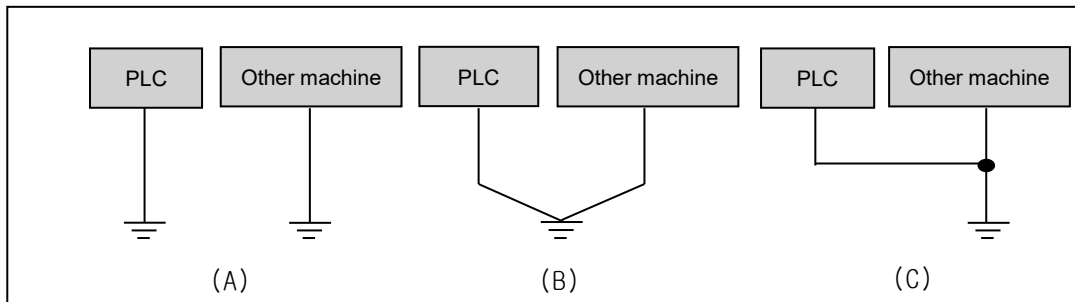

- (A) exclusive grounding: Excellent (B) common grounding: Good
 (C) common grounding : Bad

- 4) Please use the electric wire for grounding more than 2 mm² . Place the grounding point near this PLC if possible and shorten the length of the grounding cable.

▶ When connecting the extended base, please connect the extended connector accurately.

- ▶ Do not remove the PCB from the module case and modify the module.
- ▶ When attaching/removing the module, the power should be OFF.
- ▶ Use the cellular phone or radio phone apart more than 30mm from the product.
- ▶ I/O signal cable and communication cable should be at least 10cm apart from the high voltage cable or the power cable to avoid the effect caused by the noise or the change of magnetic field.

12.2.4 Cable Specification for Wiring

The Cable specification to be used for the wiring is as follows.

External connection type	Cable spec.(mm ²)	
	Low limit	High limit
Digital input	0.18 (AWG24)	1.5 (AWG16)
Digital output	0.18 (AWG24)	2.0 (AWG14)
Analog I/O	0.18 (AWG24)	1.5 (AWG16)
Communication	0.18 (AWG24)	1.5 (AWG16)
Main power resource	1.5 (AWG16)	2.5 (AWG12)
Protection grounding	1.5 (AWG16)	2.5 (AWG12)

For the power and I/O wiring for Smart I/O, it is required to use the compressed terminal.

- Use 'M3' type screw for the terminal.
- Tighten the terminal screw with 6 ~ 9 kg · cm torque.
- Use the fork type screw for the compressed terminal.

Example of the proper compressed terminal (fork type)

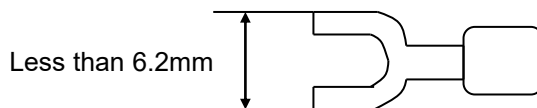

Chapter 13 Maintenance and Repair

To maintain the PLC in optimal status, please carry out daily check and regular check.

13.1 Repair and Check

I/O module is usually composed of semiconductor microelectronic device and the life is semi-permanent. As the microelectronic device may occur the error caused by the ambient environment, it is required to check it periodically. The following are items to be checked 1~2 times every 6 months.

Check items		Judgment basis	Action
Ambient environment	Temperature	0 ~ +55°C	Control the use temperature and the use humidity.
	Humidity	5 ~ 95%RH	
	Vibration	No vibration	Use the dust-proof rubber or take the vibration protection policy.
Shaking of each unit and module		No shake	Make all unit and module not to be shaker
Terminal screw loosened.		No loosening	Tighten the loosened screw.
Input voltage change rate		Within -15%/+10%	Maintain the change rate within the allowable range.
Spare parts		Check if the quantity of spare part and the preservation status is good.	Make up insufficient and improve the preservation status.

13.2 Daily Check

Daily checking point for Smart I/O module is as follows.

1) Daily check for Profibus-DP module

Checking items		Description	Judgment basis	Action
Cable connection status		Cable loosening	No loosening	Tighten the cable
Module connection status		Screw loosening	No loosening	Tighten the module screw.
Indication LED	RUN LED	Light 'ON' check	Steady-state of Power	Refer to Chapter 3.
	RDY LED	Light 'ON' check	Steady-state of communication module interface	Refer to Chapter 3.
	ERR LED	Light 'ON' check	Abnormal communication H/W or cable check	Refer to Chapter 3.

2) Daily check for DeviceNet module

Checking items		Description	Judgment basis	Action
Cable connection status		Cable loosening	No loosening	Tighten the cable
Module connection status		Screw loosening	No loosening	Tighten the module screw.
Indication LED	PWR LED	Light 'ON' check	Steady-state of Power	Refer to Chapter 3.
	MS LED	Light 'ON' check	Steady-state of communication module interface (if abnormal, check the H/W or the cable)	Refer to Chapter 3.
	NS LED	Light 'ON' check	Steady-state of communication module network (if abnormal, check Smart I/O H/W)	Refer to Chapter 3.

3) Daily check for Rnet module

Checking items		Description	Judgment basis	Action
Cable connection status		Cable loosening	No loosening	Tighten the cable
Module connection status		Screw loosening	No loosening	Tighten the module screw.
Indication LED	PWR LED	Light 'ON' check	Steady-state of power	Refer to Chapter 3.
	TX LED	Light 'ON' check	While sending/receiving with the master (if error occurs, check the H/W or the cable)	Refer to Chapter 3.
	RX LED	Light 'ON' check	While communicating with Smart I/O, (if error occurs, check Smart I/O Hardware.)	Refer to Chapter 3.

4) Daily check for Modbus module

Checking items		Description	Judgment basis	Action
Cable connection status		Cable loosening	No loosening	Tighten the cable
Module connection status		Screw loosening	No loosening	Tighten the module screw.
Indication LED	PWR LED	Light 'ON' check	Steady-state of power	Refer to Chapter 3.
	TX LED	Light 'ON' check	Steady-state of communication module interface (if error occurs, check the H/W or the cable)	Refer to Chapter 3.
	RX LED	Light 'ON' check	Steady-state of communication network (if error occurs, check Smart I/O hardware.)	Refer to Chapter 3.

13.3 Regular Check

Check the following items 1~2 times every 6 months and take the necessary actions.

Checking items		Checking method	Judgment basis	Action
Ambient environment	Temperature	Measure by thermometer/hygrometer.	0 ~ 55℃	Adjust suitable for general standard (in case of using in the area, apply the environment basis in the area)
	Humidity		5 ~ 95%RH	
	Pollution	Measure the corrosive gas.	No corrosive gas	
Module status	Loosening, shaking	Shake the communication module.	Tightening status	Tighten the screw.
	Dust, foreign material adding	Macrography	No adding	
Connection status	Terminal screw loosened	Tightening by the driver	No loosening	Tightening
	Pressed terminal approach	Macrography	Proper interval	Correction
	Connector loosened.	Macrography	No loosening	Connector correction Screw tightening
Power voltage check		Voltage measure between terminals	DC 20.4 ~ 28.8V	Power supply change

Chapter 14 Trouble Shooting

Here it describes the contents of each error to be occurred while operating the system, the method to find the cause and the action.

14.1 Basic Procedure of Trouble Shooting

It is important to use high reliable machine to increase the system reliability but it is important to take prompt action when trouble occurs as well.

To start the system promptly, it is more important to find the trouble occurring cause promptly and take the necessary action. The basic items to comply when taking this trouble shooting are as follows.

1) Check with the naked eye

Check the following items with the naked eye.

- Machine action status (stop, action)
- Power appliance status
- I/O machine status
- Wiring status (I/O cable, extended or communication cable)
- Check the indication status of each indicator (POWER LED, RUN LED, ERR LED, TX LED, RX LED, MS LED, NS LED, I/O LED etc.) and connect the peripheral device and then check the PLC action status or the program contents.

2) Check the trouble

Examine how the trouble is changed by the following action.

- Place the key switch on STOP position and apply power ON/OFF.

3) Limit range

Estimate the cause of trouble using the above method.

- Is it the cause from PLC itself? Or external cause?
- Is it the cause from I/O part? Or other cause?
- Is it the cause from PLC program?

14.2 Trouble Shooting

Here it describes the trouble finding method, the error code and the actions on the above by dividing them per phenomenon.

Description of Trouble

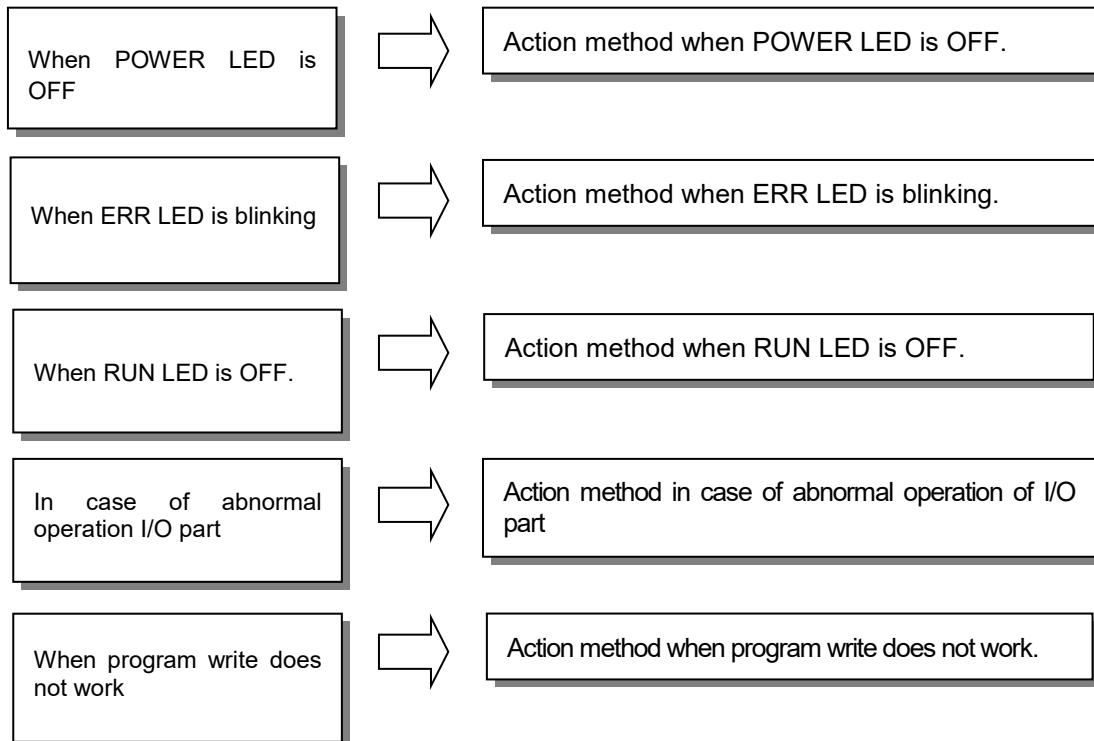

14.2.1 Action method when POWER LED is OFF.

Here it describes the action order when POWER LED is OFF while applying the power or during the operation.

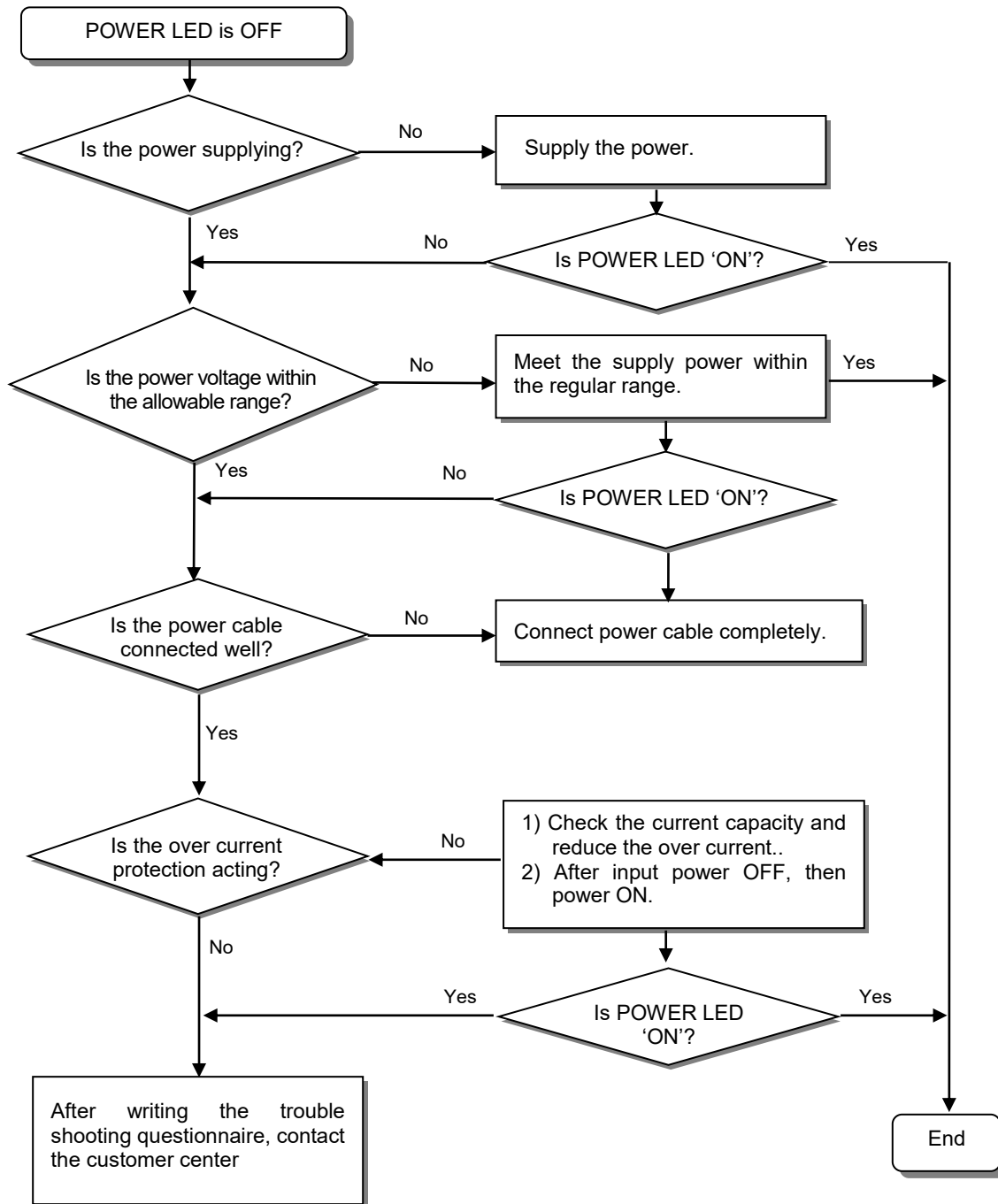

14.2.2 Action method when ERR LED is blinking.

Here it describes the action order when ERR LED is blinking in case of power input, or when operation start, or during operation.

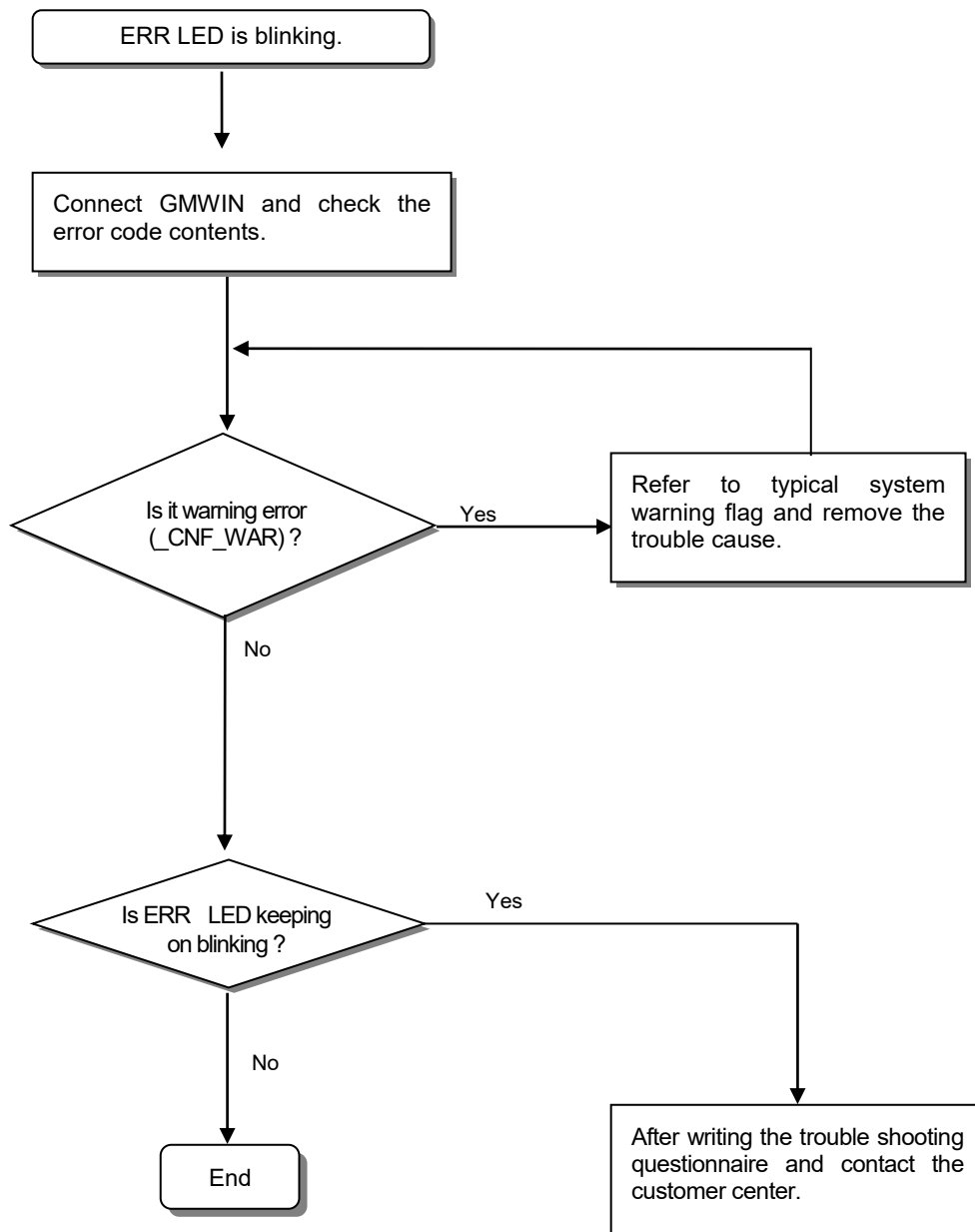

14.2.3 Action method when RUN LED is OFF

Here it describes the action order when RUN LED is blinking in case of the power input, or when operation start, or during operation.

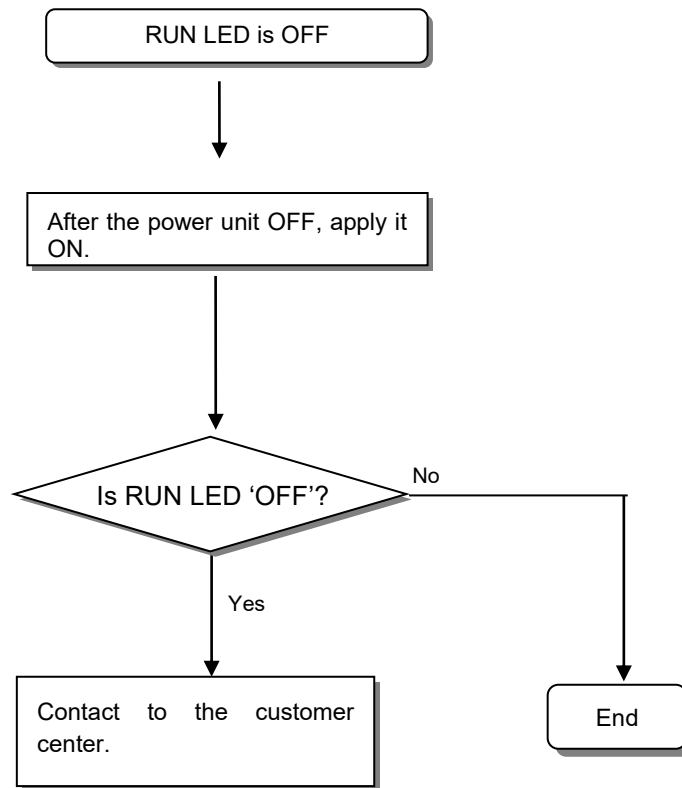

14.2.4 Action method when I/O part does not work normally.

Here it describes the action order when I/O part does not work normally during operation, as shown on the program example below.

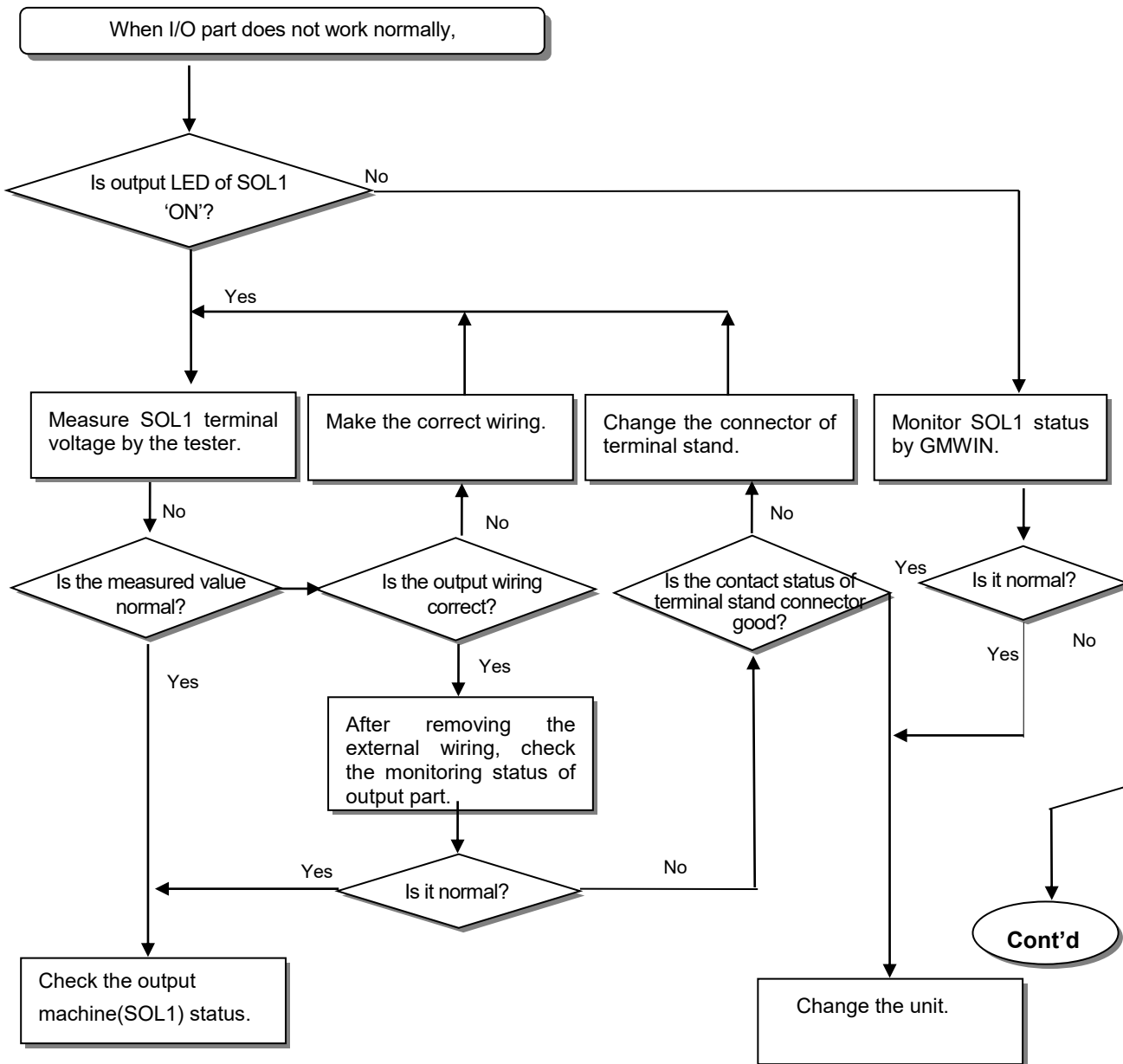
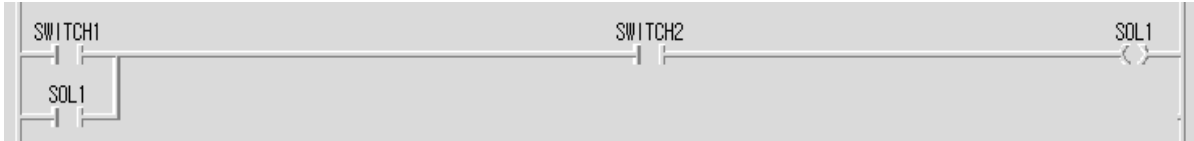

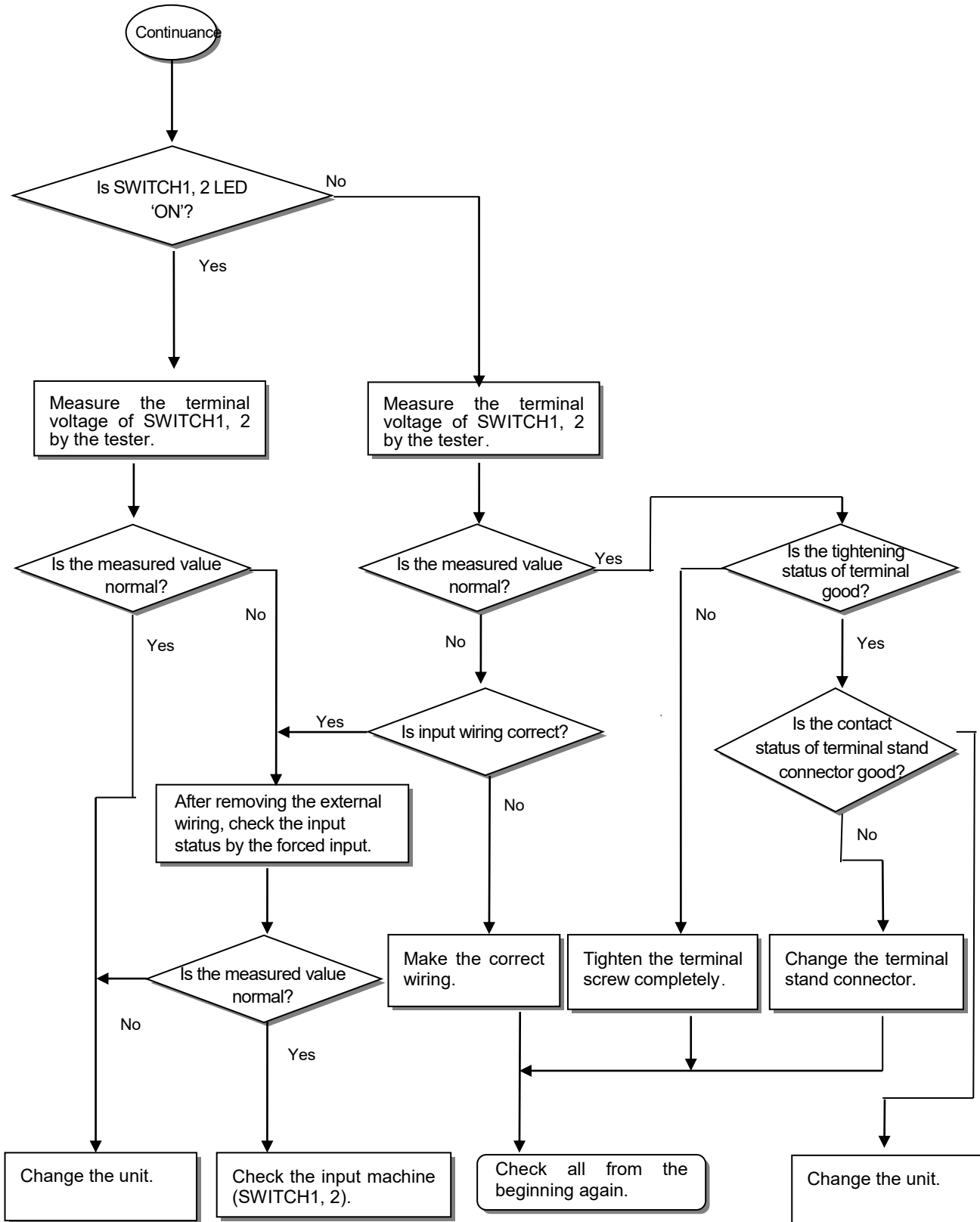

14.2.5 Action method when *Program Write* does not work

Here it describes the action order when Program write does not work in the Master CPU.

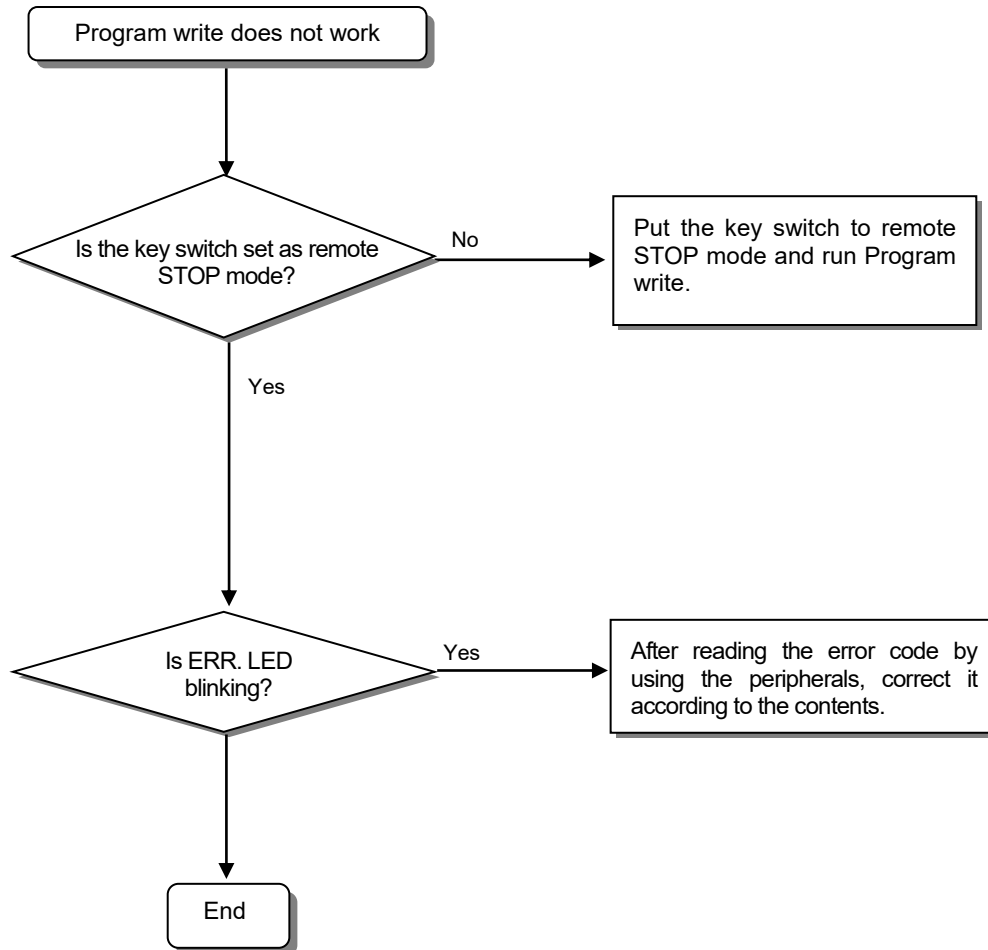

14.2.6 SyCon connection error

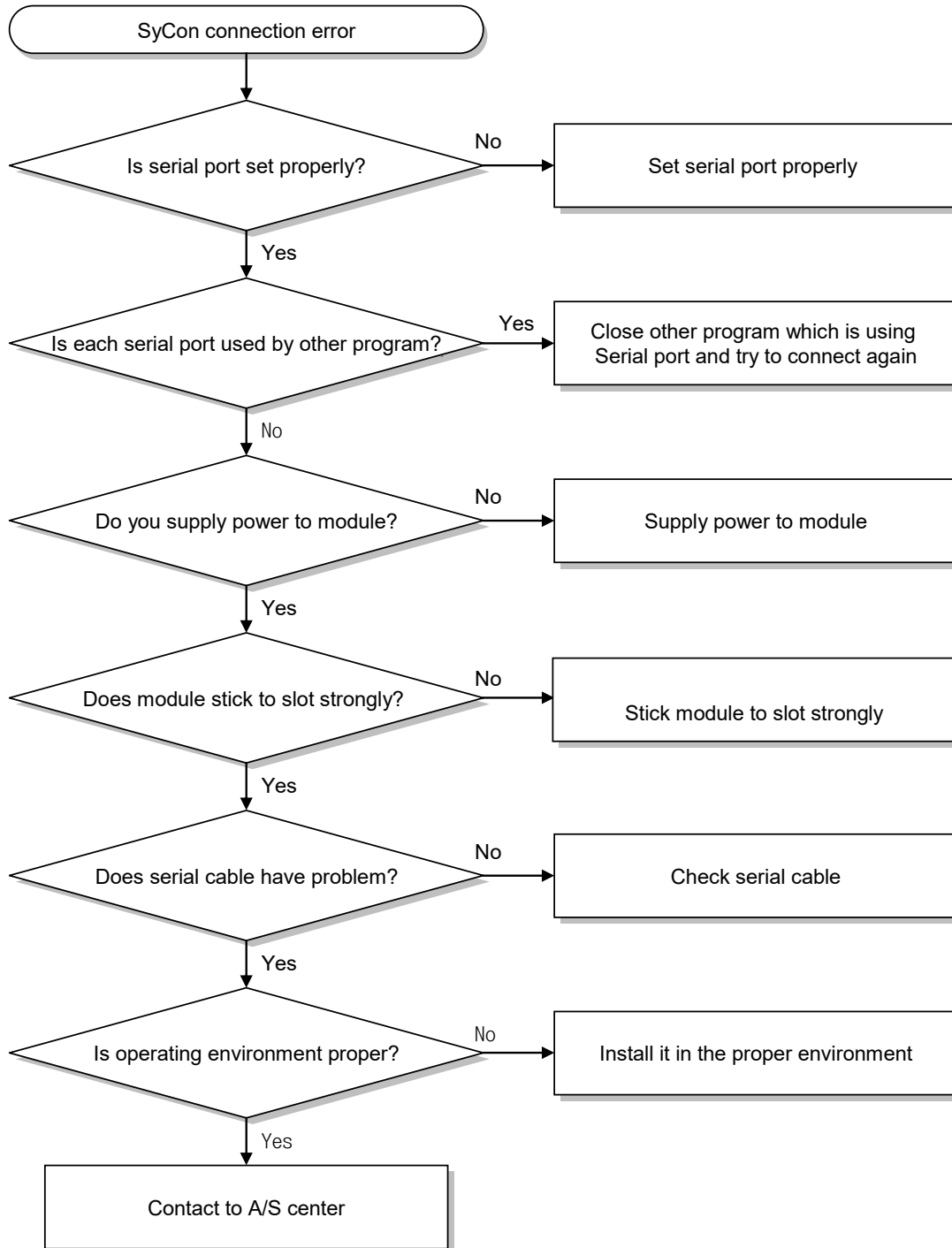

14.2.7 XG5000 connection error

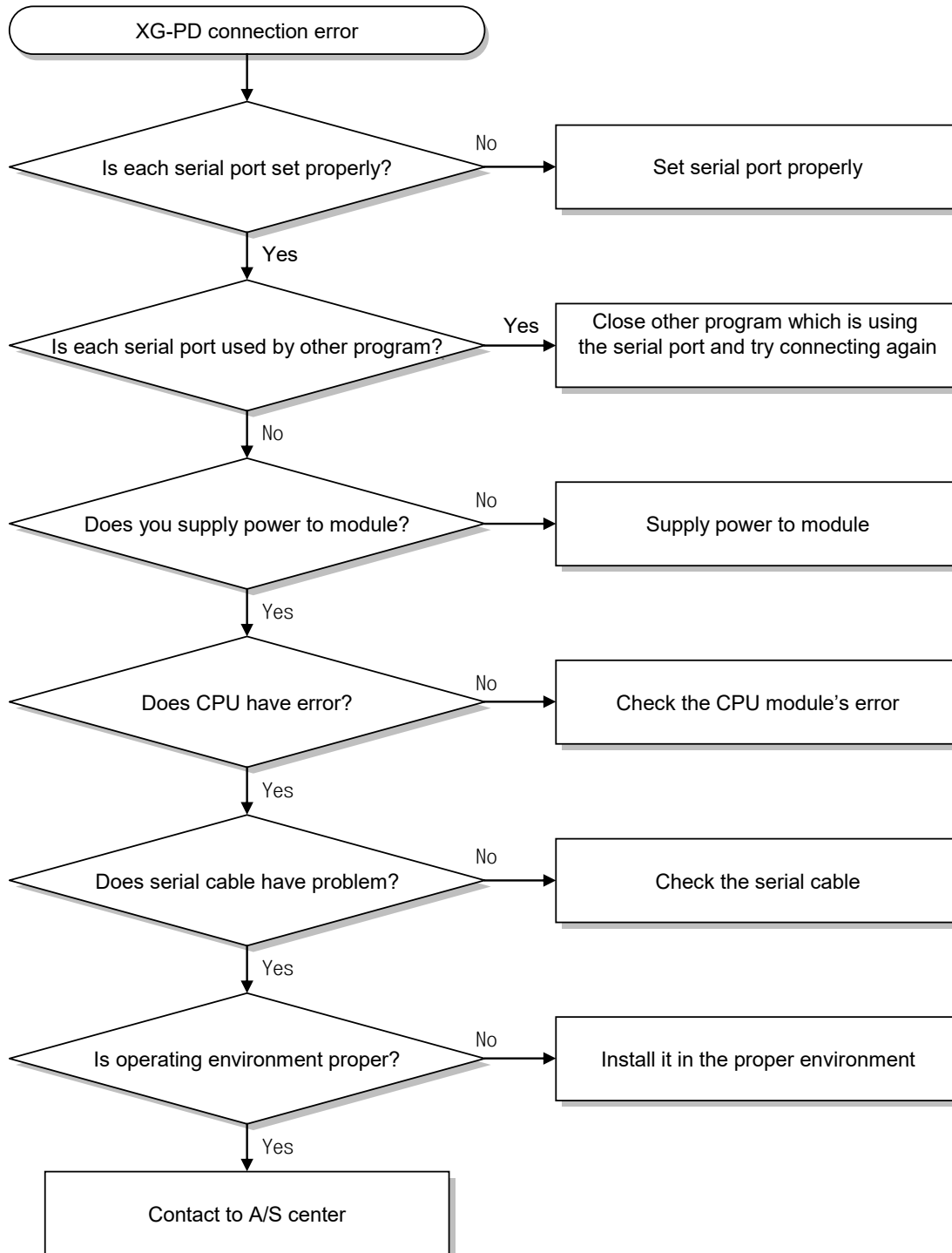

14.2.8 Communication error with slave

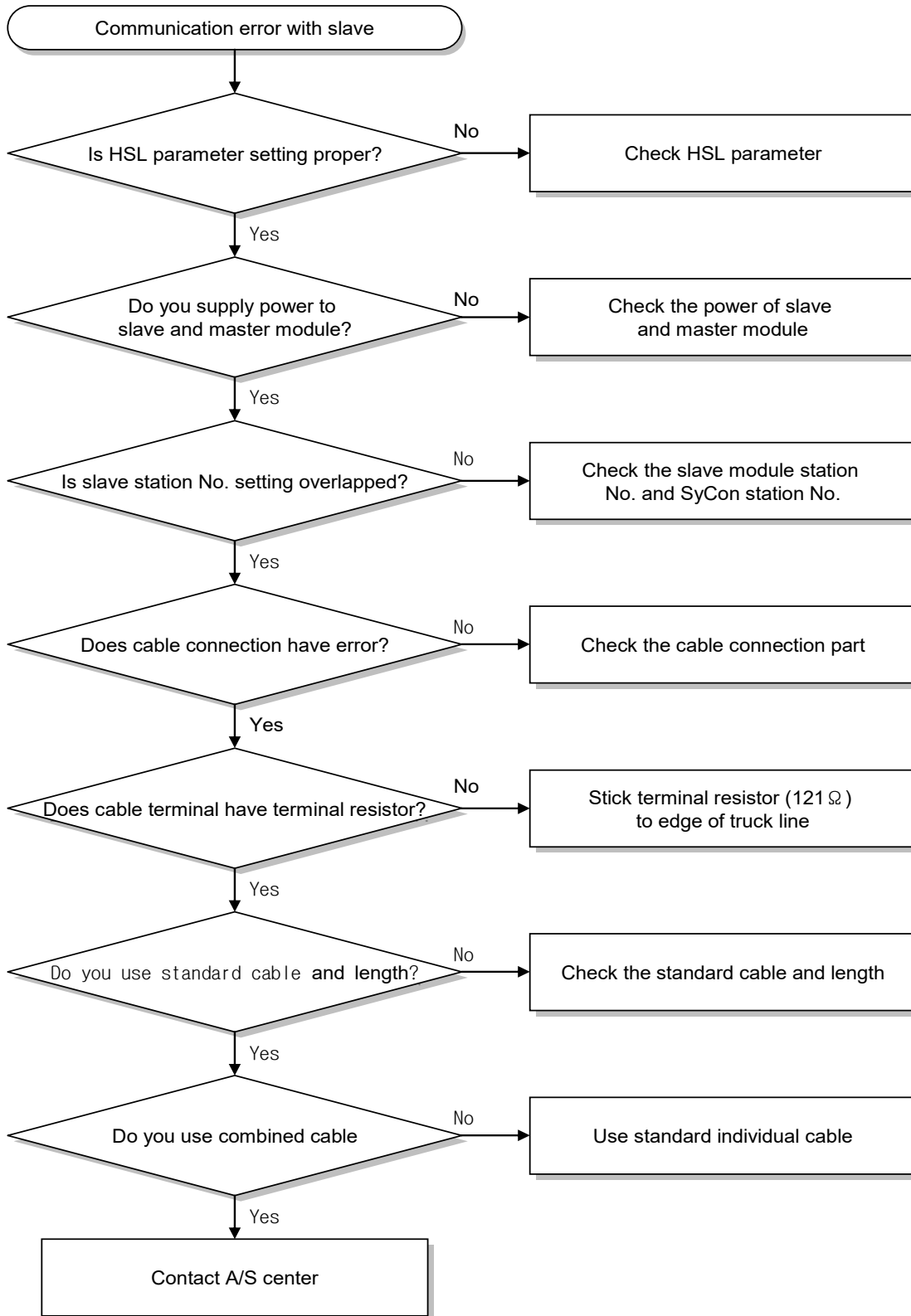

14.3 Trouble Shooting Questionnaire

If the trouble occurs when using SMART I/O series, fill in the following questionnaire and contact to the customer center by phone or by fax.

- In case of error related to specific and communication module, use the questionnaire added to the user's manual of the corresponding product.

1. User contact point : TEL.) _____
FAX) _____

2. Model : ()

3. Applied machine details

- Network status : – OS version (), – Serial no. of product ()
- GMWIN version no. used in program compile : ()

4. brief description of control object machine and system :

5. Network model using :

6. ERR LED 'OFF' of network unit? Yes(), No()

7. Error message content by GMWIN :

8. Action trial status for the error code. :

9. Trouble shooting method for other error action :

10. Error features

- Repeat(): periodical(), specific sequence level related()
environment related()
- Intermittent(): error interval :

12. Detail description for the error phenomena :

14. Configuration diagram of applied system:

APPENDIX

A.1 Communication Terminology

A.1.1 Profibus-DP

Profibus

Profibus is the protocol that Bosch, Siemens, Klockener-Moeller in Germany has developed and designated as German standard DIN 19245 as well as the network designated as European standard EN50 170 with WorldFIP, P-NET recently.

Profibus is used for the real time communication between field equipment in the field of production automation, processing control, building automation and the product group is divided into Profibus-FMS (Rnet Message Specification), Profibus-DP (Decentralized Periphery), Profibus-PA(Process Automation).

Profibus-FMS

This is the solution for general purpose that provides the communication function in the cell level including the function to send the program file to act the field equipment and the related data file, the function to control the program remotely through the network, and the function to manage the various accidents to be occurred in the process of control and automation system etc.

Profibus-DP

This is the communication method to send the real time data between field equipment within the shortest time and substitute the communication system using the existing 24V or 4~20 mA analog signal with high speed digital communication method. The example to be applied is the communication between field equipment such as various sensor and actuator etc. installed in the PLC and the field.

Profibus-PA

This is made specially for process automation and the safety device is embedded and available to connect the sensor and actuator with one common bus line and perform the data communication and the power supply on the bus using 2-wire technology in accordance with International Standard IEC 1158-2.

Sycon

This is a Profibus Network Configuration Tool and when using the LSIS Master module (G3/4/6L-PUEA) as a Profibus Network, use Sycon to configure Profibus Network and download the information to the corresponding master module.

GSD file

This is the electronic device data sheet and includes manufacturer name, device name, H/W and S/W release status, support transmission rate, master related spec. (max. slave number available to connect, upload/download option etc.) and slave related spec. (I/O channel number and type, diagnosis text spec. and module information equipped with modular device.).

EDD (Electronic Device Description)

This introduces the device registration information of field device generally. It allows to describe the complicated automation system as well as simple field device (such as sensor and actuator) regardless of manufacturer. The device description is provided per device in the electronic form made by the manufacturer and EDD file is read by engineering tool and enables Profibus system to be set easily. And it describes the device variable and its function as well as contains the elements for operation and visualization.

Broadcast Communication

This means to send the message not recognized by the action Station to all Station (Master, Slave).

Multicast Communication

This means that the action station sends the not recognized message to the pre-defined Station group (Master, Slave).

A.1.2 DeviceNet

ODVA (Open DeviceNet Vendor Association)

This is to contribute for the promotion of World industrial Automation technology, DeviceNet and the related technology. It participates in the exhibition for technical seminar and PR activity and writes/distributes the technical documents to attract the attention of the sales agents and the user for DeviceNet. ODVA's activity includes the PR of DeviceNet Specification for each industrial sales organization in charge of network standardization, the requirements of the expansion or amendment for DeviceNet Specification according to the requirement of the market when the same Specification is selected in the real industrial automatic control system, and the proposal of the expansion or amendment of DeviceNet Specifications to the ODVA.

Bus-off

When the trouble occurs in the power of network, the error will occur.

CAN (Controller Area Network)

This is the communication protocol designed for automobile exclusive communication. Device network adapted CAN technology.

Scanlist

If the master module wants to communicate with the Slave module, it is required to know all information of the slave module (station address, message selection (Poll, Strobe etc.)) and set. This information is called 'Scanlist'. Dnet I/F module of GLOFA-GM PLC can set this easily just by high speed link parameter setting in GMWIN.

Connection

This means the logical connection between master and slave connected by DeviceNet and is used to maintain and manage all communication.

Profile

This provides the information for Device Configuration data. (Printed data sheet, EDS; Electronic Data Sheet etc.)

Master/Slave

The module to send/receive and manage the data is 'master module' and the module to reply to the data that the master module sends is 'slave module'.

Packet

This is a pack of data that is a basic unit to transmit the data through the network. It attaches the header (Message Identifier) to the front part to add the information of the destination to go and other necessary information etc.

A.1.3 Rnet

Master module (Rnet Master Module: RMM)

This is Rnet I/F module that is installed I/O digit of basic base.

Master station

This is the station connected directly GMWIN/KGLWIN so that the user performs the program download and monitoring/debugging in the same network including CPU.

Remote I/O station

Remote I/O module controls the I/O of remote station receiving I/O data from master station instead of PLC CPU in the PLC system.

Rnet

Fieldbus is the lowest network connecting the control machine and instrument device, selecting 3 among 7 layers of OSI. 3 layers are composed of Physical layer which is composed of H2 (1Mbps electric), H1 (31.23Kbbs electric), light, Wireless etc., Data Link layer selecting the Scheduled and Circulated Token bus, and Application layer that charges in the application role and this is the standard selecting the 'User layer' additionally.

Token

This is the access right control for Physical Medium and has the right to send the data of self station.

Rnet station no.

Station no. (G3L-RUEA...etc.) of communication module selecting Rnet specification. The station no. used in Rnet shall be set by the switch attached in the front of communication module and used as station no. of all service including high speed link service.

Manchester Biphase-L

This is data modulation method used in Rnet. The data is encoded (Encode) using Manchester-L Code and sent and the received data after encoding by Manchester is converted by Decoding.

CRC (Cyclic Redundancy Check)

This is one of error detection method and is used widely for the synchronous transmission that is called as 'cyclic sign method'.

Terminal resistor

This is the resistance to be used to meet the mutual impedance between sending/receiving side of Physical Layer and Terminal resistance of Rnet 110Ω, 1/2W.

High Speed Link

This is the communication method to be used only between Rnet communication module so that the user can send/receive the data with high speed. The communication is carried out by setting the high speed link parameter in GMWIN/KGL-WIN.

Segment

This is the local network connecting all station by using the same Token without using any other connecting device (Gateway, repeater).

Network

This is the overall communication system composed of more than one segment and using the same Token.

A.1.4 Modbus

Protocol

This is the communication regulation pre-defined on the sending/receiving side of information to send/receive the efficient and reliable information without error between more than 2 computer and terminals. Generally, it defines the establishment of calling, connection, structure of message exchange form, retransmission of error message, line inversion procedure, character synchronization between terminal etc.

BPS (Bits Per Second) and CPS(Characters Per Second)

BPS is the transmission rate unit how many bit is transmitted per second when transmitting the data and CPS is the number of character to be transmitted per second. Usually 1 character is 1Byte(8Bit) and thus, CPS is the byte number available to transmit per second.

Node

This means the connecting joint of data in network tree structure and generally the network is composed of lots of node. This is expressed also as Station no.

Packet

This is the term used in packet exchange method that divides the information into packet unit and transmits and also is the compound term of Package and Buket. Packet is the thing attached the header indicating the address of other station by dividing the transmitting data into the designated length.

Port

This is a part of data processing device to send/receive the data from remote terminal in the data communication and in case of Cnet serial communication.

RS-232C

This is the serial communication standard designated by EIA according to the recommendation of CCITT as the interface to connect the modem and terminal or model and computer. This is used for modem connection as well as direct connection to the null modem. The demerits are that the transmission distance is short and only 1:1 communication is available. The specification that overcome this demerits is RS-422, RS-485.

RS-422/RS-485

This is one of serial transmission specification and the transmission distance is long and 1:N connection is available comparing with RS-232C. The difference between 2 specification is that RS-422 uses 4 signal cable such as TX(+), TX(-), RX(+), RX(-) while RS-485 has (+), (-) 2 signal cable and performs the sending/receiving through the same signal cable. So, RS-422 performs full duplex mode communication and RS-485 performs semi duplex mode communication.

A.1.5 Ethernet

IEEE 802.3

IEEE 802.3 specifies standards regarding to CSMA/CD-based Ethernet. More specific, it is a Local Area Network (LAN) based on CSMA/CD (Carrier Sense Multiple Access with Collision Detection) Ethernet designed by IEEE 802.3 Group and it is divided into three sub projects as below:

- (1) IEEE P802.3 - 10G Base T Study Group
- (2) IEEE P802.3ah - Ethernet in the First Mile Task Force
- (3) IEEE P802.3ak - 10G Base-CX4 Task Force

※ Ethernet and IEEE 802.3 are standardized by RFC894 and RFC1042, and they shall conduct frame treatment mutually.

ARP (Address Resolution Protocol)

A protocol to find MAC addresses by using partner's IP address on the Ethernet LAN.

Bridge

A device used to connect two networks together to ensure they act as if they are one network. Even though Bridge is used to connect two different types of networks, it is also used to divide one large network into two small networks to improve its performance.

- (1) Related standard : IEEE 802.1D
- (2) Bridge (Layer 2 Switch) is a device to link to Layer2 and it extends the limit of distribution of Ethernet, performing filtering and forwarding.

Client

A network service user or, a computer or a program using other computer's resource (Mainly the party who requests the service.)

CSMA/CD (Carrier Sense Multiple Access with Collision Detection)

Before sending data to the network, each terminal (Client) checks if there is any signal on the network (Carrier Sense) and sends data when the network is empty. At this time, all terminals have the equal authority to send data (Multiple Access) and, if more than two terminals send data and any collision takes place, the terminal that detects this resends data after a few minutes later (Collision Detect).

DNS (Domain Name System)

A method used to convert a domain name in Alphabet on the Internet to its corresponding Internet number (IP Address)

Dot Address

It is expressed in '100.100.100.100', representing IP Address. Each number is expressed in decimal and dominates each one byte of total four bytes.

E-mail Address

The address of the user who has a login account on a specific device connected to the Internet. Typically, it forms like the user's ID@ domain name (device name). It looks like this example, hjjee@microsoft.com, where, @ is called 'at' and it appears on the screen if shift key and number 2 are pressed simultaneously on the keyboard. The letters after @ represent the domain name of a specific organization (school, research center, company...) connected to the Internet and the letters before @ show the user's ID. The last few letters are for the top level. For example, if it is the US, most cases show the following abbreviation words, and if it is Korea, 'kr' is used. .com : companies / .edu : mainly universities or other educational organization (education). / In Korea, .ac(academy) is widely used., / .gov : government agencies, For example, nasa.gov is used for NASA(government) / .mil : military related sites. For example, af.mil is used for the US Air Force (military)/ .org : private entities. Each nation is identified as follows:/ .au : Australia / .uk : the United Kingdom / .ca : Canada / .kr : Korea / .jp : Japan / .fr : France / .tw : Taiwan etc.

Ethernet

A representative LAN link system (IEEE 802.3) jointly developed by the US Xerox, Intel and DEC. As a network link system with 10Mbps transmission capability using 1500-byte packets, Ethernet is called a major term of LAN because it can bind various kinds of computer with a network. Various goods are available because it is not a standard only for a certain company but a universal standard,

FTP (File Transfer Protocol)

As one of the application programs provided by TCP/IP protocol, it can be used to transfer files between computers. Only if only the user has an account on the computer he wants to log in, it is possible to log in to the computer fast and copy data on it to bring in wherever the computer is in the world.

Gateway

Software/hardware to translate two different protocols into those that can work well each other. A device that serves as a gate where information exchange takes place among different systems

Header

Part of a packet containing national address or partner nation's address and part for error inspection

HTML (Hypertext Markup Language, Standard Language of WWW)

A language system to create a hypertext document, Any document made in HTML can be viewed through web browser.

HTTP (Hypertext Transfer Protocol, Standard Protocol of WWW)

A protocol used for the purpose of sending and receiving various files and data on the World Wide Web (WWW)

ICMP (Internet Control Message Protocol)

An extension protocol of IP Address for the purpose of creating error messages and test packets and reporting and controlling errors to ensure the Internet is properly managed.

IP (Internet Protocol)

This is a protocol of the network layer for the Internet. It is non-connection datagram type protocol, and data such as TCP, UDP, ICMP, IGMP is transmitted and received by using IP(32 bits).

IP Address

This refers to the address of each computer in the internet. It is binary number with 32 bits (4 bytes) to identify each device in the internet. IP address is composed of two parts. One is network address to identify network and the other is host address to identify host. It is divided into class A/ B/ C according to how many bits are allocated to network address and host address respectively. Since each IP address is unique in the world, it is not decided discretionally. When subscribing internet, the Network Information Center (NIC) allocates the address. For Korea, KRNIC is in charge of this role. e.g.) 165.244.149.190

ISO (International Organization for Standardization)

This organization is a subsidiary organization of UN, and it establishes and manages international standard specification.

LAN (Local Area Network)

This is also called as information network in the local area. This refers to the network where multiple computers are connected by communication lines to exchange data in a limited range like one office or building.

MAC (Medium Access Control)

A method to decide which device will be used for a given time on the Broadcast network.

Node

Each computer connected to the network is called a nod.

Packet

This is a packet of data, the basic unit for transmitting data via the network. Usually the size of one packet is between tens and hundreds bytes, and header is attached to the front of the packet to include information about the destination that where this packet should go and other necessary information.

PORT number

This is an identifier to identify application on TCP/UDP. TCP determines that data is sent to which application after identify this port number. The programs used in general operating system have each port.

Ex.) 21/tcp : Telnet

PPP (Point-to-Point Protocol)

This is telephone communication protocol to allow packet transmission in connecting internet. This is the most common internet protocol when computer is connected to TCP/IP by using normal telephone line and modem.

This is similar to SLIP, but it shows more excellent performance than SLIP since PPP has modern communication protocol elements such as error detection and data compression, etc.

Protocol

This refers to the rules about how computers connected to network can send and receive information mutually. Protocol also means low level description (e.g. which bit/byte should be out through the line) for interface between devices, or high level message exchange rules like transmitting files through internet.

Router

A device used to transmit data packet between networks. It sends data packets to the destination and holds them if the network is crowded and also judges which LAN is better to connect to at a junction of multiple LANs. That is, it refers to special computer software that manages connection of more than two networks.

Server

A party to passively respond to the client's request and share its own resource.

TCP (Transmission Control Protocol)

(1) Transport Layer Protocol for the Internet

- Support sending/receiving data by using connection.
- Support multiplexing function
- Perform a reliable connection-oriented transmission of data
- Support emergency data transmission

TCP/IP (Transmission Control Protocol/Internet Protocol)

This refers to the transmission protocol for communications between different type of computers. It plays a role to enable communications between general computers and mid-sized host, IBM PC and MAC, and different companies' mid-sized computers. This is used as general name of protocol for transmitting information between computer networks, and it includes FTP, Telnet and SMTP. TCP divides data into packet and it is transmitted by IP. The transmitted packet is reorganized by TCP.

Near-end crosstalk

Crosstalk is a sort of disturbance incurred from electricity or magnetic field of communication signal, which affects another signal of near line. In telephone line, crosstalk may cause to hear some of the talks of another line. The phenomenon caused by crosstalk is also called as electromagnetic interference (EMI). This also happens in small circuit inside of computer or audio equipment as well as network line. This term may be applied to optical signals which interfere with each other. For example, like insulated conductor of telephone cable, there may be electrostatic coupling or electromagnetic coupling between any insulated conductor and another insulated conductor. And call current of one insulated conductor may be exposed to another conductor, and cause the crosstalk phenomenon. When crosstalk occurs at the transmission side, it is called as near-end crosstalk, and when crosstalk occurs at the receiving side, it is called as far-end crosstalk.

A.2 External Dimension

1) External dimension of 16 point unit

The external dimension of Pnet, Rnet, Snet etc are all same.

Unit: mm

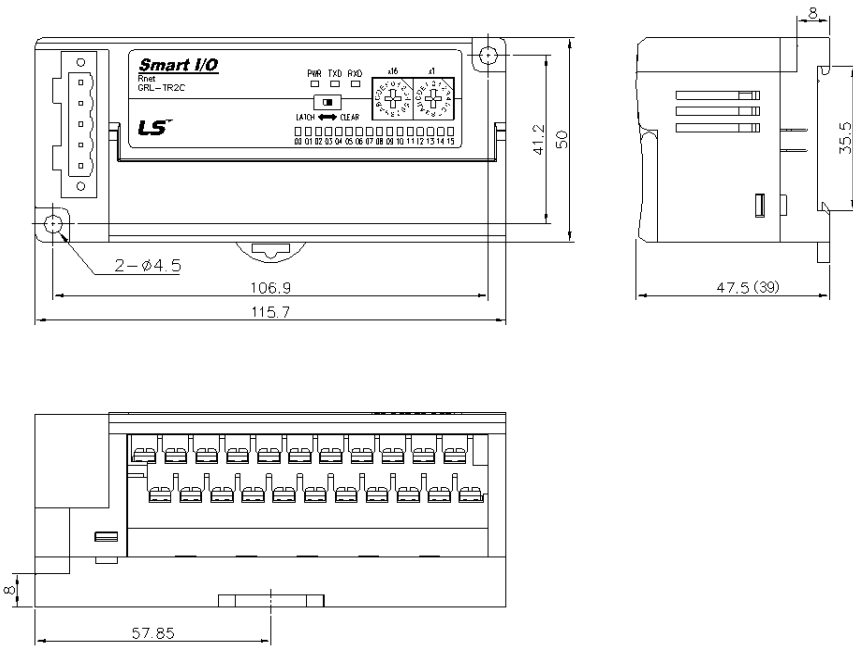

2) External dimension of 32 point unit

The external dimension of Pnet, Rnet, Snet etc are all same.

Unit: mm

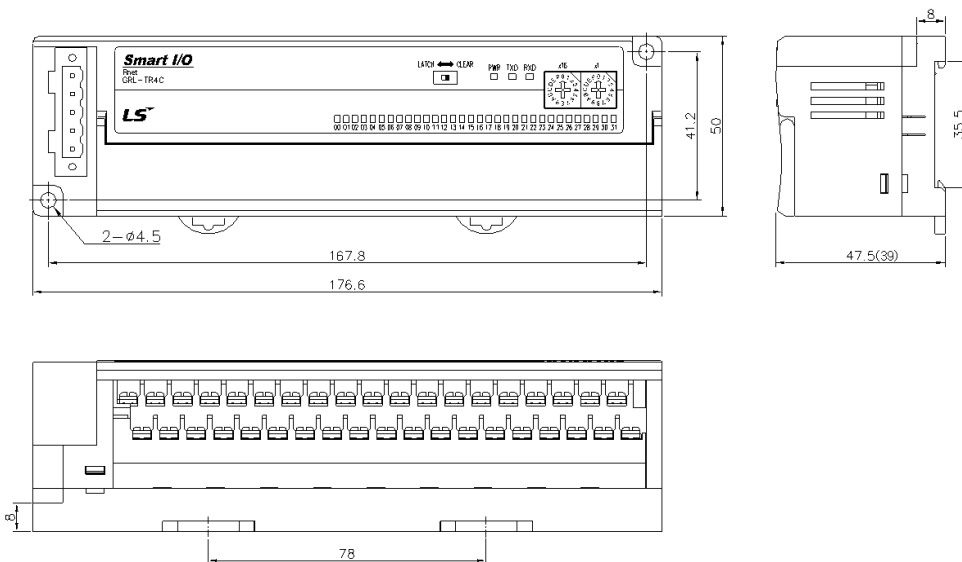

3) External dimension of 16 point unit

The external dimension of Dnet is as follows.

Unit: mm

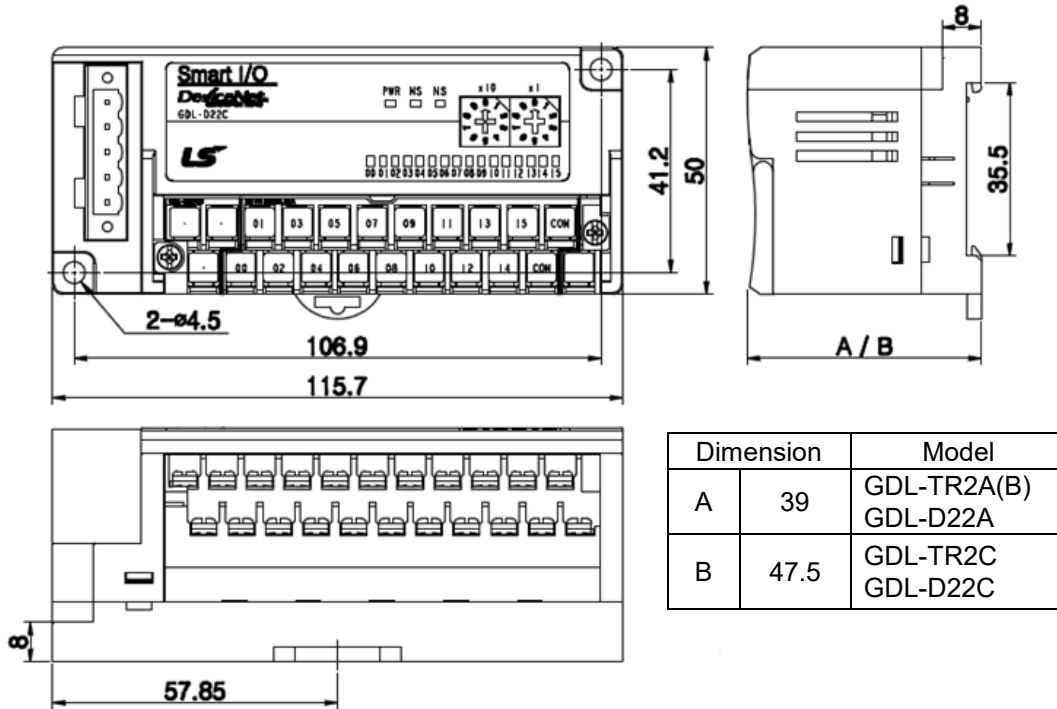

4) External dimension of 32 point unit

The external dimension of Dnet is as follows.

Unit: mm

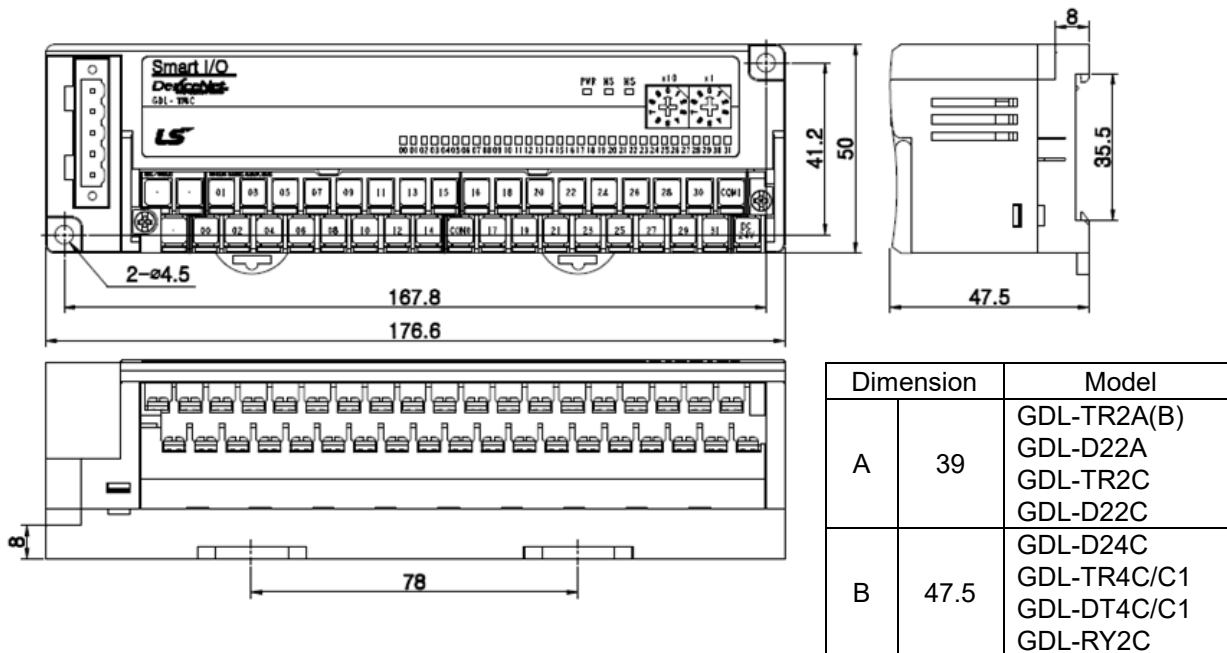

5) Expansion type I/F unit's External dimension

Expansion type Smart I/O Pnet,Dnet external dimension is as follows.

Unit: mm

(1) Pnet

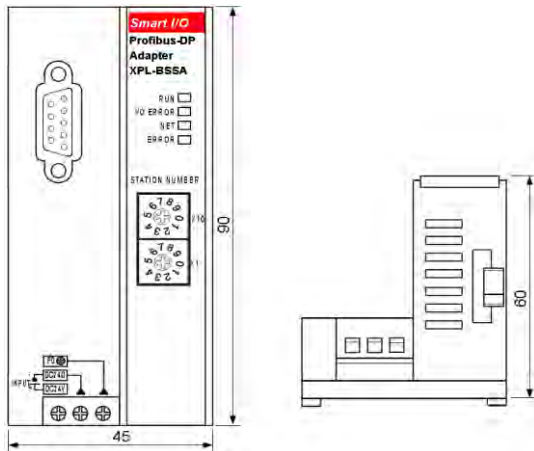

(2) Dnet

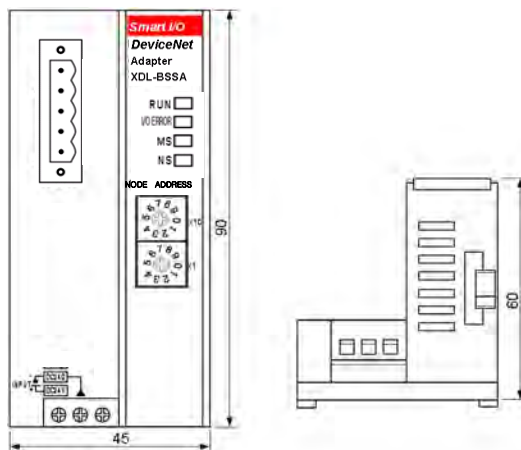

(3) Rnet

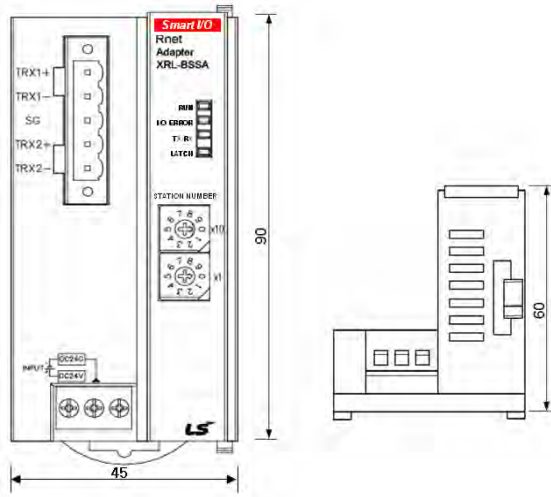

(4) Enet

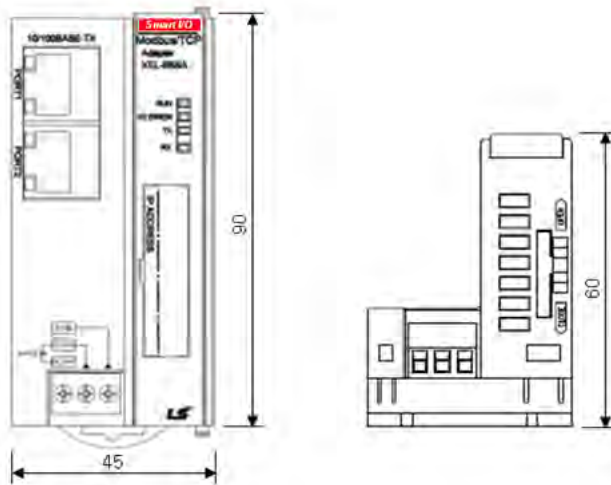

A.3 Expansion type analogue module parameter setting method (XDL-BSSA)

A.3.1 Analogue I/O module parameter setting standard

(1) XBF-AD04A

address	7	6	5	4	3	2	1	0	meaning
0					C H 3	C H 2	C H 1	C H 0	<channel Enable_low byte> Bit On(1): run Bit off(0): stop
1	CH3		CH2		CH1		CH0		<Input V/I range designation> Bit(00): 0~10V Bit(01): 0~20mA Bit(10): 4~20mA
2	CH3		CH2		CH1		CH0		<output data range designation> Bit(00): 0~4000 Bit(01): -2000~2000 Bit(10): standard value (0~1000/400~2000/0~2000) Bit(11): percent value(0~1000)

(2) XBF-DV04A

address	7	6	5	4	3	2	1	0	meaning
0					C H 3	C H 2	C H 1	C H 0	<channel Enable_low byte> Bit On(1): run Bit off(0): stop
1	CH3		CH2		CH1		CH0		<Voltage range setting> Bit(00): 0~10V
2	CH3		CH2		CH1		CH0		<input data type setting> Bit(00): 0~4000 Bit(01): -2000~2000 Bit(10): 0~1000 Bit(11): 0~1000

(3) XBF-DC04A

address	7	6	5	4	3	2	1	0	meaning
0					C H 3	C H 2	C H 1	C H 0	<channel Enable_low byte> Bit On(1): run Bit off(0): stop
1	CH3		CH2		CH1		CH0		<current range setting> Bit(00): 4~20mA Bit(01): 0~20mA
2	CH3		CH2		CH1		CH0		<input data type setting> Bit(00): 0~4000 Bit(01): -2000~2000 Bit(10): 400~2000/0~2000 Bit(11): 0~1000

(4) XBF-RD04A

address	7	6	5	4	3	2	1	0	meaning
0					C H 3	C H 2	C H 1	C H 0	<channel Enable_low byte> Bit On(1): run Bit off(0): stop <Tmp. indication unit designation_high byte> Bit On(1): Fahrenheit Bit off(0): Celsius
1	CH3		CH2		CH1		CH0		<Sensor input range setting> Bit On(1): JPT100 Bit Off(0): PT100

(5) XBF-TC04S

Address	7	6	5	4	3	2	1	0	Meaning
0	C H 3	C H 2	C H 1	C H 0	C H 3	C H 2	C H 1	C H 0	<CH Enable_low byte> Bit On(1): run Bit Off(0): stop <Tmp. indication unit designation_high byte> Bit On(1): Fahrenheit Bit off(0): Celsius
1	CH 3		CH 2		CH 1		CH 0		<Sensor input type setting> K type: 00, J type: 01 T type: 10, R type: 11

(6)XBF-AH04A

Address	7	6	5	4	3	2	1	0	Meaning
0	INPUT CH1				INPUT CH 0				<I/O range setting> Bit(0000): 4 ~ 20 mA Bit(0001): 0 ~ 20 mA Bit(0010): 1 ~ 5 V Bit(0011): 0 ~ 5 V Bit(0100): 0 ~ 10 V
1	OUTPUT CH 1				OUTPUT CH 0				
2	OUTPUT CH 1		OUTPUT CH 0		INPUT CH 1		INPUT CH 0		<I/O data type setting> Bit(00): 0 ~ 4000 Bit(01): -2000 ~ 2000 Bit(10): precise value Bit(11): 0 ~ 1000 - In case of precise value 4 ~ 20 mA: 400 ~ 2000 0 ~ 20 mA: 0 ~ 2000 1 ~ 5 V: 100 ~ 500 0 ~ 5 V: 0 ~ 500 0 ~ 10 V: 0 ~ 1000

Note**Caution in setting an analog parameter**

- (1) For analog module, all channels are set as Enable status internally.
- (2) If you don't set any parameter, module operates with initial parameter value.
- (3) The setting parameter is sent from master to slave.

A.3.2 Analog parameter setting method

Configure the Dnet adapter which is slave module in the SyCon. (But this time use EDS file as XDL-BSSA.EDS).
 Slave module setting method in the network can be divided into 'manual setting' and 'auto setting'

(1) Manual setting

Execution method: SyCon → Insert → Device...

The following screen shows

(2) Auto setting

Execution method:

SyCon → Online → Automatic Network Scan → Double-click the each module

The following screen shows.

<Setting screen 1>: click parameter setting button.

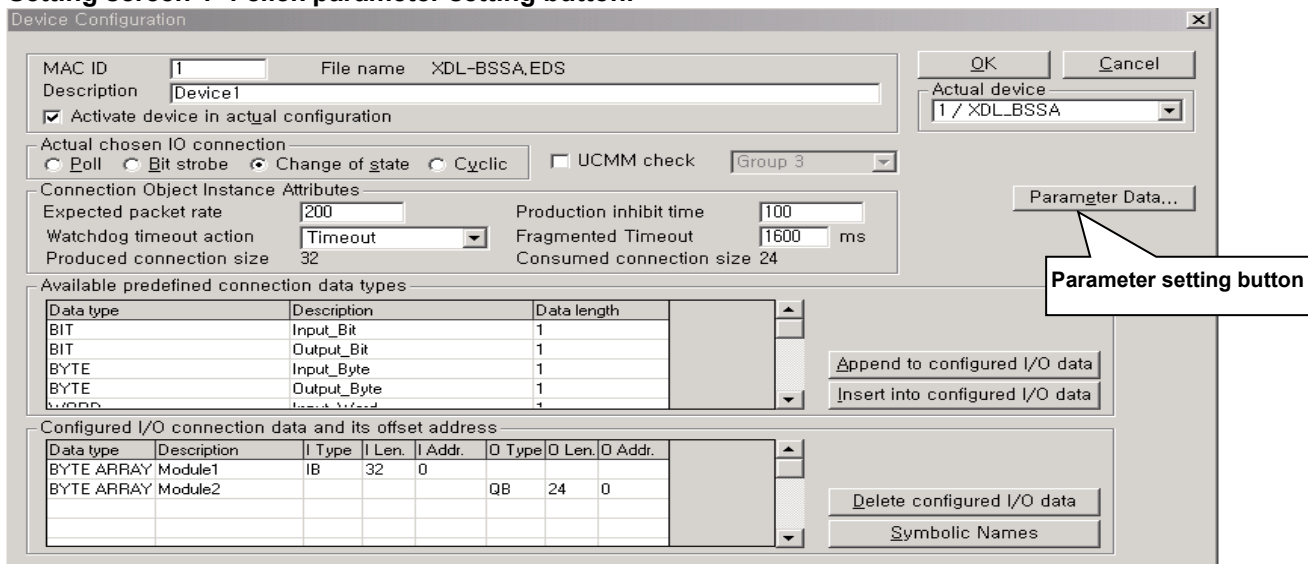

<Setting screen 2>: In the Available Parameters project window, double-click the slot you want to set parameter. After double-click, Customized Parameters window shows.

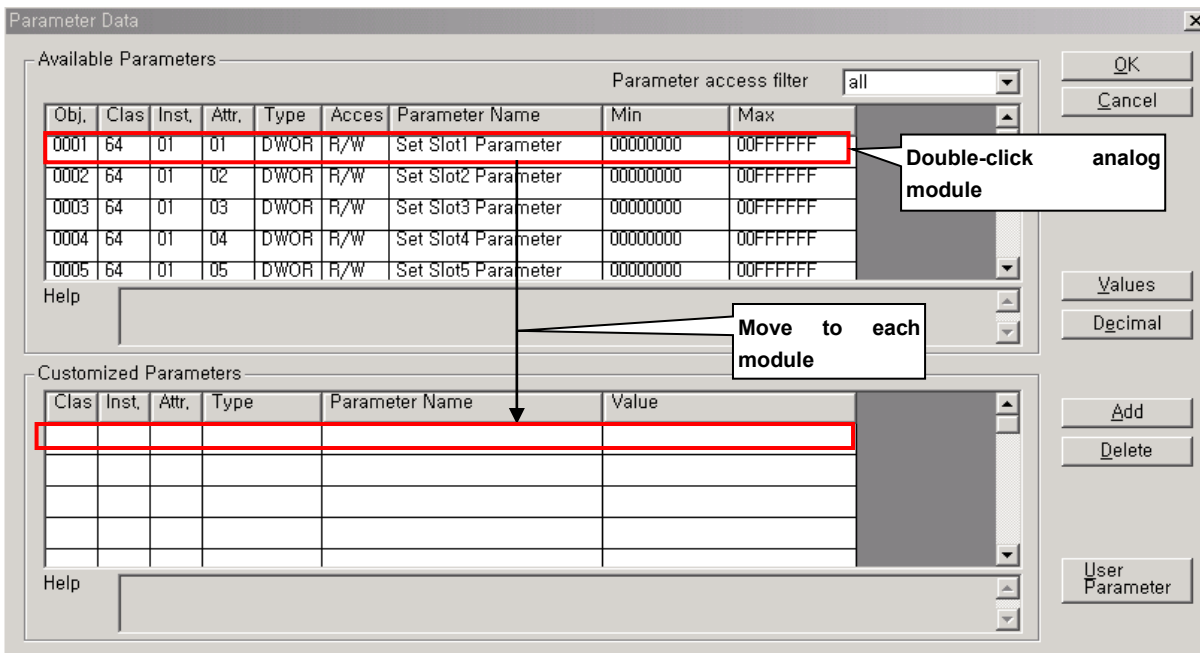

<Setting screen 3>: set parameter value at 'Value' in the Customized Parameters window.

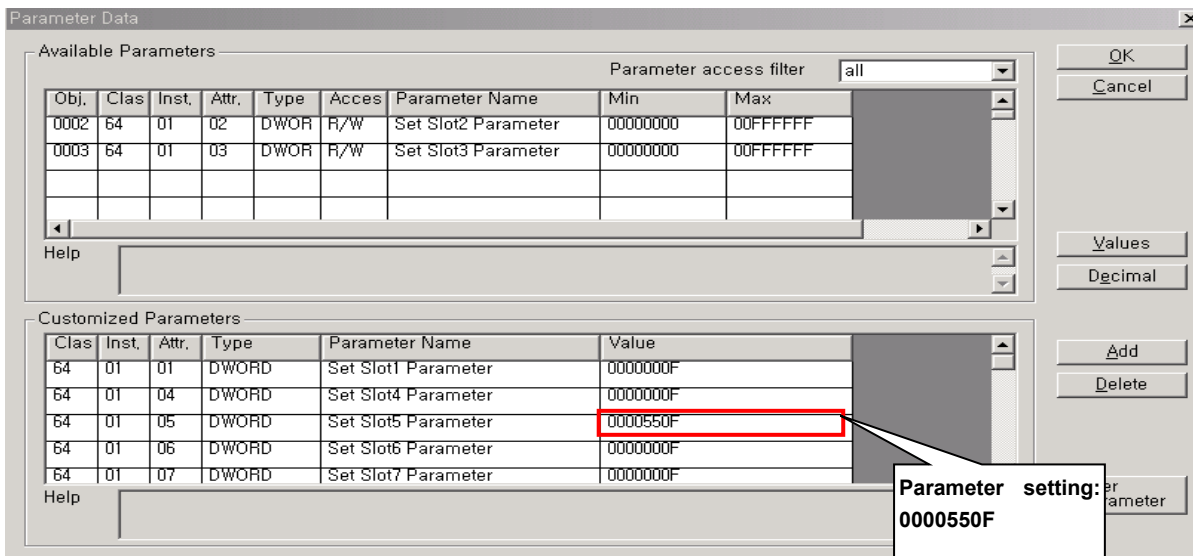

<Setting screen 4>: When completion of parameter setting, download it to master module **SyCon** → **Online** → **Download** :

<Setting screen 5>: Turn off/on expansion type Smart I/O Dnet's DC 24V power.

<Setting screen 6>

1) When setting network first

Setting HSL parameter through the XG-PD

2) When changing the analog parameter after network setting

SyCon → Online → Start Communication

<System configuration example: 1station>

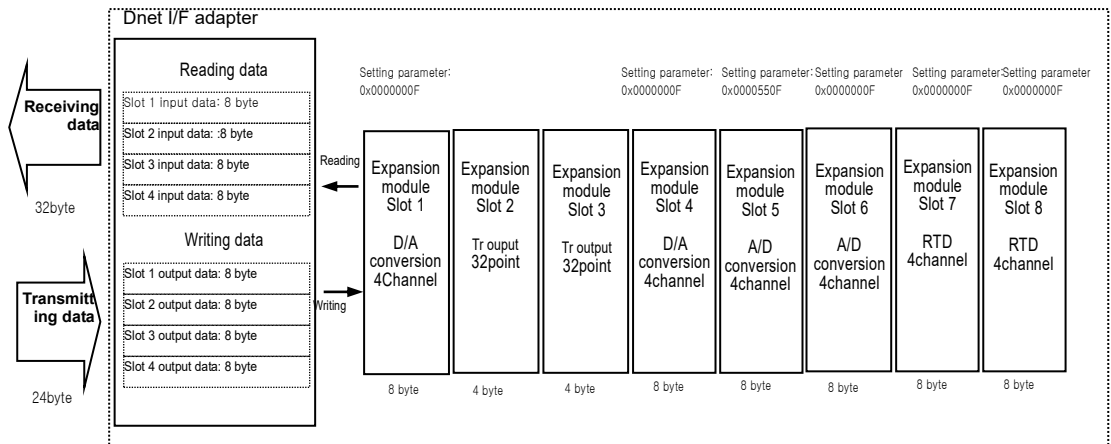

<Parameter setting contents example per each module>

Module	Mode	Setting parameter	contents
XGF-DV04A	-	0x0000000F	1. all channels: enable 2. voltage range: 0~10V 3. data type: 0~ 4000
XGF-AD04A	Current	0x0000550F	1. all channels: enable 2. current range: 0~20mA 3. data type: 0~4000
XGF-AD04A	Voltage	0x0000000F	1. all channels: enable 2. voltage range: 0~10V 3. data type: 0~4000
XGF-DC04A	-	0x0000000F	1. all channels: enable 2. current range : 4~20mA 3. data type: 0~4000
XGF-RD04A	-	0x0000000F	1. all channels: enable 2. Temp. unit: Celsius 3. sensor range: PT100
XGF-TC04S	-	0x000000FF	1.all channels: Enable 2.all channels temp. unit: Fahrenheit 3.all channels sensor type: K
XGF-AH04A	-	0x00004444	1.all channels: Enable 2.all input channels range: 0~10V 3.all output channels range: 0~10V 4.all channels data type: 0~4000

*When not setting the parameter, all analog modules are set as default value (0x0000000F)

- 1) XBF-AD04A : All channel (Enable), input (DC 0~10 V), data range (0 ~ 4000)
 → This value is effective when switch is off, voltage mode.

In case of current mode, you should modify the parameter value.

< Parameter setting value's meaning >

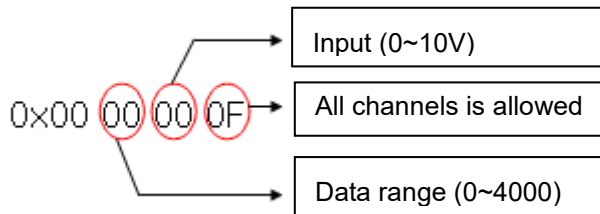

- 2) XBF-DV04A: all channels (Enable), output (DC 0~10 V), data range (0 ~ 4000)
 XBF-DC04A: all channels (Enable), output (4 ~ 20 mA), data range (0 ~ 4000)

< Parameter setting value's meaning >

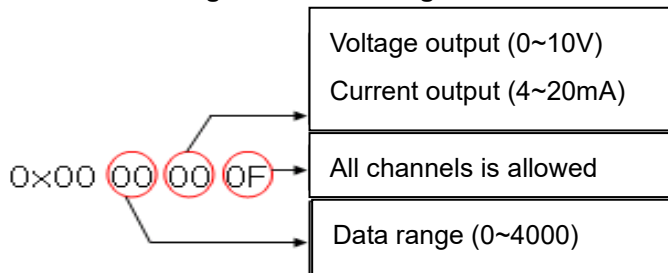

- 3) XBF-RD04A: all channels (Enable), Temp. unit (centigrade), input sensor type (PT100)

< Parameter setting value's meaning >

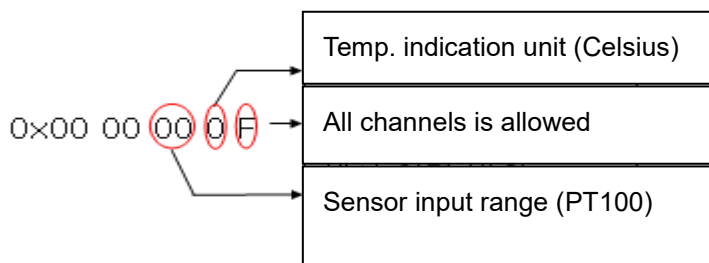

A.4 How to set an expansion type analog module parameter (XPL-BSSA)

A.4.1 Configuration of analog IO module parameter

Analog I/O module parameter of XPL-BSSA is as follows.

Module type	Parameter setting value (Decimal)	Contents		
		Analog I/O value	Digital I/O value	Remark
XBF-AD04A	0	0~10V	0~4,000	Initial value
	1	0~20mA	0~4,000	
	2	4~20mA	0~4,000	
	3	0~10V	-2,000~2,000	
	4	0~20mA	-2,000~2,000	
	5	4~20mA	-2,000~2,000	
	6	0~10V	0~1,000	
	7	0~20mA	0~1,000	
	8	4~20mA	0~1,000	
XBF-DV04A	0	0~10V	0~4,000	Initial value
	1	0~10V	-2,000~2,000	
	2	0~10V	0~1,000	
XBF-DC04A	0	4~20mA	0 ~ 4,000	Initial value
	1	0~20mA	0 ~ 4,000	
	2	4~20mA	0 ~ 1,000	
	3	0~20mA	0 ~ 1,000	
XBF-RD04A	0	pt100	Celsius	Initial value
	1	jpt100	Celsius	
	2	pt100	Fahrenheit	
	3	jpt100	Fahrenheit	
XBF-TC04S	0	K	Celsius	Initial value
	1	J		
	2	T		
	3	R		
	4	K	Fahrenheit	
	5	J		
	6	T		
	7	R		
XBF-AH04A, XBF-AD08A	0	1~5V	0~4,000	Initial value
	1		-2,000~2,000	
	2		Precise value	
	3		0~1000	
	4	0~5V	0~4,000	
	5		-2,000~2,000	
	6		Precise value	
	7		0~1000	
	8	0~10V	0~4,000	
	9		-2,000~2,000	
	10		Precise value	
	11		0~1000	

Module type	Parameter setting value (Decimal)	Contents		
		Analog I/O value	Digital I/O value	Remark
XBF-AH04A, XBF-AD08A	12	4~20mA	0~4,000	
	13		-2,000~2,000	
	14		Precise value	
	15		0~1000	
	16	0~20mA	0~4,000	
	17		-2,000~2,000	
	18		Precise value	
	19		0~1000	
XBF-AD04C	0	4~20mA	0~16,000	Initial value
	1		-8,000~8,000	
	2		Precise value	
	3		0~10,000	
	4	0~20mA	0~16,000	
	5		-8,000~8,000	
	6		Precise value	
	7		0~10,000	
	8	1~5V	0~16,000	
	9		-8,000~8,000	
	10		Precise value	
	11		0~10,000	
	12	0~5V	0~16,000	
	13		-8,000~8,000	
	14		Precise value	
	15		0~10,000	
	16	0~10V	0~16,000	
	17		-8,000~8,000	
	18		Precise value	
	19		0~10,000	
	20	-10~10V	0~16,000	
	21		-8,000~8,000	
	22		Precise value	
23	0~10,000			
XBF-DV04C	0	1~5V	0~16,000	Initial value
	1		-8,000~8,000	
	2		Precise value	
	3		0~10,000	
	4	0~5V	0~16,000	
	5		-8,000~8,000	
	6		Precise value	
	7		0~10,000	
	8	0~10V	0~16,000	
	9		-8,000~8,000	
	10		Precise value	
	11		0~10,000	
	12	-10~10V	0~16,000	
	13		-8,000~8,000	
	14		Precise value	
15	0~10,000			

Module type	Parameter setting value (Decimal)	Contents		
		Analog I/O value	Digital I/O value	Remark
XBF-DC04C	0	4~20mA	0~16,000	Initial value
	1		-8,000~8,000	
	2		Precise value	
	3		0~10,000	
	4	0~20mA	0~16,000	
	5		-8,000~8,000	
	6		Precise value	
	7		0~10,000	

A.4.2 How to set an analog parameter

How to set the analog parameter of XPL-BSSA is classified into two methods according to master module type. (Setting at Sycon and Setting at PROFICON). For G4L-PUCC and XGK-PMCC, PROFICON is used. And for other modules, Sycon is used for parameter setting

(1) Setting at Sycon

a) Double-click XPL-BSSA as below.



b) Click the “Parameter Data” at “Slave Configuration”

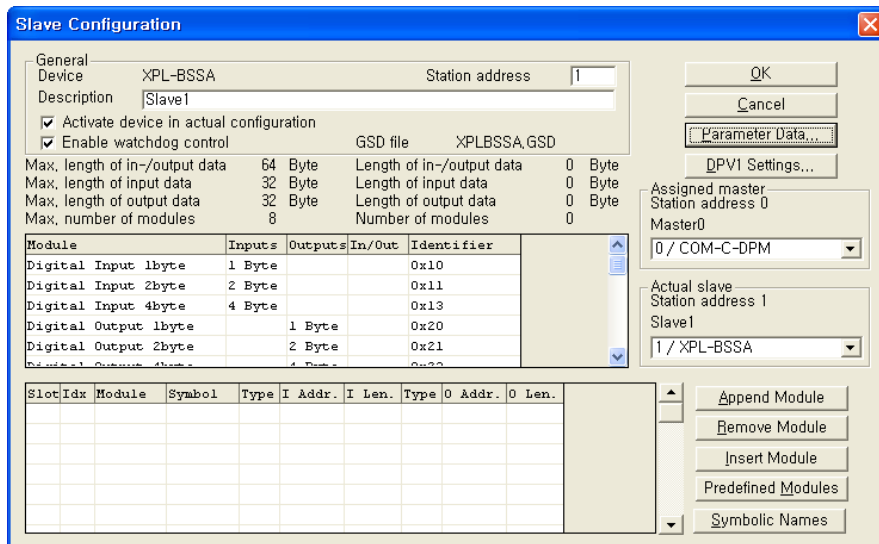

c) Set a parameter per each slot at Parameter Data. For parameter input, double-click the slot. At this time, parameter input value is decimal number.

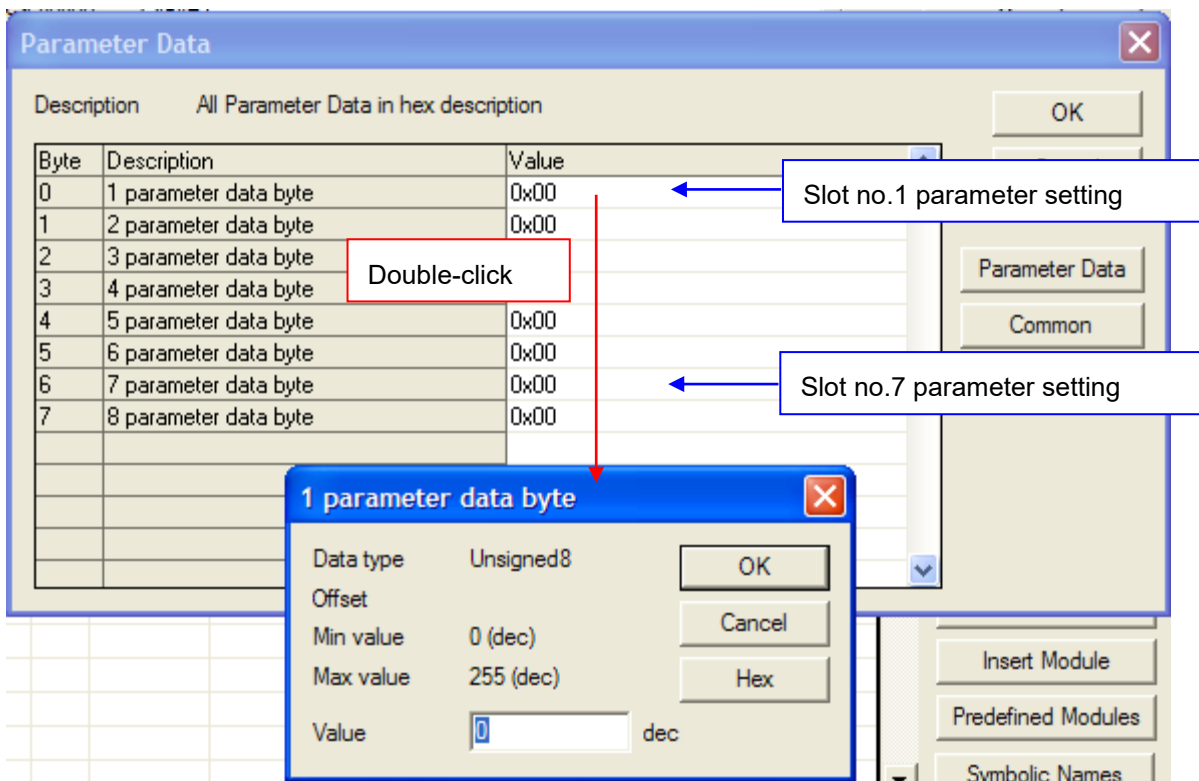

(2) Setting at nConfigurator

Click XPL-BSSA and then click “Configuration → Parameter Settings” in menu.

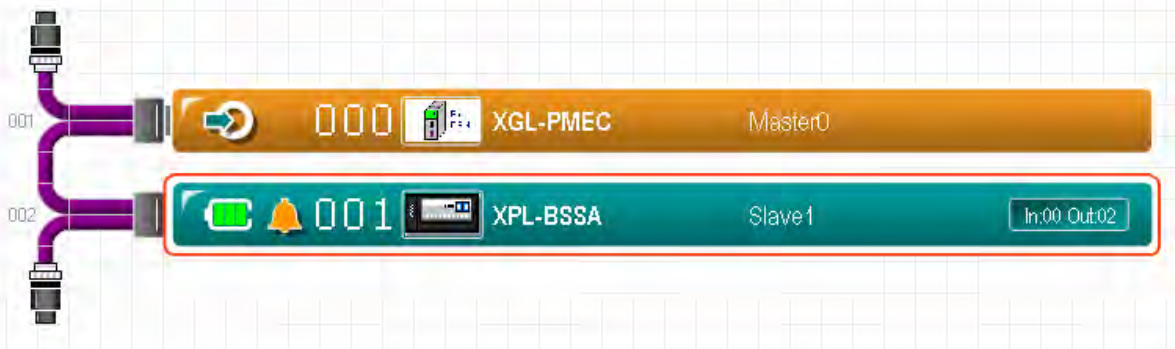

a) Click a “Parameter Data” at “Slave Configuration”

Set a parameter per each slot at Parameter Value. For parameter input, click Decimal and input a parameter. At this time, input value of each parameter is decimal number.

Slot	Module Name	Position	Byte	HexaDe	Decimal
1	(GENERAL)	000	0	0	0
2		001	0	0	0
3		002	0	0	0
4		003	0	0	0
5		004	0	0	0
6		005	0	0	0
7		006	0	0	0
8		007	0	0	0
9					0
10					
11					
12					
13					
14					
15					
16					
17					
18					
19					
20					
21					
22					

Position	Byte	Bit	Decimal	Description	Value
1	000	0	0		
2		1			
3		2			
4		3			
5		4			
6		5			
7		6			
8		7			
9	001	0	0	(Undefined)	(N/A)
10		1			
11		2			
12		3			
13		4			
14		5			
15		6			
16		7			
17	002	0	0	(Undefined)	(N/A)
18		1			
19		2			
20		3			
21		4			

Note

Caution in setting an analog parameter

- (1) Each parameter setting is necessary for each analog module.
- (2) If you don't set any parameter, module operates with initial parameter value.
- (3) The parameter is sent from master to slave.
 - ▶ Slave keeps previous value while cable is connected, regardless of power on/off.
 - ▶ If you restart the power while cable is not connected, module operated with initial value.

A.5 How to set an expansion type analog module parameter (XRL-BSSA)

A.5.1 Analog IO module parameter setting (Only for OS version 1.3 or higher)

* Parameter setting as below is provided for OS Version 1.3 or higher.

If you are using V1.2 or less, refer to A.5.2

(1) Analog Input Parameter Setting

1) XBF-AD04A

Memory address	Description	Bit								Configuration
		7	6	5	4	3	2	1	0	
0 : H ¹⁾	Configuration of channels to be used	-	-	-	-	Ch 3	Ch 2	Ch 1	Ch 0	Bit On (1): Operation Bit Off (0): Stop
0 : L ¹⁾	Designation of Input voltage/ current range	Ch3		Ch 2		Ch 1		Ch 0		00: 0 ~ 10V(4 ~ 20mA) 01: 0 ~ 20mA 10: 4 ~ 20mA
1 : H	Designation of output data range	Ch 3		Ch 2		Ch 1		Ch 0		00: 0 ~ 4000 01: -2000 ~ 2000 10: Precise value ²⁾ 11: 0 ~ 1000

2) XBF-AD08A

Memory address	Description	Bit								Configuration
		7	6	5	4	3	2	1	0	
0 : H	Configuration of channels to be used	Input 7	Input 6	Input 5	Input 4	Input 3	Input 2	Input 1	Input 0	Bit On (1): Operation Bit Off (0): Stop
0 : L	Designation of Input voltage/ current range	Ch 3		Ch 2		Ch 1		Ch 0		00 : 4 ~ 20 mA 01 : 0 ~ 20 mA 10 : 0 ~ 5 V 11 : 0 ~ 10 V
1 : H		Ch 7		Ch 6		Ch 5		Ch 4		
1 : L	Designation of output data range	Ch 6,7		Ch 4,5		Ch 2,3		Ch 0,1		00: 0 ~ 4000 01: -2000 ~ 2000 10: Precise value 11: 0 ~ 1000

3) XBF-AD04C

Memory address	Description	Bit								Configuration
		7	6	5	4	3	2	1	0	
0 :H	Configuration of channels to be used	-	-	-	-	Ch 3	Ch 2	Ch 1	Ch 0	Bit On (1): Operation Bit Off (0): Stop
0: L	Designation of Input voltage/ current range	Ch 1				Ch 0				0000: 4 ~ 20mA 0001: 0~20mA 0010: 1~5V 0100: 0~10V 0101: -10V~10V
1: H		Ch 3				Ch 2				
1: L	Designation of output data range	Ch 3		Ch 2		Ch 1		Ch 0		00: 0 ~ 16000 01: -8000 ~ 8000 10: Precise Value 11: 0 ~ 10000

Note

1) Meaning of memory address

H : High byte (In case that setting area of parameter value of PLC is 0x1234, H byte → 0x12)

▶ 0:H means that high byte of an word from memory address 0.

L: Low byte (In case that setting area of parameter value of PLC is 0x1234, L byte → 0x34)

▶ 1:L means that low byte of an word from memory address 1

2) Precise Value

▶ **Precise Value** = Range of input/output × 100

(Ex: Input range=0~5, Input or Output data range= Precise value

→ Data input range is 0~500)

3) Cautions in setting an analog parameter

(1) After setting a parameter, make sure you restart a power of XRL-BSSA module.
If the wrong device size does not operate.

(2) Parameter input value should be a decimal number.

(2) Analog Output parameter setting

1) XBF-DV04A

Memory address	Description	Bit								Configuration
		7	6	5	4	3	2	1	0	
0 : H	Configuration of channels to be used	-	-	-	-	Ch 3	Ch 2	Ch 1	Ch 0	Bit On (1): Operation Bit Off (0): Stop
0 : L	Designation of output range	Ch 3		Ch 2		Ch 1		Ch 0		00: 0 ~ 10V
1 : H	Designation of input data range	Ch 3		Ch 2		Ch 1		Ch 0		00: 0 ~ 4000 01: -2000 ~ 2000 10: Precise value 11: 0 ~ 1000

2) XBF-DV04C

Memory address	Description	Bit								Configuration
		7	6	5	4	3	2	1	0	
0 : H	Configuration of channels to be used	-	-	-	-	Ch 3	Ch 2	Ch 1	Ch 0	Bit On (1): Operation Bit Off (0): Stop
0 : L	Designation of output range	Ch 3		Ch 2		Ch 1		Ch 0		00: 1~5V 01: 0~5V 10: 0~10V 11: -10~10V
1 : H	Designation of input data range	Ch 3		Ch 2		Ch 1		Ch 0		00: 0 ~ 16000 01: -8000 ~ 8000 10: Precise value 11: 0 ~ 10000

3) XBF-DC04A

Memory address	Description	Bit								Configuration
		7	6	5	4	3	2	1	0	
0 : H	Configuration of channels to be used	-	-	-	-	Ch 3	Ch 2	Ch 1	Ch 0	Bit On (1): Operation Bit Off (0): Stop
0 : L	Designation of output range	Ch 3		Ch 2		Ch 1		Ch 0		00: 4 ~ 20mA 01: 0 ~ 20mA
1 : H	Designation of input data range	Ch 3		Ch 2		Ch 1		Ch 0		00: 0 ~ 4000 01: -2000 ~ 2000 10: Precise value 11: 0 ~ 1000

4) XBF-DC04C

Memory address	Description	Bit								Configuration
		7	6	5	4	3	2	1	0	
0 : H	Configuration of channels to be used	-	-	-	-	Ch 3	Ch 2	Ch 1	Ch 0	Bit On (1): Operation Bit Off (0): Stop
0 : L	Designation of output range	Ch 3		Ch 2		Ch 1		Ch 0		00: 4~20mA 01: 0~20mA
1 : H	Designation of input data range	Ch 3		Ch 2		Ch 1		Ch 0		00: 0 ~ 16000 01: -8000 ~ 8000 10: Precise value 11: 0 ~ 10000

(3) Thermocouple Input Parameter Setting (XBF-TC04S)

Memory address	Description	Bit								Configuration
		7	6	5	4	3	2	1	0	
0 : H	Configuration of channels to be used	-	-	-	-	Ch 3	Ch 2	Ch 1	Ch 0	Bit On (1): Operation Bit Off (0): Stop
0 : L	Configuration of output type	Ch 3		Ch 2		Ch 1		Ch 0		00 : K 01 : J 10 : T 11 : R
1 : H	Designation of input data range	-	-	-	-	Ch 3	Ch 2	Ch 1	Ch 0	0: Centigrade 1: Fahrenheit

(4) Resistance temperature detector Input Parameter Setting (XBF-RD04A)

Memory address	Description	Bit								Configuration
		7	6	5	4	3	2	1	0	
0 : H	Configuration of channels to be used	-	-	-	-	Ch 3	Ch 2	Ch 1	Ch 0	Bit On (1): Operation Bit Off (0): Stop
0 : L	Configuration of output type	Ch 3		Ch 2		Ch 1		Ch 0		00: PT100 01: JPT100
1 : H	Designation of input data range	-	-	-	-	Ch 3	Ch 2	Ch 1	Ch 0	0: Centigrade 1: Fahrenheit

(5) Analog I/O Combined Module (XBF-AH04A)

Memory address	Description	Bit								Configuration
		7	6	5	4	3	2	1	0	
0 : H	Configuration of channels to be used	-	-	-	-	Output Ch1	Output Ch0	Input Ch1	Input Ch0	Bit On (1): Operation Bit Off (0): Stop
0 : L	Designation of Input/ Output voltage/ current range	Output Ch1		Output Ch0		Input Ch1		Input Ch0		00 : 4 ~ 20 mA 01 : 0 ~ 20 mA 10 : 0 ~ 5 V 11 : 0 ~ 10 V
1 : H	Designation of input/ output data range	Output Ch1		Output Ch0		Input Ch1		Input Ch0		00: 0 ~ 4000 01: -2000 ~ 2000 10: Precise value 11: 0 ~ 1000

Note

Cautions in setting an analog parameter

1. After setting a parameter, make sure you restart a power of XRL-BSSA module.

A.5.2 Analog IO module parameter setting (Only for OS version 1.2 or less)

* Parameter setting as below is provided for OS Version V1.2 or less.

If you are using 1.3 or higher, refer to A.5.1

(1) Analog IO module parameter

Module type	Parameter setting value (Decimal)	Contents		
		Analog I/O value	Digital I/O value	Remark
XBF-AD04A	0	0~10V	0~4,000	Initial value
	1	0~20mA	0~4,000	
	2	4~20mA	0~4,000	
	3	0~10V	-2,000~2,000	
	4	0~20mA	-2,000~2,000	
	5	4~20mA	-2,000~2,000	
	6	0~10V	0~1,000	
	7	0~20mA	0~1,000	
	8	4~20mA	0~1,000	
XBF-DV04A	0	0~10V	0~4,000	Initial value
	1	0~10V	-2,000~2,000	
	2	0~10V	0~1,000	
XBF-DC04A	0	4~20mA	0 ~ 4,000	Initial value
	1	0~20mA	0 ~ 4,000	
	2	4~20mA	0 ~ 1,000	
	3	0~20mA	0 ~ 1,000	
XBF-RD04A	0	pt100	Celsius	Initial value
	1	jpt100	Celsius	
	2	pt100	Fahrenheit	
	3	jpt100	Fahrenheit	
XBF-TC04S	0	K	Celsius	Initial value
	1	J		
	2	T		
	3	R		
	4	K	Fahrenheit	
	5	J		
	6	T		
	7	R		
XBF-AH04A, XBF-AD08A	0	1~5V	0~4,000	Initial value
	1		-2,000~2,000	
	2		Precise value	
	3		0~1000	
	4	0~5V	0~4,000	
	5		-2,000~2,000	
	6		Precise value	
	7		0~1000	
	8	0~10V	0~4,000	
	9		-2,000~2,000	
	10		Precise value	
	11		0~1000	

Module type	Parameter setting value (Decimal)	Contents		
		Analog I/O value	Digital I/O value	Remark
XBF-AH04A, XBF-AD08A	12	4~20mA	0~4,000	
	13		-2,000~2,000	
	14		정규값	
	15		0~1000	
	16	0~20mA	0~4,000	
	17		-2,000~2,000	
	18		정규값	
	19		0~1000	

(2) How to set analog parameter

In case analog module is installed at XRL-BSSA, 2 byte parameter setting area other than I/O data area should be allocated. You can set analog I/O range by inputting a value at parameter setting area of figure below. At this time, parameter setting area is allocated as Read Area.

(1) Device area allocation of analog input module

▶ XBF-AD04A/RD04A/TC04A/AD08A

Size	2 byte	2 byte	2 byte	2 byte	2 byte
Area	Parameter setting area	CH 0 Input data	CH 1 Input data	...	CH N Input data

(2) Device area allocation of analog output module

▶ XBF-DV04A/DC04A

Size	2 byte	2 byte	2 byte	2 byte	2 byte
Area	CH 0 Output data	CH 1 Output data	...	CH N Output data	Parameter setting area

(3) Device area allocation of analog I/O module

▶ XBF-AH04A

Size	2 byte	2 byte	2 byte	2 byte	2 byte
Area	CH 0 Input data	CH 1 Input data	CH 0 Output data	CH 1 Output data	Parameter setting area

(4) Example when consisted of XRL-BSSA + XBE-TN32A + XBF-AD04A + XBF-DV04A+XBE-DC32A

▶ In case of XGI series

Module type	Mode	Station number	Read area	variable name	variable name comment	Sending data (Byte)	Save area	variable name	variable name comment	Receiving data (Byte)
XRL_BSSA	Send/Receive	1	%Mw0			16	%Mw200			12

▶ In case of XGK series

Module type	Mode	Station number	Read area	variable name	variable name comment	Sending data (Byte)	Save area	variable name	variable name comment	Receiving data (Byte)
XRL_BSSA	Send/Receive	1	M0000			16	M0200			12

▶ Meaning per each device area

CPU type	Item	Size (byte)	Device area	Contents
XGI	Read area	16 byte	MW0~MW1	XBE-TN32A's output value
			MW2	XBF-AD04A's parameter setting area
			MW3	XBF-DC04A's CH0 output data
			MW4	XBF-DC04A's CH1 output data
			MW5	XBF-DC04A's CH2 output data
			MW6	XBF-DC04A's CH3 output data
			MW7	XBF-DC04A's parameter setting area
	Save area	12 byte	MW200	XBF-AD04A's CH0 input value save area
			MW201	XBF-AD04A's CH1 input value save area
			MW202	XBF-AD04A's CH2 input value save area
MW203			XBF-AD04A's CH3 input value save area	
MW204~MW205			XBE-DC32A's input value save area	
XGK	Read area	16 byte	M0~M1	XBE-TN32A's output value
			M2	XBF-AD04A's parameter setting area
			M3	XBF-DC04A's CH0 output data
			M4	XBF-DC04A's CH1 output data
			M5	XBF-DC04A's CH2 output data
			M6	XBF-DC04A's CH3 output data
			M7	XBF-DC04A's parameter setting area
	Save area	12 byte	M200	XBF-AD04A's CH0 input value save area
			M201	XBF-AD04A's CH1 input value save area
			M202	XBF-AD04A's CH2 input value save area
M203			XBF-AD04A's CH3 input value save area	
M204~M205			XBE-DC32A's input value save area	

Note**Cautions in setting an analog parameter**

1. After setting a parameter, make sure you restart a power of XRL-BSSA module.
2. Parameter input value should be a decimal number.

A.6 Expansion Analog Module Parameter Setting Method (XEL-BSSA)

A.6.1 Analog Expansion Module Parameter Setting Criteria

(1) Analog Input Parameter Setting

1) XBF-AD04A

Memory address	Description	Bit								Configuration
		7	6	5	4	3	2	1	0	
0 : H ¹⁾	Configuration of channels to be used	-	-	-	-	Ch 3	Ch 2	Ch 1	Ch 0	Bit On (1): Operation Bit Off (0): Stop
0 : L ¹⁾	Designation of Input voltage/ current range	Ch3		Ch 2		Ch 1		Ch 0		00: 0 ~ 10V(4 ~ 20mA) 01: 0 ~ 20mA 10: 4 ~ 20mA
1 : H	Designation of output data range	Ch 3		Ch 2		Ch 1		Ch 0		00: 0 ~ 4000 01: -2000 ~ 2000 10: Precise value ²⁾ 11: 0 ~ 1000

2) XBF-AD08A

Memory address	Description	Bit								Configuration
		7	6	5	4	3	2	1	0	
0 : H	Configuration of channels to be used	Input 7	Input 6	Input 5	Input 4	Input 3	Input 2	Input 1	Input 0	Bit On (1): Operation Bit Off (0): Stop
0 : L	Designation of Input voltage/ current range	Ch 3		Ch 2		Ch 1		Ch 0		00 : 4 ~ 20 mA 01 : 0 ~ 20 mA 10 : 0 ~ 5 V 11 : 0 ~ 10 V
1 : H		Ch 7		Ch 6		Ch 5		Ch 4		
1 : L	Designation of output data range	Ch 6,7		Ch 4,5		Ch 2,3		Ch 0,1		00: 0 ~ 4000 01: -2000 ~ 2000 10: Precise value 11: 0 ~ 1000

3) XBF-AD04C

Memory address	Description	Bit								Configuration
		7	6	5	4	3	2	1	0	
0 :H	Configuration of channels to be used	-	-	-	-	Ch 3	Ch 2	Ch 1	Ch 0	Bit On (1): Operation Bit Off (0): Stop
0: L	Designation of Input voltage/ current range	Ch 1				Ch 0				0000: 4 ~ 20mA 0001: 0~20mA 0010: 1~5V 0100: 0~10V 0101: -10V~10V
1: H		Ch 3				Ch 2				
1: L	Designation of output data range	Ch 3	Ch 2	Ch 1	Ch 0	00: 0 ~ 16000 01: -8000 ~ 8000 10: Precise Value 11: 0 ~ 10000				

Note

1) Meaning of memory address

H : High byte (In case that setting area of parameter value of PLC is 0x1234, H byte → 0x12)

▶ 0:H means that high byte of an word from memory address 0.

L: Low byte (In case that setting area of parameter value of PLC is 0x1234, L byte → 0x34)

▶ 1:L means that low byte of an word from memory address 1

2) Precise Value

▶ **Precise Value** = Range of input/output × 100

(Ex: Input range=0~5, Input or Output data range= Precise value

→ Data input range is 0~500)

(2) Analog Output parameter setting

1) XBF-DV04A

Memory address	Description	Bit								Configuration
		7	6	5	4	3	2	1	0	
0 : H	Configuration of channels to be used	-	-	-	-	Ch 3	Ch 2	Ch 1	Ch 0	Bit On (1): Operation Bit Off (0): Stop
0 : L	Designation of output range	Ch 3		Ch 2		Ch 1		Ch 0		00: 0 ~ 10V
1 : H	Designation of input data range	Ch 3		Ch 2		Ch 1		Ch 0		00: 0 ~ 4000 01: -2000 ~ 2000 10: Precise value 11: 0 ~ 1000

2) XBF-DV04C

Memory address	Description	Bit								Configuration
		7	6	5	4	3	2	1	0	
0 : H	Configuration of channels to be used	-	-	-	-	Ch 3	Ch 2	Ch 1	Ch 0	Bit On (1): Operation Bit Off (0): Stop
0 : L	Designation of output range	Ch 3		Ch 2		Ch 1		Ch 0		00: 1~5V 01: 0~5V 10: 0~10V 11: -10~10V
1 : H	Designation of input data range	Ch 3		Ch 2		Ch 1		Ch 0		00: 0 ~ 16000 01: -8000 ~ 8000 10: Precise value 11: 0 ~ 10000

3) XBF-DC04A

Memory address	Description	Bit								Configuration
		7	6	5	4	3	2	1	0	
0 : H	Configuration of channels to be used	-	-	-	-	Ch 3	Ch 2	Ch 1	Ch 0	Bit On (1): Operation Bit Off (0): Stop
0 : L	Designation of output range	Ch 3		Ch 2		Ch 1		Ch 0		00: 4 ~ 20mA 01: 0 ~ 20mA
1 : H	Designation of input data range	Ch 3		Ch 2		Ch 1		Ch 0		00: 0 ~ 4000 01: -2000 ~ 2000 10: Precise value 11: 0 ~ 1000

4) XBF-DC04C

Memory address	Description	Bit								Configuration
		7	6	5	4	3	2	1	0	
0 : H	Configuration of channels to be used	-	-	-	-	Ch 3	Ch 2	Ch 1	Ch 0	Bit On (1): Operation Bit Off (0): Stop
0 : L	Designation of output range	Ch 3		Ch 2		Ch 1		Ch 0		00: 4~20mA 01: 0~20mA
1 : H	Designation of input data range	Ch 3		Ch 2		Ch 1		Ch 0		00: 0 ~ 16000 01: -8000 ~ 8000 10: Precise value 11: 0 ~ 10000

(3) Thermocouple Input Parameter Setting (XBF-TC04S)

Memory address	Description	Bit								Configuration
		7	6	5	4	3	2	1	0	
0 : H	Configuration of channels to be used	-	-	-	-	Ch 3	Ch 2	Ch 1	Ch 0	Bit On (1): Operation Bit Off (0): Stop
0 : L	Configuration of output type	Ch 3		Ch 2		Ch 1		Ch 0		00 : K 01 : J 10 : T 11 : R
1 : H	Designation of input data range	-	-	-	-	Ch 3	Ch 2	Ch 1	Ch 0	0: Centigrade 1: Fahrenheit

(4) Resistance temperature detector Input Parameter Setting (XBF-RD04A)

Memory address	Description	Bit								Configuration
		7	6	5	4	3	2	1	0	
0 : H	Configuration of channels to be used	-	-	-	-	Ch 3	Ch 2	Ch 1	Ch 0	Bit On (1): Operation Bit Off (0): Stop
0 : L	Configuration of output type	Ch 3		Ch 2		Ch 1		Ch 0		00: PT100 01: JPT100
1 : H	Designation of input data range	-	-	-	-	Ch 3	Ch 2	Ch 1	Ch 0	0: Centigrade 1: Fahrenheit

(5) Digital I/O Parameter Setting

Memory address	Description	Bit								Configuration
		7	6	5	4	3	2	1	0	
0 : H	Input filter	-	-	-	-	Input filter				0000: 3ms 0001: 1 ms 0010: 5 ms 0011: 10 ms 0100: 20 ms 0101: 70 ms 0110 : 100 ms
0 : L	Maintaining output is allowed	Configuration of maintaining output								0x01 : Allow Others: Prohibit
1 : H	Configuration of maintaining output by channels	56~63	48~55	40~47	32~39	24~31	16~23	8~15	0~7	0 : Clear 1 : Maintaining

(6) Analog I/O Combined Module (XBF-AH04A)

Memory address	Description	Bit								Configuration
		7	6	5	4	3	2	1	0	
0 : H	Configuration of channels to be used	-	-	-	-	Output Ch1	Output Ch0	Input Ch1	Input Ch0	Bit On (1): Operation Bit Off (0): Stop
0 : L	Designation of Input/ Output voltage/ current range	Output Ch1		Output Ch0		Input Ch1		Input Ch0		00 : 4 ~ 20 mA 01 : 0 ~ 20 mA 10 : 0 ~ 5 V 11 : 0 ~ 10 V
1 : H	Designation of input/ output data range	Output Ch1		Output Ch0		Input Ch1		Input Ch0		00: 0 ~ 4000 01: -2000 ~ 2000 10: Precise value 11: 0 ~ 1000

A.7 Expansion Analog Module Parameter Setting Method (XEL-BSSB)

A.7.1 Analog Expansion Module Parameter Setting Criteria

(1) Analog Input Parameter Setting

1) XBF-AD04A

Memory address	Description	Bit								Configuration
		7	6	5	4	3	2	1	0	
0	Configuration of channels to be used	-	-	-	-	Ch 3	Ch 2	Ch 1	Ch 0	Bit On (1): Operation Bit Off (0): Stop
1	Designation of Input voltage/ current range	Ch3		Ch 2		Ch 1		Ch 0		00: 0 ~ 10V(4 ~ 20mA) 01: 0 ~ 20mA 10: 4 ~ 20mA
2	Designation of output data range	Ch 3		Ch 2		Ch 1		Ch 0		00: 0 ~ 4000 01: -2000 ~ 2000 10: Precise value 11: 0 ~ 1000

2) XBF-AD08A

Memory address	Description	Bit								Configuration
		7	6	5	4	3	2	1	0	
0	Configuration of channels to be used	Input 7	Input 6	Input 5	Input 4	Input 3	Input 2	Input 1	Input 0	Bit On (1): Operation Bit Off (0): Stop
1	Designation of Input voltage/ current range	Ch 3		Ch 2		Ch 1		Ch 0		00 : 4 ~ 20 mA 01 : 0 ~ 20 mA 10 : 0 ~ 5 V 11 : 0 ~ 10 V
2		Ch 7		Ch 6		Ch 5		Ch 4		
3	Designation of output data range	Ch 6,7		Ch 4,5		Ch 2,3		Ch 0,1		00: 0 ~ 4000 01: -2000 ~ 2000 10: Precise value 11: 0 ~ 1000

3) XBF-AD04C

Memory address	Description	Bit								Configuration
		7	6	5	4	3	2	1	0	
0	Configuration of channels to be used	-	-	-	-	Ch 3	Ch 2	Ch 1	Ch 0	Bit On (1): Operation Bit Off (0): Stop
1	Designation of Input voltage/ current range	Ch 1				Ch 0				0000: 4 ~ 20mA 0001: 0~20mA 0010: 1~5V 0100: 0~10V 0101: -10V~10V
2		Ch 3				Ch 2				
3	Designation of output data range	Ch 3		Ch 2		Ch 1		Ch 0		00: 0 ~ 16000 01: -8000 ~ 8000 10: Precise Value 11: 0 ~ 10000

(2) Analog Output parameter setting

1) XBF-DV04A

Memory address	Description	Bit								Configuration
		7	6	5	4	3	2	1	0	
0	Configuration of channels to be used	-	-	-	-	Ch 3	Ch 2	Ch 1	Ch 0	Bit On (1): Operation Bit Off (0): Stop
1	Designation of output range	Ch 3		Ch 2		Ch 1		Ch 0		00: 0 ~ 10V
2	Designation of input data range	Ch 3		Ch 2		Ch 1		Ch 0		00: 0 ~ 4000 01: -2000 ~ 2000 10: Precise value 11: 0 ~ 1000
3	Designation of output status	Ch 3		Ch 2		Ch 1		Ch 0		00: previous output 01: minimum output 10: median output 11: maximum output

2) XBF-DV04C

Memory address	Description	Bit								Configuration
		7	6	5	4	3	2	1	0	
0	Configuration of channels to be used	-	-	-	-	Ch 3	Ch 2	Ch 1	Ch 0	Bit On (1): Operation Bit Off (0): Stop
1	Designation of output range	Ch 3		Ch 2		Ch 1		Ch 0		00: 1~5V 01: 0~5V 10: 0~10V 11: -10~10V
2	Designation of input data range	Ch 3		Ch 2		Ch 1		Ch 0		00: 0 ~ 16000 01: -8000 ~ 8000 10: Precise value 11: 0 ~ 10000
3	Designation of output status	Ch 3		Ch 2		Ch 1		Ch 0		00: previous output 01: minimum output 10: median output 11: maximum output

3) XBF-DC04A

Memory address	Description	Bit								Configuration
		7	6	5	4	3	2	1	0	
0	Configuration of channels to be used	-	-	-	-	Ch 3	Ch 2	Ch 1	Ch 0	Bit On (1): Operation Bit Off (0): Stop
1	Designation of output range	Ch 3		Ch 2		Ch 1		Ch 0		00: 4 ~ 20mA 01: 0 ~ 20mA
2	Designation of input data range	Ch 3		Ch 2		Ch 1		Ch 0		00: 0 ~ 4000 01: -2000 ~ 2000 10: Precise value 11: 0 ~ 1000
3	Designation of output status	Ch 3		Ch 2		Ch 1		Ch 0		00: previous output 01: minimum output 10: median output 11: maximum output

4) XBF-DC04C

Memory address	Description	Bit								Configuration
		7	6	5	4	3	2	1	0	
0	Configuration of channels to be used	-	-	-	-	Ch 3	Ch 2	Ch 1	Ch 0	Bit On (1): Operation Bit Off (0): Stop
1	Designation of output range	Ch 3		Ch 2		Ch 1		Ch 0		00: 4~20mA 01: 0~20mA
2	Designation of input data range	Ch 3		Ch 2		Ch 1		Ch 0		00: 0 ~ 16000 01: -8000 ~ 8000 10: Precise value 11: 0 ~ 10000
3	Designation of output status	Ch 3		Ch 2		Ch 1		Ch 0		00: previous output 01: minimum output 10: median output 11: maximum output

(3) Thermocouple Input Parameter Setting (XBF-TC04S)

Memory address	Description	Bit								Configuration
		7	6	5	4	3	2	1	0	
0	Configuration of channels to be used	-	-	-	-	Ch 3	Ch 2	Ch 1	Ch 0	Bit On (1): Operation Bit Off (0): Stop
1	Configuration of output type	Ch 3		Ch 2		Ch 1		Ch 0		00 : K 01 : J 10 : T 11 : R
2	Designation of input data range	-	-	-	-	Ch 3	Ch 2	Ch 1	Ch 0	0: Centigrade 1: Fahrenheit

(4) Resistance temperature detector Input Parameter Setting (XBF-RD04A)

Memory address	Description	Bit								Configuration
		7	6	5	4	3	2	1	0	
0	Configuration of channels to be used	-	-	-	-	Ch 3	Ch 2	Ch 1	Ch 0	Bit On (1): Operation Bit Off (0): Stop
1	Configuration of output type	Ch 3		Ch 2		Ch 1		Ch 0		00: PT100 01: JPT100
2	Designation of input data range	-	-	-	-	Ch 3	Ch 2	Ch 1	Ch 0	0: Centigrade 1: Fahrenheit

(5) Digital I/O Parameter Setting

Memory address	Description	Bit								Configuration
		7	6	5	4	3	2	1	0	
0	Input filter	-	-	-	-	Input filter				0000: 3ms 0001: 1 ms 0010: 5 ms 0011: 10 ms 0100: 20 ms 0101: 70 ms 0110 : 100 ms
1	Maintaining output is allowed	Configuration of maintaining output								0x01 : Allow Others: Prohibit
2	Configuration of maintaining output by channels	56~63	48~55	40~47	32~39	24~31	16~23	8~15	0~7	0 : Clear 1 : Maintaining

(6) Analog I/O Combined Module (XBF-AH04A)

Memory address	Description	Bit								Configuration
		7	6	5	4	3	2	1	0	
0	Configuration of channels to be used	-	-	-	-	Output Ch1	Output Ch0	Input Ch1	Input Ch0	Bit On (1): Operation Bit Off (0): Stop
1	Designation of Input/ Output voltage/ current range	Output Ch1		Output Ch0		Input Ch1		Input Ch0		00 : 4 ~ 20 mA 01 : 0 ~ 20 mA 10 : 0 ~ 5 V 11 : 0 ~ 10 V
2	Designation of input/ output data range	Output Ch1		Output Ch0		Input Ch1		Input Ch0		00: 0 ~ 4000 01: -2000 ~ 2000 10: Precise value 11: 0 ~ 1000
3	Configuration of output status by channels	Ch1				Ch0				0000: former value 0001: minimum value 0010: medium value 0011: maximum value

Warranty

1. Warranty Period

The product you purchased will be guaranteed for 18 months from the date of manufacturing.

2. Scope of Warranty

Any trouble or defect occurring for the above-mentioned period will be partially replaced or repaired. However, please note the following cases will be excluded from the scope of warranty.

- (1) Any trouble attributable to unreasonable condition, environment or handling otherwise specified in the manual,
- (2) Any trouble attributable to others' products,
- (3) If the product is modified or repaired in any other place not designated by the company,
- (4) Due to unintended purposes
- (5) Owing to the reasons unexpected at the level of the contemporary science and technology when delivered.
- (6) Not attributable to the company; for instance, natural disasters or fire

3. Since the above warranty is limited to PLC unit only, make sure to use the product considering the safety for system configuration or applications.

Environmental Policy

LS ELECTRIC Co., Ltd supports and observes the environmental policy as below.

Environmental Management

LS ELECTRIC considers the environmental preservation as the preferential management subject and every staff of LS ELECTRIC use the reasonable endeavors for the pleasurable environmental preservation of the earth.

About Disposal

LS ELECTRIC' PLC unit is designed to protect the environment. For the disposal, separate aluminum, iron and synthetic resin (cover) from the product as they are reusable.



www.lselectric.co.kr

LS ELECTRIC Co., Ltd.

■ Headquarter

LS-ro 127(Hogye-dong) Dongan-gu, Anyang-si, Gyeonggi-Do, 14119, Korea

■ Seoul Office

LS Yongsan Tower, 92, Hangang-daero, Yongsan-gu, Seoul, 04386, Korea
Tel: 82-2-2034-4033, 4888, 4703 Fax: 82-2-2034-4588
E-mail: automation@lselectric.co.kr

■ Factory

56, Samseong 4-gil, Mokcheon-eup, Dongnam-gu, Cheonan-si, Chungcheongnam-do, 31226, Korea

■ Overseas Subsidiaries

- **LS ELECTRIC Japan Co., Ltd. (Tokyo, Japan)**
Tel: 81-3-6268-8241 E-Mail: jschuna@lselectric.biz
- **LS ELECTRIC (Dalian) Co., Ltd. (Dalian, China)**
Tel: 86-411-8730-6495 E-Mail: jiheo@lselectric.com.cn
- **LS ELECTRIC (Wuxi) Co., Ltd. (Wuxi, China)**
Tel: 86-510-6851-6666 E-Mail: sblee@lselectric.co.kr
- **LS ELECTRIC Shanghai Office (China)**
Tel: 86-21-5237-9977 E-Mail: tsjun@lselectric.com.cn
- **LS ELECTRIC Vietnam Co., Ltd.**
Tel: 84-93-631-4099 E-Mail: jhchoi4@lselectric.biz (Hanoi)
Tel: 84-28-3823-7890 E-Mail: sjbaik@lselectric.biz (Hochiminh)
- **LS ELECTRIC Middle East FZE (Dubai, U.A.E.)**
Tel: 971-4-886-5360 E-Mail: salesme@lselectric.biz
- **LS ELECTRIC Europe B.V. (Hoofddorf, Netherlands)**
Tel: 31-20-654-1424 E-Mail: europartner@lselectric.biz
- **LS ELECTRIC America Inc. (Chicago, USA)**
Tel: 1-800-891-2941 E-Mail: sales.us@lselectricamerica.com

LS ELECTRIC  Technical Question or After-sales Service
Customer Center - Quick Responsive Service, Excellent technical support
TEL. 82-1644-5481 | www.lselectric.co.kr

Specifications in this instruction manual are subject to change without notice due to continuous products development and improvement.